

ANSI G7 STANDARD ROLLER CHAIN

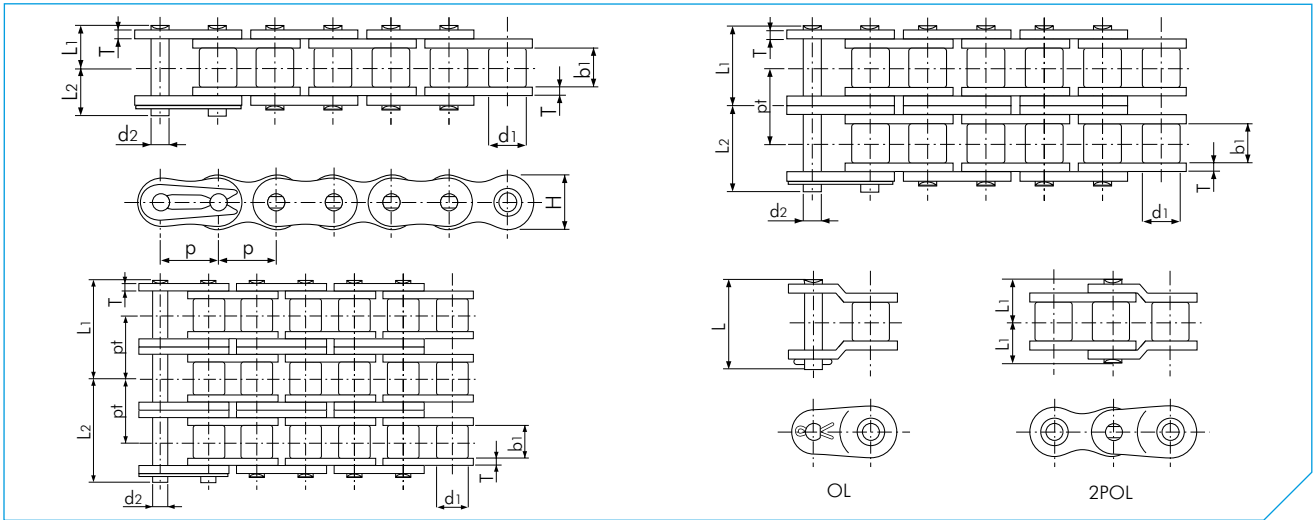

ANSI G7

Dimensions in mm

TSUBAKI Chain No.	Pitch p	Roller Diameter d1	Inner Width b1	Pin			Link Plate			Transverse Pitch pt	Min. Tensile Strength acc. to ANSI kN	Min. Tensile Strength acc. to Tsubaki kN	Approx. Mass kg/m
				Diameter d2	Length L1	Length L2	Length L	Thickness T	Height H (max)				
RS25-1	6.35 (1/4")	3.30	3.18	2.31	3.80	4.50	-	0.74	5.84	-	3.6	4.1	0.14
RS25-2					6.95	7.75	-			6.40	7.2	8.2	0.27
RS25-3					10.15	10.95	-			6.40	10.8	12.4	0.42
RS35-1	9.525 (3/8")	5.08	4.78	3.59	5.85	6.85	13.50	1.25	9.00	-	8.7	9.8	0.33
RS35-2					10.90	11.90	24.50			10.10	17.4	19.6	0.69
RS35-3					16.00	16.90	34.60			10.10	26.1	29.4	1.05
RS35-4	12.70 (1/2")	7.80	3.40	3.63	21.05	21.95	44.70	1.00	9.80	10.10	-	39.2	1.41
RS37-1					5.10	5.90	12.45			-	-	8.1	0.29
RS38-1					6.00	7.10	14.10			1.10	9.80	-	8.1
RS41-1	12.70 (1/2")	7.77	6.38	3.59	6.75	7.95	15.10	1.25	9.80	-	7.4	10.3	0.41
RS40-1	12.70 (1/2")	7.92	7.95	3.97	8.25	9.95	17.90	1.50	12.00	-	15.2	17.7	0.64
RS40-2					15.45	17.15	33.50			14.40	30.4	35.3	1.27
RS40-3					22.65	24.15	47.90			14.40	45.6	53.0	1.90
RS40-4					29.90	31.30	62.30			14.40	-	70.6	2.53
RS50-1	15.875 (5/8")	10.16	9.53	5.09	10.30	11.90	22.50	2.00	15.00	-	24.0	28.4	1.04
RS50-2					19.35	21.15	41.80			18.10	48.0	56.9	2.07
RS50-3					28.40	30.20	59.90			18.10	72.0	85.3	3.09
RS50-4					37.45	39.25	78.10			18.10	-	114.0	4.11
RS60-1	19.05 (3/4")	11.91	12.70	5.96	12.85	14.75	28.20	2.40	18.10	-	34.2	40.2	1.53
RS60-2					24.25	26.25	52.60			22.80	68.4	80.4	3.04
RS60-3					35.65	38.15	75.50			22.80	102.6	121.0	4.54
RS60-4					47.05	49.55	98.30			22.80	-	161.0	6.04
RS80-1	25.40 (1")	15.88	15.88	7.94	16.25	19.25	36.60	3.20	24.10	-	61.2	71.6	2.66
RS80-2					30.90	33.90	67.50			29.30	122.4	143.0	5.27
RS80-3					45.60	48.50	96.90			29.30	183.6	215.0	7.89
RS80-4					60.25	63.25	126.30			29.30	-	286.0	10.50
RS100-1	31.75 (1 1/4")	19.05	19.05	9.54	19.75	22.85	43.70	4.00	30.10	-	95.4	107.0	3.99
RS100-2					37.70	40.80	81.50			35.80	190.8	214.0	7.85
RS100-3					55.65	58.75	117.30			35.80	286.2	321.0	11.77
RS100-4					73.55	76.65	153.10			35.80	-	428.0	15.70
RS120-1	38.10 (1 1/2")	22.23	25.40	11.11	24.90	28.90	55.00	4.80	36.20	-	137.1	148.0	5.93
RS120-2					47.60	51.60	103.20			45.40	274.2	296.0	11.70
RS120-3					70.40	74.40	148.60			45.40	411.3	444.0	17.53
RS120-4					93.10	97.10	194.00			45.40	-	592.0	23.36
RS140-1	44.45 (1 3/4")	25.40	25.40	12.71	26.90	31.70	59.50	5.60	42.20	-	185.9	193.0	7.49
RS140-2					51.35	56.15	112.30			48.90	371.8	386.0	14.83
RS140-3					75.85	80.75	161.30			48.90	557.7	580.0	22.20
RS160-1	50.80 (2")	28.58	31.75	14.29	31.85	36.85	70.20	6.40	48.20	-	244.6	255.0	10.10
RS160-2					61.15	66.15	132.20			58.50	489.2	510.0	20.04
RS160-3					90.45	95.45	190.70			58.50	733.8	765.0	30.02
RS180-1	57.15 (2 1/4")	35.71	35.72	17.46	35.65	42.45	80.60	7.15	54.20	-	308.2	336.0	13.45
RS180-2					68.75	75.35	151.10			65.80	616.4	673.0	26.52
RS180-3					101.70	108.50	216.90			65.80	924.6	1010.0	38.22
RS200-1	63.50 (2 1/2")	39.68	38.10	19.85	39.00	44.80	87.30	8.00	60.30	-	381.7	427.0	16.49
RS200-2					74.85	80.65	161.20			71.60	763.4	853.0	32.63
RS200-3					110.75	116.45	233.00			71.60	1145.1	1280.0	49.02
RS240-1	76.20 (3")	47.63	47.63	23.81	47.90	55.50	106.70	9.50	72.40	-	550.4	623.0	24.50
RS240-2					91.90	99.40	198.40			87.80	1100.8	1250.0	48.10

Note:

- RS25 - RS35 are rollerless chain (only bush). The figure shown is the bush diameter.
- Connecting links are clip type for sizes up to RS60, and cotter type for sizes RS80 to RS200. RS240 connecting links are spring pin type.
- When a single pitch offset link is used, please calculate a 35% reduction of the fatigue strength.

ANSI HEAVY DUTY ROLLER CHAIN

The superior performance of TSUBAKI Heavy Duty chains is the result of a comprehensive quality control network that begins with selection of the world's finest steel materials. It continues with inspection and analysis of quality and performance in 20 different work areas. At TSUBAKI quality control is not just a one time check; it is a total dedication. It is your assurance of long lasting and dependable performance.

TSUBAKI offers Heavy Duty chains for applications that exceed the capabilities of TSUBAKI ANSI G7 standard roller chain. Heavy Duty chain should be considered in the following situations:

1. Harsh environments where the chain will be subjected to heavy impact.
2. Compact drives for equipment or machines that must work in tight spaces.
3. When higher transmission power, allowable load or tensile strength is required.
4. When a lower rate of elastic elongation is required.

H Series

H Series chain differs only from the ANSI G7 Series chain in the thickness of the link plates. The link plates have the same thickness as the link plates of the next larger pitch size in ANSI G7 Series. The increased thickness of the link plates provides a 10% greater capacity for absorbing shock loads. In short, H Series chains are especially suitable for situations where the load is heavy and operating speed is low (up to 50 m/min) or where operating conditions are severe.

HT Series

HT Series chain provides a (10% to 20%) higher Tensile Strength than ANSI G7 Series chain by using through-hardened pins and link plates of the next larger pitch size in ANSI G7 series. HT Series chain also provides a higher shock load resistance and is best suited for low operating speeds - up to 50 m/min. Dimensions of the chain are identical to the H Series chain.

SUPER Series

The dimensions of these series are identical to those of ANSI G7 Series chain. The special design of the SUPER Series link plate delivers exceptional performance. The pitch holes are critically formed and ball drifted and the pins are through-hardened for greater shock resistance (25% to 30%). SUPER Series chains offer 10% higher tensile strength than the equivalent size ANSI G7 Series chain. SUPER Series chains can be used to replace the next larger pitch size of ANSI G7 Series, making them ideal for applications where chain space is limited. Best suited for low speed operating conditions - up to 50 m/min.

SUPER-H Series

The thickness of the SUPER-H Series link plates is the same as the next larger pitch size of SUPER Series chain. The pins are also through-hardened which provides a higher tensile strength and a higher shock load resistance than SUPER Series chain. The pitch holes are critically formed and ball drifted. SUPER-H Series chains can be used to replace the next larger size of ANSI standard chain, making them ideal for applications where space is limited. Best suited for low speed operating conditions - up to 50 m/min.

ULTRA SUPER Series

ULTRA SUPER Series offer longer wear life, greater shock load resistance (170%) and higher tensile strength (150%) than any other TSUBAKI roller chain. The pins are through-hardened and the pin holes are critically formed and ball drifted. The diameter of the pins has been increased. This chain is well suited for applications where there are space limitations. The heavy duty construction of the ULTRA SUPER Series chain allows it to replace chains up to two pitch sizes larger ANSI G7 Series chain. It is best suited for low speed operating conditions up to 50 m/min.

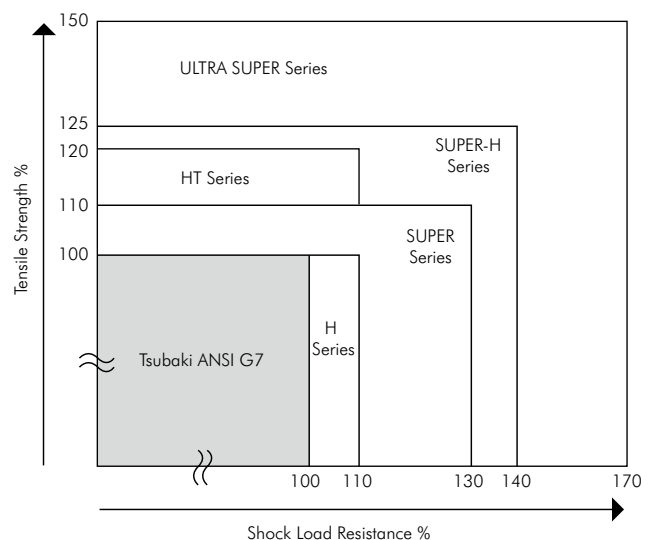
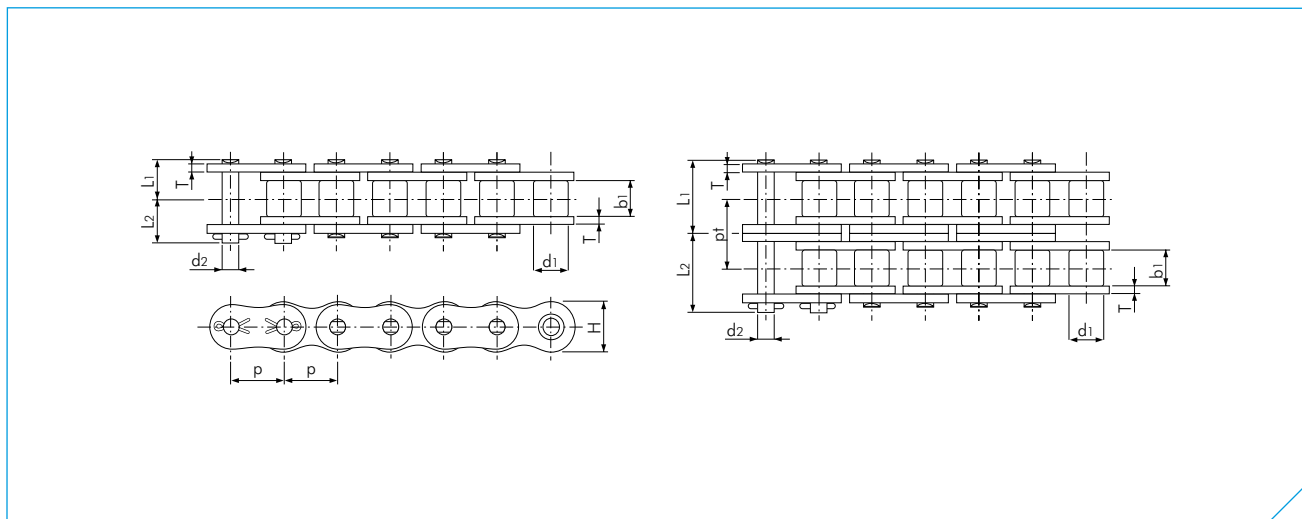

Fig. 16 Comparison of Tensile Strength / Shock Load Resistance

ANSI HEAVY DUTY ROLLER CHAIN



H Series

Dimensions in mm

TSUBAKI Chain No.	Pitch p	Roller Diameter d1	Inner Width b1	Pin			Link Plate		Transverse Pitch pt	Av. Tensile Strength acc. to Tsubaki kN	Approx. Mass kg/m
				Diameter d2	Length L1	Length L2	Thickness T	Height H (max)			
RS60-H-1	19.05 (3/4")	11.91	12.70	5.96	14.80	17.00	3.20	18.10	-	44.1	1.80
RS60-H-2					27.80	29.90			26.10	88.3	3.59
RS80-H-1	25.40 (1")	15.88	15.88	7.94	18.30	20.90	4.00	24.10	-	78.5	3.11
RS80-H-2					34.60	37.20			32.60	157.0	6.18
RS100-H-1	31.75 (1 1/4")	19.05	19.05	9.54	21.80	24.50	4.80	30.10	-	117.7	4.58
RS100-H-2					41.40	44.10			39.10	235.4	9.03
RS120-H-1	38.10 (1 1/2")	22.23	25.40	11.11	26.95	30.55	5.60	36.20	-	166.8	6.53
RS120-H-2					51.40	55.00			48.90	319.8	12.90
RS140-H-1	44.45 (1 3/4")	25.40	25.40	12.71	28.90	33.10	6.40	42.20	-	215.8	8.27
RS140-H-2					54.95	59.50			52.20	419.9	16.38
RS160-H-1	50.80 (2")	28.58	31.75	14.29	33.95	38.45	7.15	48.20	-	269.8	10.97
RS160-H-2					64.90	69.60			61.90	529.7	21.78
RS200-H-1	63.50 (2 1/2")	39.68	38.10	19.85	42.90	48.10	9.50	60.30	-	461.0	18.41

Note:

1. Standard ANSI sprockets can be used for single strand chain.
2. Multi strand chains need special sprockets, contact Tsubaki for more detailed information.
3. Sprockets with a low teeth number must have hardened teeth.
4. Steel grade of sprockets must be C45 or higher.

ANSI HEAVY DUTY ROLLER CHAIN

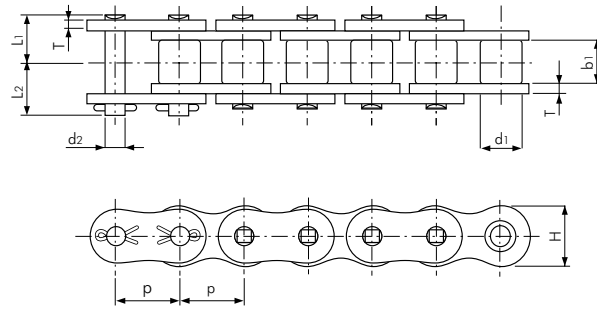

HT Series

Dimensions in mm

TSUBAKI Chain No.	Pitch p	Roller Diameter d1	Inner Width b1	Pin			Link Plate		Min. Tensile Strength acc. to Tsubaki kN	Av. Tensile Strength acc. to Tsubaki kN	Approx. Mass kg/m
				Diameter d2	Length L1	Length L2	Thickness T	Height H (max)			
RS60-HT-1	19.05 (3/4")	11.91	12.70	5.96	14.80	17.00	3.20	18.10	48.1	55.9	1.80
RS80-HT-1	25.40 (1")	15.88	15.88	7.94	18.30	20.90	4.00	24.10	81.4	93.2	3.11
RS100-HT-1	31.75 (1 1/4")	19.05	19.05	9.54	21.80	24.50	4.80	30.10	124.0	142.0	4.58
RS120-HT-1	38.10 (1 1/2")	22.23	25.40	11.11	26.95	30.55	5.60	36.20	167.0	191.0	6.53
RS140-HT-1	44.45 (1 3/4")	25.40	25.40	12.71	28.90	33.10	6.40	42.20	218.0	250.0	8.27
RS160-HT-1	50.80 (2")	28.58	31.75	14.29	33.95	38.45	7.15	48.20	278.0	319.0	10.97
RS200-HT-1	63.50 (2 1/2")	39.68	38.10	19.85	42.90	48.10	9.50	60.30	486.0	559.0	18.41
RS240-HT-1	76.20 (3")	47.63	47.63	23.81	54.80	62.30	12.70	72.40	768.0	883.0	29.13

Note:

1. Semi press-fit type connecting links are supplied.
2. Standard ANSI sprockets can be used for single strand chain.
3. Sprockets with a low teeth number must have hardened teeth.
4. Steel grade of sprockets must be C45 or higher.
5. Multi strand chains are available on request.
6. Pins are quad riveted.

ANSI HEAVY DUTY ROLLER CHAIN

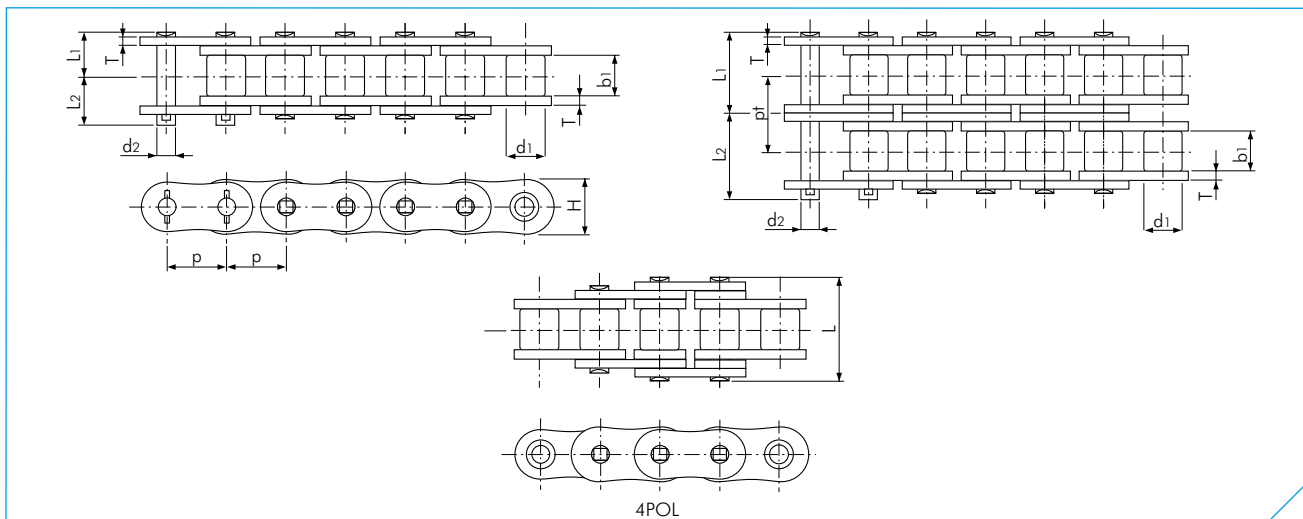

SUPER Series

Dimensions in mm

TSUBAKI Chain No.	Pitch p	Roller Diameter d1	Inner Width b1	Pin			Link Plate		Transverse Pitch pt	Min. Tensile Strength acc. to Tsubaki kN	Av. Tensile Strength acc. to Tsubaki kN	Approx. Mass kg/m	
				Diameter d2	Length L1	Length L2	Length L	Thickness T					Height H (max)
RS80-SUP-1	25.40 (1")	15.88	15.88	7.94	16.25	19.25	39.30	3.20	24.10	-	74.2	85.3	2.81
RS80-SUP-2					30.90	33.90	-			29.30	148.0	171.0	5.62
RS100-SUP-1	31.75 (1 1/4")	19.05	19.05	9.54	19.75	22.85	48.00	4.00	30.10	-	111.0	127.0	4.25
RS100-SUP-2					37.70	40.80	-			35.80	222.0	255.0	8.38
RS120-SUP-1	38.10 (1 1/2")	22.23	25.40	11.11	24.90	28.90	59.90	4.80	36.20	-	162.0	186.0	6.30
RS120-SUP-2					47.60	51.60	-			45.40	324.0	373.0	12.44
RS140-SUP-1	44.45 (1 3/4")	25.40	25.40	12.71	26.90	31.70	65.70	5.60	42.20	-	213.0	245.0	8.04
RS160-SUP-1	50.80 (2")	28.58	31.75	14.29	31.85	36.85	77.20	6.40	48.20	-	273.0	314.0	10.79
RS200-SUP-1	63.50 (2 1/2")	39.68	38.10	19.85	39.00	44.80	94.90	8.00	60.30	-	439.0	505.0	17.63
RS240-SUP-1	76.20 (3")	47.63	47.63	23.81	47.90	55.50	116.00	9.50	72.40	-	639.0	735.0	25.63

Note:

1. When a 4POL is used, please calculate a 10% reduction of the fatigue strength.
2. Standard ANSI sprockets can be used.
3. Pins are quad riveted.