

ČZ Řetězy - Strakonice, Czech Republic

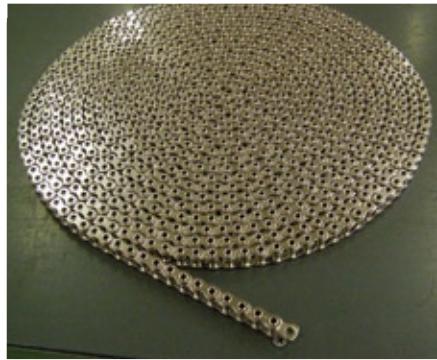

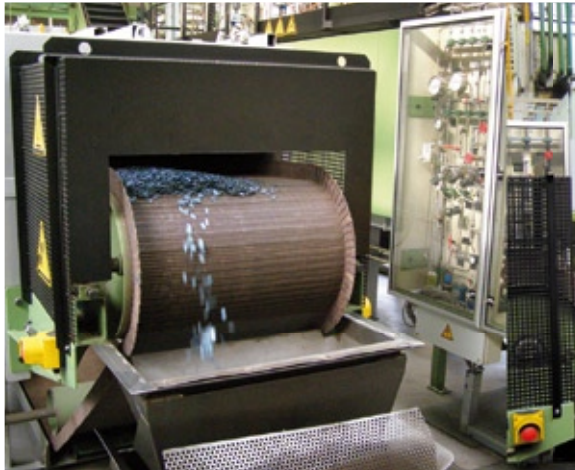

CONTENTS



ROLLER AND BUSH CHAINS

according to standards ISO, DIN, ASME, ČSN, ČZ



ROLLER CHAINS WITH ATTACHMENTS

according to standards ČSN, ČZ



ROLLER CHAINS WITH EXTENDED AND HOLLOW PINS

ČZ standard

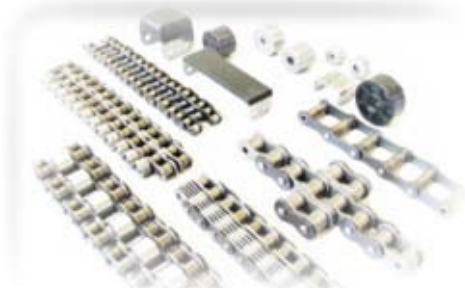

SPECIAL CHAINS

ČZ standard



LEAF CHAINS



PRODUCTION RANGE

ROLLER AND BUSH CHAINS

- roller chains according to ISO 606, DIN 8187, DIN 8188, ČSN 02 3311 and to the company standard
- bush chains according to ISO 1395, DIN 8164, ČSN 02 3321
- double pitch roller chains according to ISO 1275, DIN 818 and ČSN 02 3315

* CONVEYOR CHAINS

- with attachments according to ISO 606, DIN 8182 T2, ČSN 02 3312 and company standards
- with extended pins
- with hollow pins
- with rollers
- with side bow

* LEAF CHAINS

TECHNICAL ADVANTAGES OF ČZ CHAINS

- Research and development department
- Parts and chains design simulation software
- Manufacture of prototypes
- Simulation test bench
- Dynamic simulation
- Chain drive optimizing
- Chain assembling machines production know how
- Chain components precise mass production technology

INTRODUCTION

The production of chains in Strakonice under the registered trade marks ČZ, Favorit and Velo dates back to 1929. It arose as a secondary programme for the production of bicycles and motorcycles which was the principal manufacturing programme of the company called at that time „Česká zbrojovka“, Inc. The production of chains and their sortiment grew and since the year 1964 the chains are distributed all over the world. Today the company ČZ Řetězy, Ltd. produces and distributes roller and bush chains from pitch 8 mm to 25,4 mm and their modification including double-pitch modification.

Capitally, the company is a part of ČZ, Inc. which is the biggest engineering company in South Bohemia.

Chains are designed for bicycles, motorcycles, cars, engineering and farming machinery. Products are distributed through a sales network built inland and also abroad including sales service and technical support for users of our chains.

The quality of chains is systematically ensured by an established quality system and its standard was appreciated by confirming of the certificate according to standard ISO 9001, TS 16949 and standard 14001 by the certification authority TÜV Bayern.

The company ČZ Řetězy wants to meet its aim - satisfaction of customers - through its own know-how in development of chains and chain machinery and with the help of highly skilled workers and up-to-date technology.



Geometrical and dimensional exactness of each part of the chain is very important for the high durability and reliability. This is ensured in ČZ Řetězy by production technology based on quality management system. Geometrically and dimensionally quality processed parts must have high quality heat treatment, to ensure the good function of the chain. This requirement is achieved by using a hi-tech fully automatic process machine for steel heat treatment.



TECHNIQUE

Special machinery from leading international companies and special technologies for production of chains including assembly that were made here according to know-how of ČZ Řetězy, Ltd. are used for production of chains. Company laboratories are equipped with products of international companies and our own special testing machines. Production is constantly audited by internal and external auditors including competitors that our company co-operates with.

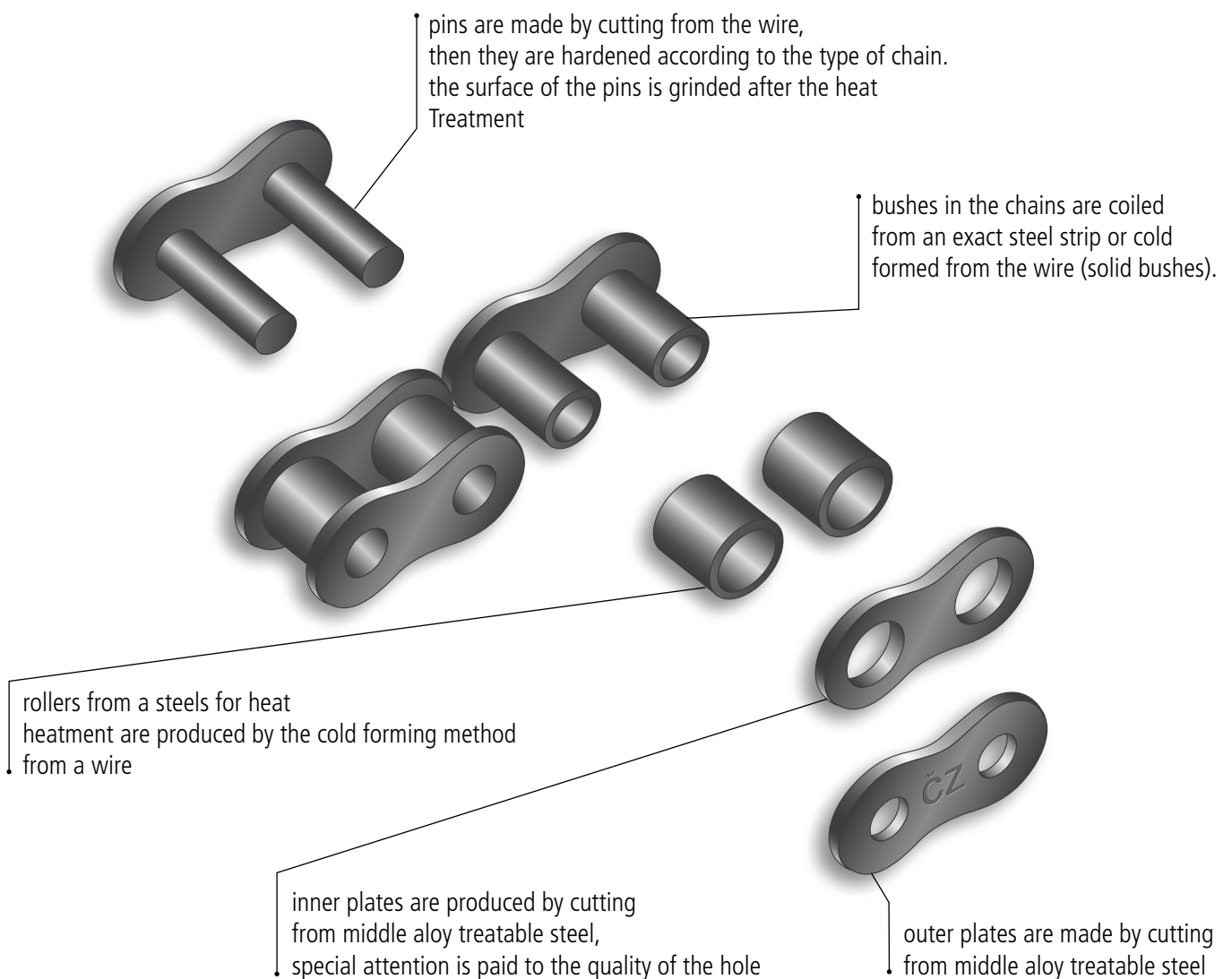

All products are supplied preserved or lubricated according to their aim and customer's wish. All surface treatments can be ordered.

ORDER EXAMPLES

It should be ordered 5 pieces of the chain 08B-1 in the length 109 links, in the beginning and in the end of the chain is inner link.

5 pcs. roller chain
08B-1 x 109 according to "mention the standard according to the catalogue list"

It should be ordered 5 pieces of the chain 08B-1 in the length 10 m, in the beginning and in the end of the chain is inner link and it should be with galvanized surface.

5 pcs. roller chain
08B-1 x 10 m according to "mention the standard according to the catalogue list"
galvanized surface on the outer plate - brass 5 mm

It should be ordered 5 pieces of the roller chain 08B-1 in the length 120 links, connected by the connecting link type E

5 pcs. roller chain
08B-1 x 120 E according to "mention the standard according to the catalogue list"

It should be ordered 100 pieces of the connecting link type E for the chain 08B-1

100 pcs. connecting links type E
for 08B-1 according to "mention the standard according to the catalogue list"

It should be ordered 5 pieces of the roller chain 08B-1 in the length 109 links, in the beginning of the chain is the offset link type L and in the end is connecting link type E

5 pcs. roller chain
08B-1 x 109 L E according to "mention the standard according to the catalogue list"

Shown chains order examples are valid for the standard and usual deliveries.

If you have any special requests (for example plating, different chain ends, preservation, packing.) specify them in the written form to the required type of the chain. It is necessary to clarify the concrete connecting elements with producer or supplier.

ROLLER AND BUSH CHAINS

According to standards ISO, DIN, ASME, ČSN, ČZ

Simplex roller chains - European design	9
according to standards ČSN 02 3311, DIN 8187 and ISO 606	
Duplex roller chains - European design	10
according to standards ČSN 02 3311, DIN 8187 and ISO 606	
Tripdex roller chains - European design	11
according to standards ČSN 02 3311, DIN 8187 and ISO 606	
Simplex roller chains - American design	12
according to standards ČSN 02 3311, DIN 8188, ISO 606 and ASME B29.1M	
Duplex roller chains - American design	13
according to standards ČSN 02 3311, DIN 8188, ISO 606 and ASME B29.1M	
Tripdex roller chains - American design	14
according to standards ČSN 02 3311, DIN 8188, ISO 606 and ASME B29.1M	
Roller chains	15
according to ČZ standard	
Simplex Stainless steel roller chains	16
Duplex Stainless steel roller chains	17
Tripdex Stainless steel roller chains	18
Double pitch chains	19
according to ČSN 02 3315, DIN 8181 and ISO 1275	
Bush chains	20
according to standards ČZ, ČSN 02 3321, DIN 8154, ISO 1395 and ASME B29.1M	
Connecting elements in general	21



Roller chains are the most used chains in almost all transmissions. Other kinds of chains are derived for their special usage. Exactly defined clearances appear among all moveable parts that ensure correct service and flexibility of the chain. This clearance is used like a lubricant pocket because the lubricant is necessary for a long durability and it contributes to absorption of operation noise and to absorption of oscillation at the transformed performance. Turning roller in the chain helps to easy rolling on the tooth profile of the wheel and together with this to slight wearing of the chain and the sprocket.

Double pitch roller chains correspond in design with roller chains including their main dimensions. Only the pitch of plates is doubled. Double pitch roller chains are mainly used in conveyors especially with extremely large axial distances. Furthermore, they are used in little loaded transmissions with a low circumferential speed and big sprockets. They have a half number of links for the same distance, that is why they also have lower wear, which is favourable at big axial distance.

Lower weight against standard roller chains is an indispensable fact.

Bush chains are derived in design from the roller chain but the roller is not used in this kind of chain.

When the chain is moving over wheels, the bush is gliding over the tooth profile (it is not rolling like the roller), which contributes to higher wear than at roller chains. Bush chains are produced because of their larger joint area (bush + pin). It is reached by bigger diameter of pin and bush at keeping the same main dimensions of the chain.

Stainless roller chains are chains that are made of stainless steel to be able to work in corrosion-aggressive environment and moreover usually without lubrication chemical, food-processing industry, etc. Dimensions correspond with roller chains, only their strength is lower see Tables.

All types of chains are available with electroplating of all parts or only with some parts, for example plates.

Electroplated chains with respect to corrosion build the stage between standard chains and stainless chains.

This type of chains is not recommended for higher dynamic stress.

Roller and bush chains with straight plates - indicated in the catalog by two stars **

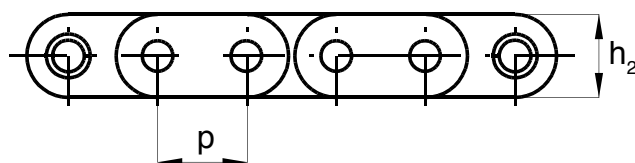

SIMPLEX ROLLER CHAINS

European design according to ČSN 02 3311, DIN 8187 and ISO 606

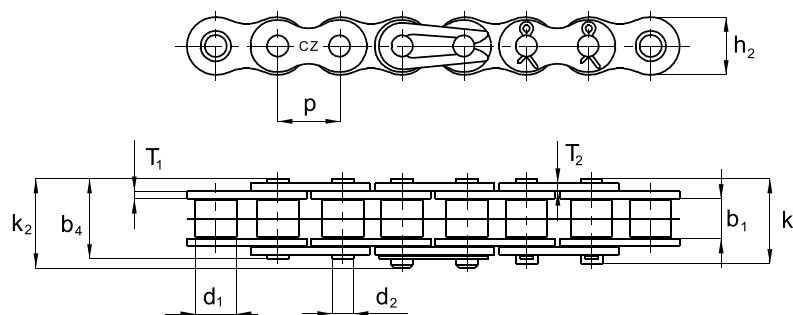

ISO DIN ČSN	PITCH p	INSIDE WIDTH b1 min.	ROLLER DIAMETER d1 max.	PIN DIAMETER d2 max.	PIN LENGHT b4 max.	CONNECT.		INNER PLATE WIDTH h2 max.	INNER PLATE THICKNESS T1	OUTER PLATE THICKNESS T2	BEARING AREA S	WEIGHT q	BREAKING LOAD FB min. N	CONNECTING ELEMENTS						
						CONNECT. PIN LENGHT k1 max.	CONNECT. PIN LENGHT k2 max.							B	A	E	S	L	LP	C
05 B-1	8,00	3,00	5,00	2,31	7,9		9,15	7,2	0,8	0,8	11	0,19	4620
06 B-1*	9,525	5,72	6,35	3,28	12,4		14	8,2	1,2	1	28	0,4	9345
081	12,7	3,3	7,75	3,66	9,2		10,8	9,9	1	1	21	0,3	8200
08 B-1**	12,7	7,75	8,51	4,45	16,4	19,4	18,25	11,8	1,6	1,4	50,3	0,7	18690
101	15,875	6,48	10,16	5,08	15,6		17,2	14,5	1,6	1,6	51,05	0,8	23310
10 B-1**	15,875	9,65	10,16	5,08	18,7	21,5	20,35	14,5	1,6	1,6	67,3	0,9	23310
12 B-1**	19,05	11,68	12,07	5,72	22,3	24,5	24	16,1	1,8	1,8	89,35	1,22	30345
16 B-1**	25,4	17,02	15,88	8,28	35,3	38,2	37,0	21	3,5	3	206,17	2,67	65000

*ONLY WITH STRAIGHT PLATES

**ALSO WITH STRAIGHT PLATES (THE WIDTH OF OUTER PLATE CORRESPONDS WITH THE WIDTH OF INNER PLATE - h2)

CONNECTING ELEMENTS

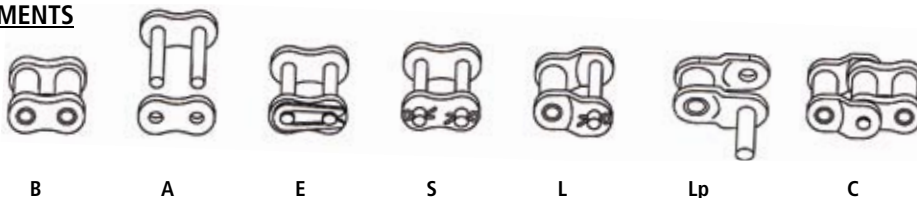

DUPLEX ROLLER CHAINS

European design according to ČSN 02 3311, DIN 8187 and ISO 606

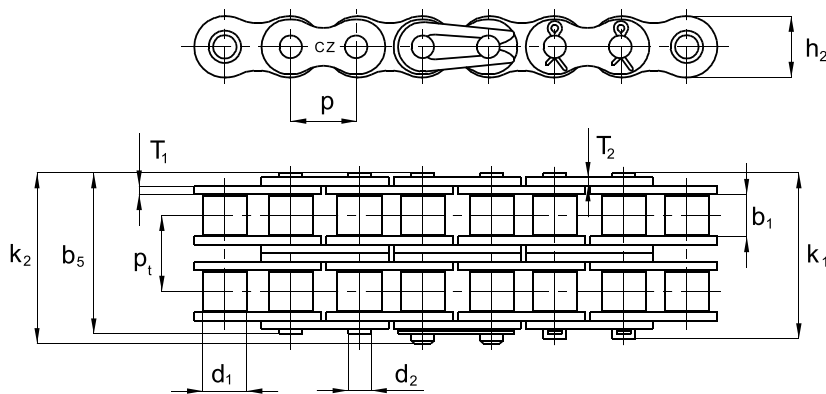

ISO DIN ČSN	PITCH	INSIDE WIDTH	ROLLER DIAMETER	PIN DIAMETER	PIN LENGTH	CONNECT. PIN LENGTH	CONNECT. PIN LENGTH	INNER PLATE WIDTH	INNER PLATE THICKNESS	OUTER PLATE THICKNESS	TRANS- VER. PITCH	BEARING AREA	WEIGHT	BREAKING LOAD	CONNECTING ELEMENTS					
															B	A	E	S	L	C
	p	b_1 min.	d_1 max.	d_2 max.	b_5 max.	k_1 max.	k_2 max.	h_2 max.	T_1	T_2	p_t	S	q	FB min.						
	mm	mm	mm	mm	mm	mm	mm	mm	mm	mm	mm	mm ²	kg/m	N						
05 B-2	8,0	3,00	5,00	2,31	13,55		14,75	7,20	0,80	0,80	5,64	22,00	0,34	8 000	•	•	•			
06 B-2*+	9,525	5,72	6,35	3,28	22,65		24,25	8,20	1,20	1,00	10,24	56,00	0,53	17 745	•	•	•		•	•
08 B-2**	12,7	7,75	8,51	4,45	30,45	33,30	32,15	11,80	1,60	1,40	13,92	100,60	1,37	32 655	•	•	•	•	•	•
10 B-2**	15,875	9,65	10,16	5,08	35,30	38,10	36,95	14,50	1,60	1,60	16,59	134,60	1,80	46 726	•	•	•	•	•	•
12 B-2**	19,05	11,68	12,07	5,72	41,75	44,00	43,80	16,10	1,80	1,80	19,46	178,70	2,43	60 690	•	•	•	•	•	•
16 B-2**	25,4	17,02	15,88	8,28	67,30	70,20	69,10	21,00	3,50	3,00	31,88	412,34	5,30	130 000	•	•	•	•	•	•

*ONLY WITH STRAIGHT PLATES

**ALSO WITH STRAIGHT PLATES (THE WIDTH OF OUTER PLATE CORRESPONDS WITH THE WIDTH OF INNER PLATE - h_2)

+ MIDDLE LINK PLATE HAS ONE SOLID PLATE

CONNECTING ELEMENTS

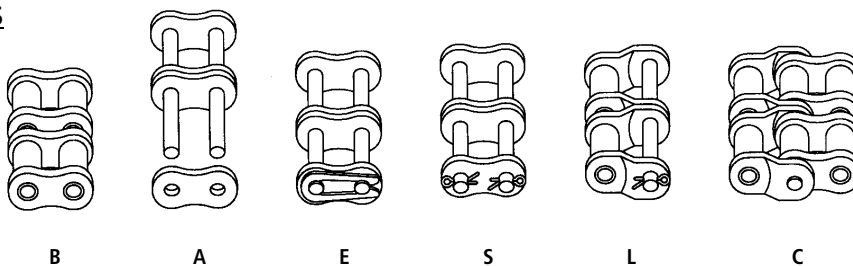

TRIPLEX ROLLER CHAINS

European design according to ČSN 02 3311, DIN 8187 and ISO 606

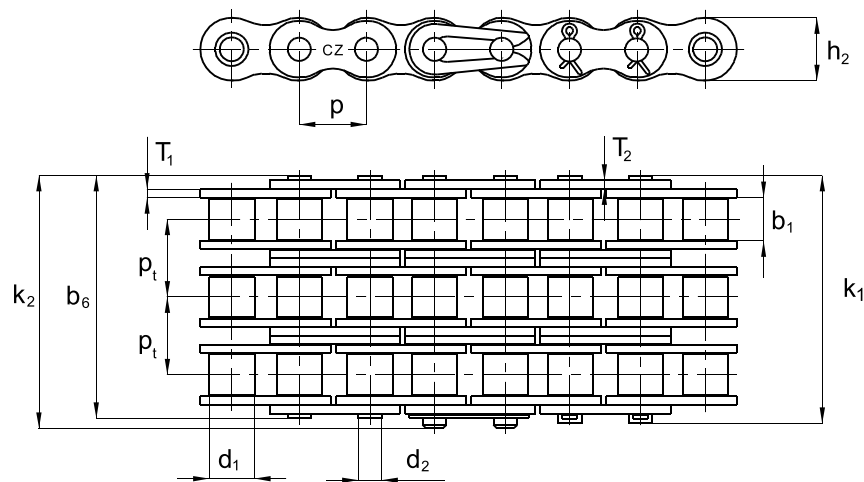

ISO DIN ČSN	PITCH	INSIDE WIDTH	ROLLER DIAMETER	PIN DIAMETER	PIN LENGHT	CONNECT.		INNER PLATE WIDTH	INNER PLATE THICKNESS	OUTER PLATE THICKNESS	TRANS- VER. PITCH	BEARING AREA	WEIGHT	BREAKING LOAD	CONNECTING ELEMENTS					
						PIN LENGHT.	PIN LENGHT.								B	A	E	S	L	C
	p	b1 min.	d1 max.	d2 max.	b6 max.	k1 max.	k2 max.	h2 max.	T1	T2	pt	S	q	FB min.						
	mm	mm	mm	mm	mm	mm	mm	mm	mm	mm	mm	mm ²	kg/m	N						
06 B-3*+	9,525	5,72	6,35	3,28	32,90		34,55	8,20	1,20	1,00	10,24	84,00	1,12	26 145	•	•	•	•	•	•
08 B-3**	12,7	7,75	8,51	4,45	44,25	47,20	46,20	11,80	1,60	1,40	13,92	150,80	2,04	46 725	•	•	•	•	•	•
10 B-3**	15,875	9,65	10,16	5,08	51,90	54,70	53,55	14,50	1,60	1,60	16,59	201,90	2,70	70 035	•	•	•	•	•	•
12 B-3**	19,05	11,68	12,07	5,72	61,25	63,50	63,40	16,10	1,80	1,80	19,46	268,05	3,62	91 035	•	•	•	•	•	•
16 B-3**	25,4	17,02	15,88	8,28	99,10	102,00	100,80	21,00	3,50	3,00	31,88	618,50	7,93	195 000	•	•	•	•	•	•

* ONLY WITH STRAIGHT PLATES

** ALSO WITH STRAIGHT PLATES (THE WIDTH OF OUTER PLATE CORRESPONDS WITH THE WIDTH OF INNER PLATE - h2)

+ MIDDLE LINK PLATE CONTAINS ONE SOLID PLATE

IN CASE OF REQUEST IS POSSIBLE TO PRODUCE ALSO 4, 5, 6, ROW CHAINS

CONNECTING ELEMENTS

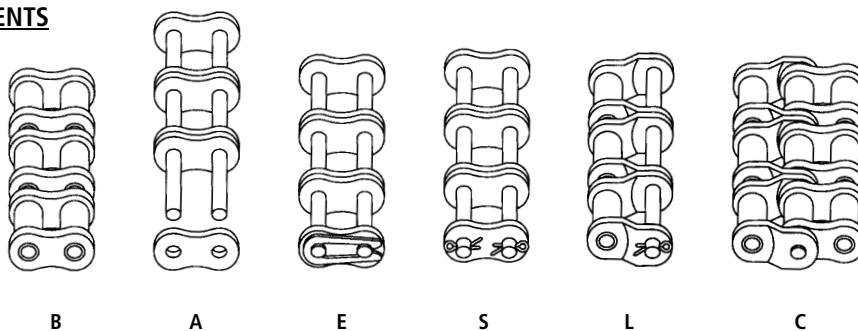

SIMPLEX ROLLER CHAINS

American design according to ČSN 02 3311,
DIN 8188, ISO 606 and ASME B 29.1M

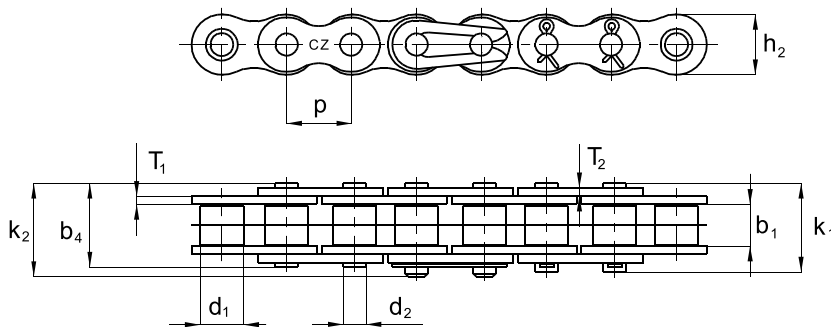

ISO DIN ČSN	TRADE MARK ČZ	PITCH p	INSIDE WIDTH b1 min.	ROLLER DIAMETER d1 max.	PIN DIAMETER d2 max.	PIN LENGHT b4 max.	CONNECT.		INNER PLATE WIDTH h2 max.	INNER PLATE THICKNESS T1	OUTER PLATE THICKNESS T2	BEARING AREA S	WEIGHT q	BREAKING LOAD FB min. N	CONNECTING ELEMENTS					
							PIN LENGHT k1 max.	PIN LENGHT k2 max.							B	A	E	S	L	C
08 A-1	ČZ 40	12,7	7,85	7,95	3,96	16,40	19,00	17,70	12,00	1,50	1,50	44,23	0,68	17 500	•	•	•	•	•	•
	08 A-H	12,7	7,85	7,95	3,96	18,20	21,80	19,50	12,00	2,00	2,00	47,52	0,75	20 000	•	•	•	•		
10 A-1	ČZ 50	15,875	9,53	10,16	5,08	20,10	22,90	21,70	14,50	2,00	2,00	70,10	0,82	27 200	•	•	•	•	•	•
	10 A-H	15,875	9,53	10,16	5,08	21,60	24,50	23,30	14,50	2,40	2,40	74,17	1,17	32 600	•	•	•	•		
12 A-1**	ČZ 60	19,05	12,70	11,91	5,94	25,40	28,30	27,00	17,70	2,40	2,40	105,40	1,58	32 655	•	•	•	•	•	•
	12 A-H	19,05	12,70	11,91	5,94	28,85	31,70	30,60	17,70	3,20	3,20	115,83	1,92	40 000	•	•	•	•		

** ALSO WITH STRAIGHT PLATES (THE WIDTH OF OUTER PLATE CORRESPONDS WITH THE WIDTH OF INNER PLATE - h2)

CONNECTING ELEMENTS

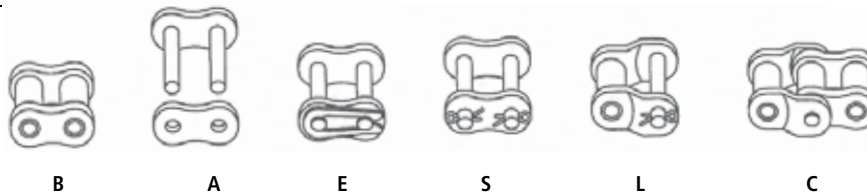

DUPLEX ROLLER CHAINS

American design according to ČSN 02 3311,
DIN 8188, ISO 606 and ASME B 29.1M

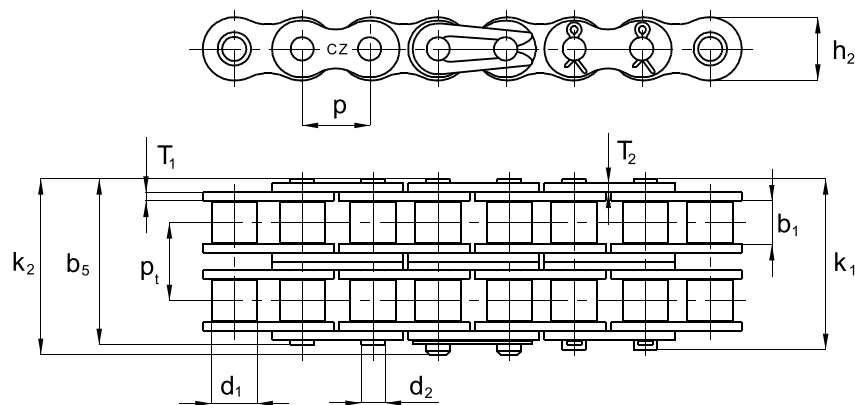

ISO DIN ČSN	TRADE MARK ČZ	PITCH p	INSIDE WIDTH b1 min.	ROLLER DIAMETER d1 max.	PIN DIAMETER d2 max.	PIN LENGTH b5 max.	CONNECT. PIN LENGTH k1 max.	CONNECT. PIN LENGTH k2 max.	INNER PLATE WIDTH h2 max.	INNER PLATE THICKNESS T1	OUTER PLATE THICKNESS T2	TRANS- VER. PITCH pt	BEARING AREA S	WEIGHT q	BREAKING LOAD FB min. N	CONNECTING ELEMENTS					
																B	A	E	S	L	C
08 A-2	ČZ 40	12,7	7,85	7,95	3,96	30,70	33,40	32,00	12,00	1,50	1,50	14,38	88,46	1,31	28 200	•	•	•	•	•	•
10 A-2	ČZ 50	15,875	9,53	10,16	5,08	38,20	39,00	39,85	14,50	2,00	2,00	18,11	140,20	2,06	54 400	•	•	•	•	•	•
12 A-2**	ČZ 60	19,05	12,70	11,91	5,94	48,20	51,20	49,80	17,70	2,40	2,40	22,78	210,80	3,15	65 415	•	•	•	•	•	•

**ALSO WITH STRAIGHT PLATES (THE WIDTH OF OUTER PLATE CORRESPONDS WITH THE WIDTH OF INNER PLATE - h2)

CONNECTING ELEMENTS

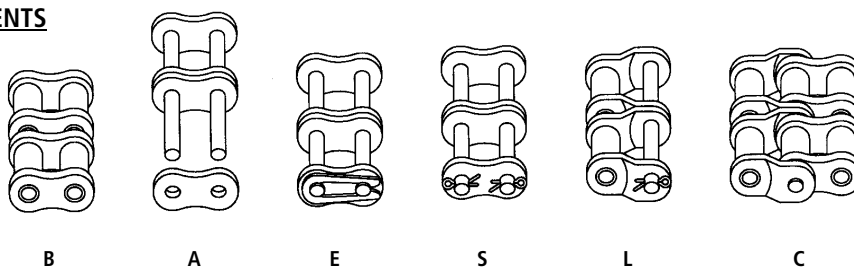

TRIPLEX ROLLER CHAINS

American design according to ČSN 02 3311,
DIN 8188, ISO 606 and ASME B 29.1M

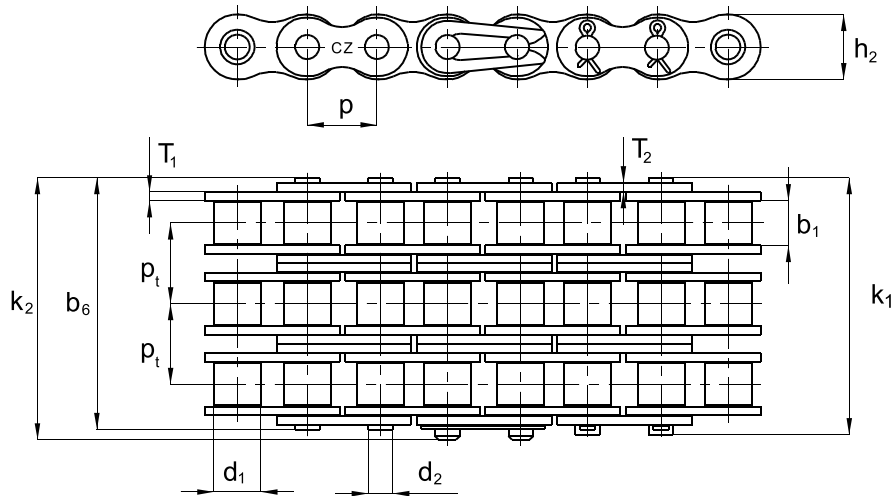

ISO ČSN DIN	TRADE MARK ČZ	PITCH p	INSIDE WIDTH b1 min.	ROLLER DIAMETER d1 max.	PIN DIAMETER d2 max.	PIN LENGHT b6 max.	CONNECT. PIN LENGHT k1 max.	CONNECT. PIN LENGHT k2 max.	INNER PLATE WIDTH h2 max.	INNER PLATE THICKNESS T1	OUTER PLATE THICKNESS T2	TRANS- VER. PITCH pt	BEARING AREA S	WEIGHT q	BREAKING LOAD FB min. N	CONNECTING ELEMENTS					
																B	A	E	S	L	C
08 A-3	ČZ 40	12,7	7,85	7,95	3,96	45,10	47,80	46,40	12,00	1,50	1,50	14,38	132,70	1,96	42 300	•	•	•	•	•	•
10 A-3	ČZ 50	15,875	9,53	10,16	5,08	56,30	57,00	57,90	14,50	2,00	2,00	18,11	210,30	2,00	81 600	•	•	•	•	•	•
12 A-3**	ČZ 60	19,05	12,70	11,91	5,94	71,60	74,50	73,40	17,70	2,40	2,40	22,78	316,30	4,53	98 070	•	•	•	•	•	•

** ALSO WITH STRAIGHT PLATES (THE WIDTH OF OUTER PLATE CORRESPONDS WITH THE WIDTH OF INNER PLATE - h2)
IN CASE OF REQUEST IS POSSIBLE TO PRODUCE ALSO 4, 5, 6, ROW CHAINS

CONNECTING ELEMENTS

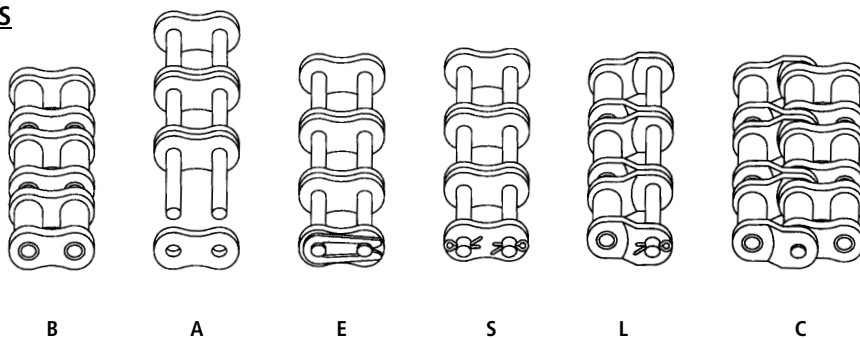

ROLLER CHAINS

According to ČZ Standard

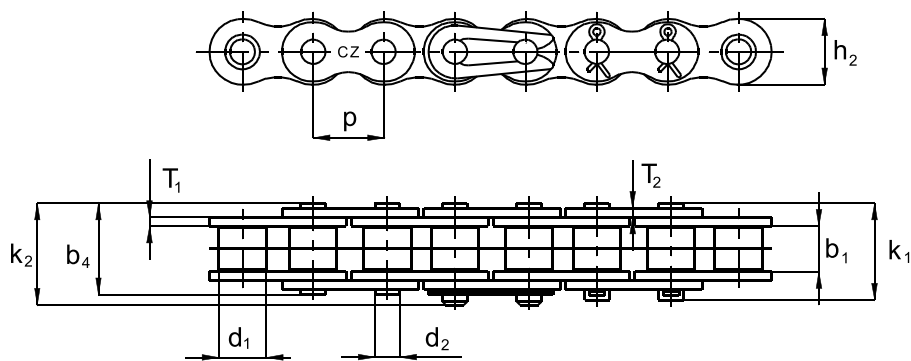

ISO ČSN	TRADE MARK ČZ	PITCH	INSIDE WIDTH	ROLLER DIAMETER	PIN DIAMETER	PIN LENGHT	CONNECT.		INNER PLATE WIDTH	INNER PLATE THICKNESS	OUTER PLATE THICKNESS	BEARING AREA	WEIGHT	BREAKING LOAD	CONNECTING ELEMENTS							
							PIN LENGHT	PIN LENGHT							B	A	E	S	L	LP	C	
		p	b1 min.	d1 max.	d2 max.	b4 max.	k1 max.	k2 max.	h2 max.	T1	T2	S	q	FB min.								
		mm	mm	mm	mm	mm	mm	mm	mm	mm	mm	mm ²	kg/m	N								
06 A	3/8"x3,9*	9,525	3,94	6,35	3,28	10,60		12,05	8,20	1,20	1,00	21,97	0,35	9 345	•	•	•					
	06 B STRONG*	9,525	5,72	6,35	3,28	13,35		14,70	8,20	1,50	1,20	29,25	0,72	14 300	•	•	•		•		•	
	1/2"x3/16" VELO	12,7	4,88	7,75	3,66	11,20		12,30	9,90	1,00	1,00	26,53	0,35	8 400	•	•	•		•	•	•	
	1/2"x3/16" V.T.	12,7	4,88	7,75	4,18	13,00		14,30	10,90	1,40	1,40	33,86	0,48	10 500	•	•	•		•		•	
	1/2"x3/16" MOFA	12,7	4,88	7,75	4,18	13,00		14,30	10,90	1,40	1,40	33,86	0,48	15 750	•	•	•		•		•	
086	1/2"x5,2	12,7	5,30	8,51	4,45	13,90		15,90	11,80	1,60	1,40	39,38	0,62	18 690	•	•	•		•		•	
	1/2"x1/4" MOFA	12,7	6,40	7,75	4,18	14,50		15,90	10,90	1,40	1,40	40,13	0,52	15 750	•	•	•		•		•	
	12 B STRONG**	19,05	11,68	12,07	6,10	24,50	26,85	26,20	17,70	2,40	2,40	101,87	1,51	36 000	•	•	•	•	•		•	
	1"x1/2"***	25,4	12,70	15,88	8,28	31,10		32,90	21,00	3,50	3,00	171,40	2,38	65 000	•	•	•		•		•	
	1"x43/64" R24*	25,4	17,02	15,88	8,28	35,30	38,20	37,00	24,00	3,50	3,00	206,17	3,30	74 000	•	•	•	•				

*ONLY WITH STRAIGHT PLATES

**ALSO WITH STRAIGHT PLATES (THE WIDTH OF OUTER PLATE CORRESPONDS WITH THE WIDTH OF INNER PLATE - h2)

CONNECTING ELEMENTS

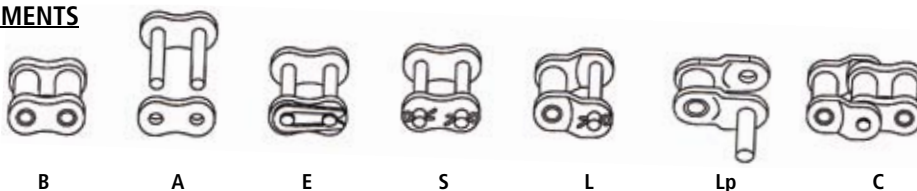

SIMPLEX STAINLESS STEEL ROLLER CHAINS

ČZ Standard

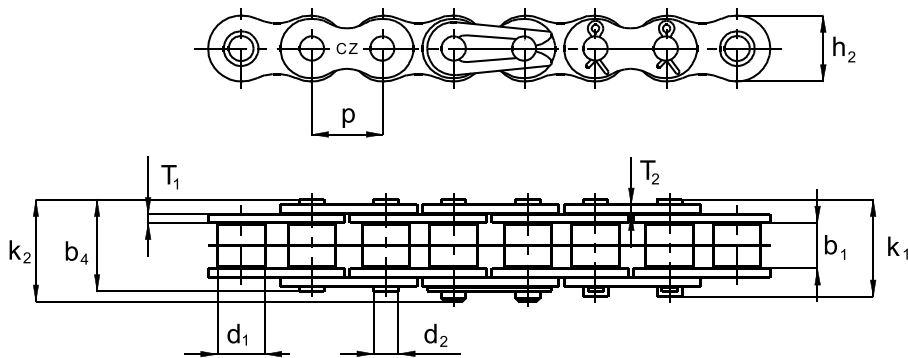

ISO DIN ČSN	PITCH	INSIDE WIDTH	ROLLER DIAMETER	PIN DIAMETER	PIN LENGTH	CONNECT. PIN LENGTH	CONNECT. PIN LENGTH	INNER PLATE WIDTH	INNER PLATE THICKNESS	OUTER PLATE THICKNESS	BEARING AREA	WEIGHT	BREAKING LOAD	CONNECTING ELEMENTS					
														B	A	E	S	L	C
	p	b1 min.	d1 max.	d2 max.	b4 max.	k1 max.	k2 max.	h2 max.	T1	T2	S	q	FB min.						
	mm	mm	mm	mm	mm	mm	mm	mm	mm	mm	mm ²	kg/m	N						
06 B-1*	9,525	5,72	6,35	3,28	12,40		14,00	8,20	1,20	1,00	28,00	0,40	5 350	•	•	•	•	•	•
08 B-1	12,7	7,75	8,51	4,45	16,40	19,40	18,25	11,80	1,60	1,40	50,30	0,70	12 000	•	•	•	•	•	•
10 B-1	15,875	9,65	10,16	5,08	18,70		20,35	14,50	1,60	1,60	67,30	0,90	14 200	•	•	•	•	•	•
12 B-1**	19,05	11,68	12,07	5,72	22,30	24,50	24,00	16,10	1,80	1,80	89,35	1,22	18 000	•	•	•	•	•	•
16 B-1**	25,4	17,02	15,88	8,28	35,30	38,20	37,00	21,00	3,50	3,00	206,17	2,67	41 000	•	•	•	•	•	•

* ONLY WITH STRAIGHT PLATES

** ALSO WITH STRAIGHT PLATES (THE WIDTH OF OUTER PLATE CORRESPONDS WITH THE WIDTH OF INNER PLATE - h2)

CONNECTING ELEMENTS

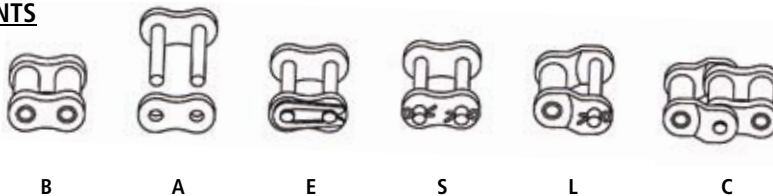

DUPLEX STAINLESS STEEL ROLLER CHAINS

According to ČZ Standard

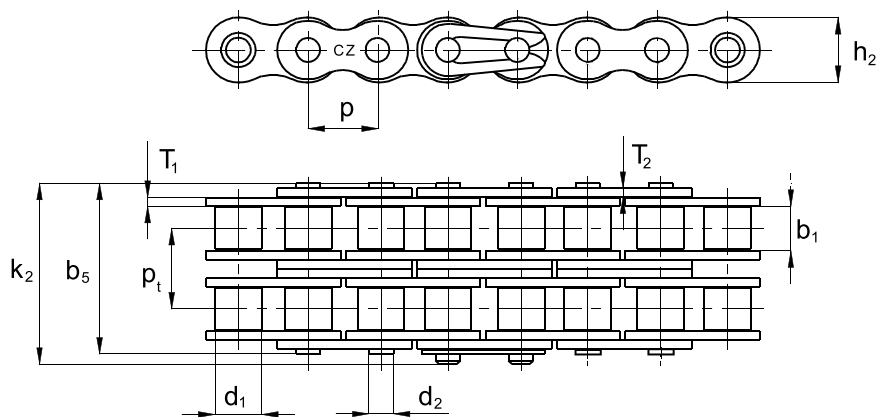

ISO DIN ČSN	PITCH	INSIDE WIDTH	ROLLER DIAMETER	PIN DIAMETER	PIN LENGHT	CONNECT. PIN LENGHT	INNER PLATE WIDTH	INNER PLATE THICKNESS	OUTER PLATE THICKNESS	TRANSVER. PITCH	BEARING AREA	WEIGHT	BREAKING LOAD	CONNECTING ELEMENTS			
														B	A	E	L
	p	b1 min.	d1 max.	d2 max.	b5 max.	k2 max.	h2 max.	T1	T2	pt	S	q	FB min.				
	mm	mm	mm	mm	mm	mm	mm	mm	mm	mm	mm ²	kg/m	N				
06 B-2*+	9,525	5,72	6,35	3,28	22,65	24,25	8,20	1,20	1,00	10,24	56,00	0,53	11 000	•	•	•	•
08 B-2	12,7	7,75	8,51	4,45	30,45	32,15	11,80	1,60	1,40	13,92	100,60	1,37	24 000	•	•	•	•
10 B-2	15,875	9,65	10,16	5,08	35,30	36,95	14,50	1,60	1,60	16,59	134,60	1,80	28 000	•	•	•	•
12 B-2**	19,05	11,68	12,07	5,72	41,75	43,80	16,10	1,80	1,80	19,46	178,70	2,42	36 000	•	•	•	•

* ONLY WITH STRAIGHT PLATES

** ALSO WITH STRAIGHT PLATES (THE WIDTH OF OUTER PLATE CORRESPONDS WITH THE WIDTH OF INNER PLATE - h2)

+ ONLY WITH ONE MIDDLE PLATE

CONNECTING ELEMENTS

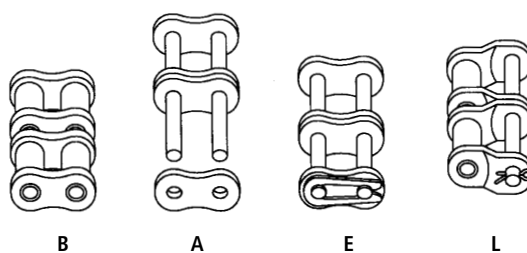

TRIPLEX STAINLESS STEEL ROLLER CHAINS

According to ČZ Standard

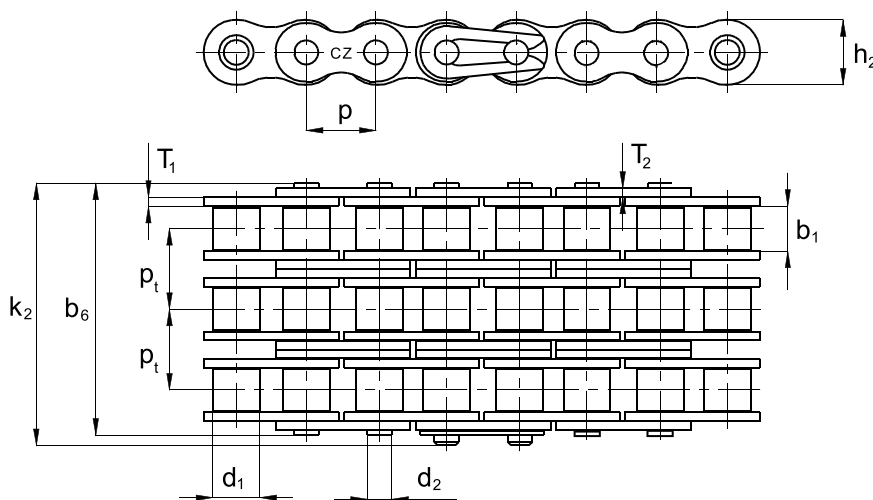

ISO DIN ČSN	PITCH	INSIDE WIDTH	ROLLER DIAMETER	PIN DIAMETER	PIN LENGTH	CONNECT. PIN LENGTH	INNER PLATE WIDTH	INNER PLATE THICKNESS	OUTER PLATE THICKNESS	TRANSVER. PITCH	BEARING AREA	WEIGHT	BREAKING LOAD	CONNECTING ELEMENTS		
														B	A	E
	p	b1	d1	d2	b6	k2	h2	T1	T2	pt	S	q	FB			
		min.	max.	max.	max.	max.	max.						min.			
	mm	mm	mm	mm	mm	mm	mm	mm	mm	mm	mm ²	kg/m	N			
06 B-3*+	9,525	5,72	6,35	3,28	32,90	34,55	8,20	1,20	1,00	10,24	84,00	1,12	13 000	•	•	•
08 B-3	12,7	7,75	8,51	4,45	44,25	46,20	11,80	1,60	1,40	13,92	150,80	2,04	36 000	•	•	•
10 B-3	15,875	9,65	10,16	5,08	51,90	53,55	14,50	1,60	1,60	16,59	201,90	2,66	39 200	•	•	•

*ONLY WITH STRAIGHT PLATES
+ONLY WITH ONE MIDDLE PLATE

CONNECTING ELEMENTS

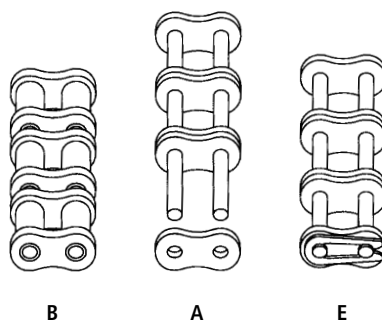

DOUBLE PITCH CHAINS

According to ČSN 02 3315, DIN 8181 and ISO 1275

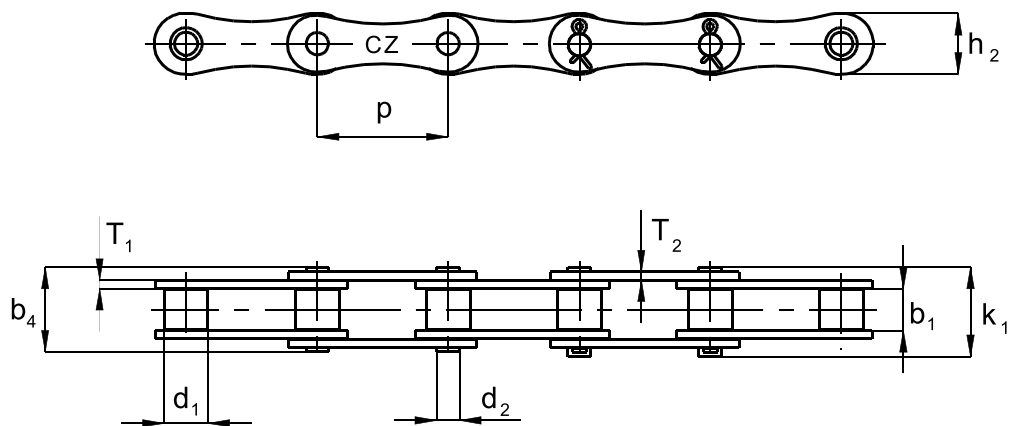

ISO DIN ČSN	PITCH	INSIDE WIDTH	ROLLER DIAMETER	PIN DIAMETER	PIN LENGHT	CONNECT. PIN LENGHT	INNER PLATE WIDTH	INNER PLATE THICKNESS	OUTER PLATE THICKNESS	BEARING AREA	WEIGHT	BREAKING LOAD	CONNECTING ELEMENTS				
	p	b1 min.	d1 max.	d2 max.	b4 max.	k1 max.	h2 max.	T1	T2	S	q	FB min.	B	A	S	L	C
	mm	mm	mm	mm	mm	mm	mm	mm	mm	mm ²	kg/m	N					
TYPE B (European design)																	
208 B	25,40	7,75	8,51	4,45	16,40	19,40	12,00	1,60	1,50	50,28	0,48	18 690
210 B	31,75	9,65	10,16	5,08	18,70	21,50	14,40	1,60	1,60	67,30	0,60	23 310
212 B	38,10	11,68	12,07	5,72	22,30	24,50	16,40	1,80	1,80	89,35	0,76	30 345
TYPE A (American design)																	
208 A	25,40	7,85	7,95	3,96	16,40	19,00	12,00	1,50	1,50	44,23	0,62	17 500
210 A	31,75	9,53	10,16	5,08	20,10	22,90	14,40	2,00	2,00	70,10	0,70	27 200
212 A	38,10	12,70	11,91	5,94	25,40	28,30	16,40	2,40	2,40	105,40	0,98	31 380

CONNECTING ELEMENTS

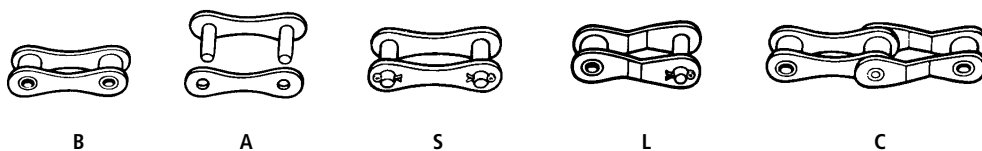

BUSH CHAINS

According to standards ISO 1395, DIN 8154, ASME B29.1M, ČSN 02 3321, ČZ

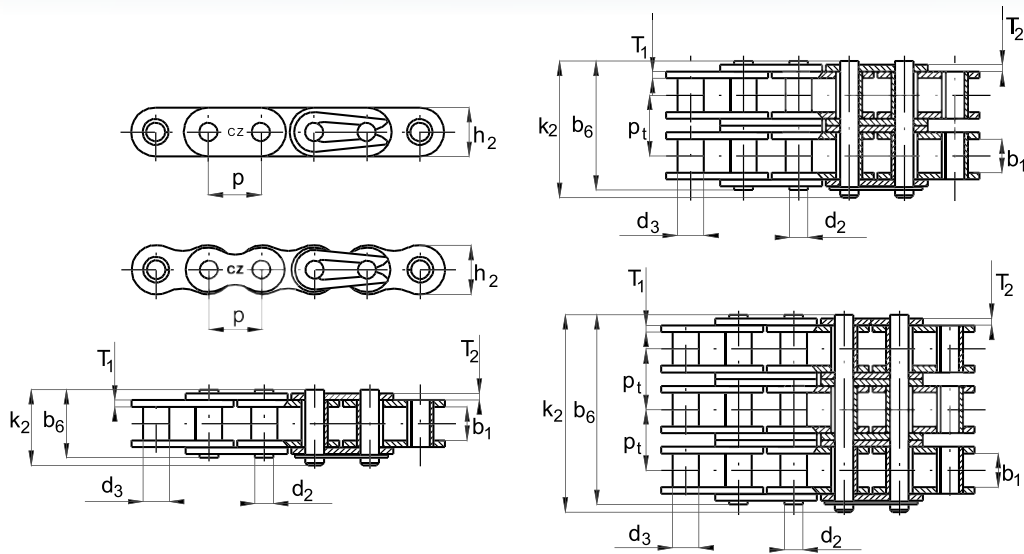

ISO DIN ČSN	TRADE MARK ČZ	PITCH	INSIDE WIDTH	BUSH DIAMETER	PIN DIAMETER	PIN LENGHT	CONNECT. PIN LENGHT	INNER PLATE WIDTH	INNER PLATE THICKNESS	OUTER PLATE THICKNESS	TRANS- VER. PITCH	BEARING AREA	WEIGHT	BREAKING LOAD	CONNECTING ELEMENTS				
															B	A	E	C	
		p	b1 min.	d3 max.	d2 max.	b6 max.	k2 max.	h2 max.	T1	T2	pt	S	q	FB min.					
		mm	mm	mm	mm	mm	mm	mm	mm	mm	mm	mm ²	kg/m	N					
	ČZ 219	7,774	4,60	4,59	3,00	12,15		7,55	1,40	1,30		23,70	0,30	9500	•	•			
062 C		9,525	9,52	6,00	4,18	17,80		9,25	1,80	1,20		56,01	0,59	12390	•	•		•	
06 C-1**	ČZ 35	9,525	4,77	5,08	3,58	12,00	13,30	8,80	1,20	1,20		26,74	0,39	8295	•	•	•	•	
	ČZ 35 STRONG	9,525	4,77	5,08	3,58	12,50	13,55	8,80	1,20	1,20		28,28	0,41	8830	•	•	•		
06 C-2*		9,525	4,77	5,08	3,58	22,10	23,45	8,80	1,20	1,20	10,13	53,48	0,76	17600	•	•	•		
06 C-3*		9,525	4,77	5,08	3,58	32,30	33,70	8,80	1,20	1,20	10,13	80,22	1,24	24530	•	•	•		
	3/8"x5/16"	9,525	7,75	5,00	3,32	15,90	17,20	9,25	1,60	1,20		37,08	0,45	11000	•	•	•		
	3/8"x7,5	9,525	7,50	5,00	3,32	15,90	17,20	9,25	1,60	1,20		37,08	0,45	11000	•	•	•		

*ONLY WITH STRAIGHT PLATES

**ALSO WITH SHAPED PLATES (THE WIDTH OF INNER PLATE h2 MAX = 9mm)

CONNECTING ELEMENTS

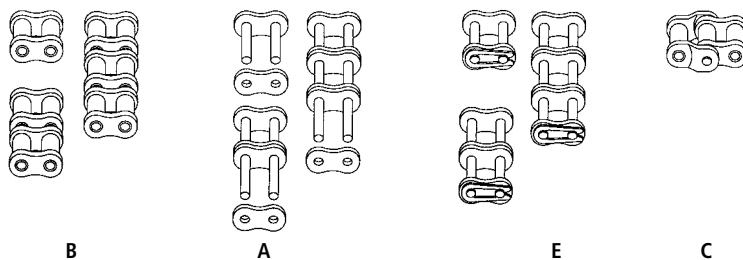

CONNECTING ELEMENTS

SIMPLEX

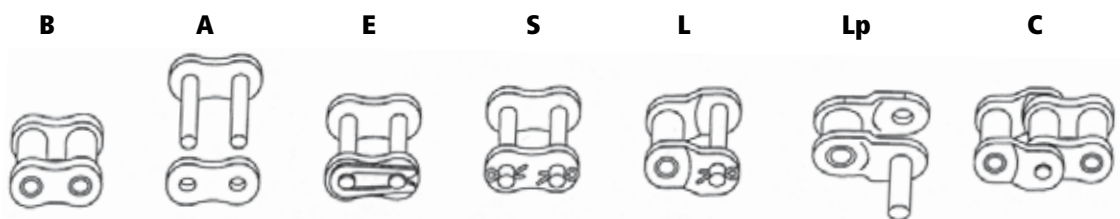

DUPLEX

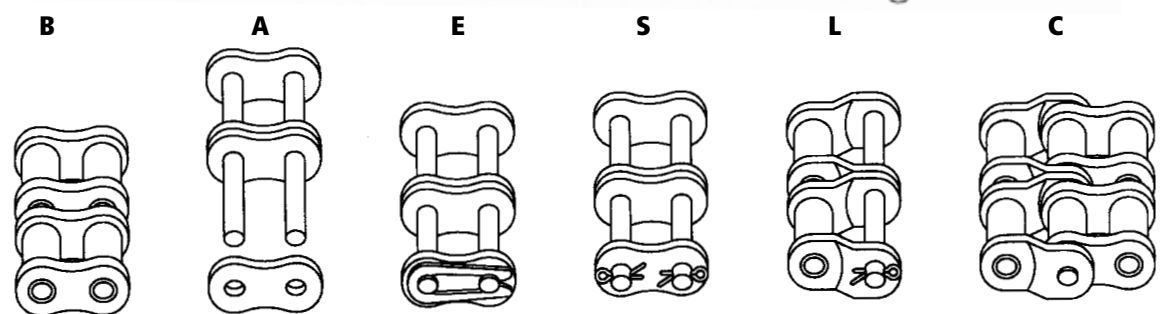

TRIPLEX

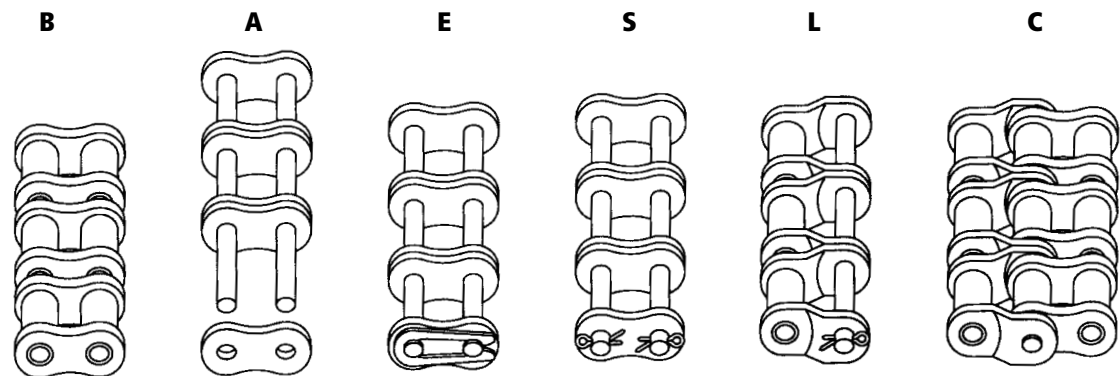

- B** inner link
- A** outer link - chain which is connected by this element cannot be disconnected without destruction.
- E** connecting link with spring clip - is the mostly used type of connecting element, which is very simple for manipulation, it is possible to perform assembling and disassembling frequently.
- S** connecting link with cotter - this type is used for slow motion transmissions, where we seldom perform the assembling and disassembling.
- L** offset (reduction) link - it is used for changing the number of links from even to odd (it decreases 30 % of the static strength).
- C** double offset (reduction) link - is used for changing the number of links from even to odd (it decreases 30 % of static strength). When mounting it is necessary to press the pins into the outer links and rivet them.
- Ep** solid connecting link with spring (with shouldered pins) - principal of connecting is same as at elemente, the connecting plate is pressed on the pin with small interference, in order to increase the dynamical strength of the element. It is possible to perform assembling and disassembling frequently.
- Lp** offset link with pin

ROLLER CHAINS WITH ATTACHMENTS

According to standards ČSN, ČZ

Simplex roller chains with attachments M1, R1, M2, R2	26–27
according to ČSN 02 3312	
according to ČZ standard	
according to ČZ standard in stainless steel modification	
Simplex roller chains with attachments M1, M2 outer/inner alternating	28
according to ČZ standard	
Simplex roller chains with attachments K1, L1, K2, L2	29–30
according to ČSN 02 3312	
according to ČZ standard	
according to ČZ standard in stainless steel modification	
Simplex roller chains with alternately outer and inner attachments (One side - K1, Both sides - K2)	31
according to ČZ standard	
Simplex roller chains with attachments M7, M8	32–33
according to ČZ standard	
according to ČZ standard in stainless steel modification	
Simplex roller chains with attachments K7, K8	34–35
according to ČZ standard	
according to ČZ standard in stainless steel modification	
Duplex roller chains with attachments M1, M2	36
according to ČZ standard	
Duplex roller chains with attachments K1, K2	37
according to ČZ standard	
Duplex roller chains with attachments M7, M8	38
according to ČZ standard	
Duplex roller chains with attachments K7, K8	39
according to ČZ standard	
Triplex roller chains with attachments M1, M2	40
according to ČZ standard	

ROLLER CHAINS WITH ATTACHMENTS

According to standards ČSN, ČZ

Triplex roller chains with attachments K1, K2	41
according to ČZ standard	
Triplex roller chains with attachments M7, M8	42
according to ČZ standard	
Triplex roller chains with attachments K7, K8	43
according to ČZ standard	
Double pitch chains with attachments M3, M4	44
according to ČSN 02 3316	
Double pitch chains with attachments K3, K4	45
according to ČSN 02 3316	
Attachments	46–60
according to ČZ standard	

Roller chains with attachments belong to special chains although their bearing part complies with roller or bush chains. These chains are used for various conveyors (that is why they are sometimes called conveyor chains), feeding mechanisms, etc. They are provided with differently shaped plates that can be assembled in the chain in various combinations. They are produced also in duplex and triplex modifications.

Some kinds of the most common plates are standardised i.e. their basic dimensions are determined by a standard and are marked with letters.

Attachments are used for fastening of other elements that perform required function, for example conveyor cross-bar. Attachments can be manufactured from plastic, provided with threads in attachment holes, etc. for special purposes.

ČZ Řetězy, Ltd. produces other shapes of attachments that are not mentioned in the catalogue and it is provided with machinery for fast fulfilment of customer's request concerning new shapes of attachments.

Combination and placing of plates depend on customer, or we can carry out the most suitable design with its following production.

Different solutions of chains with attachments than these mentioned in the catalogue are to be discussed with our workers to reach the best result and your satisfaction.

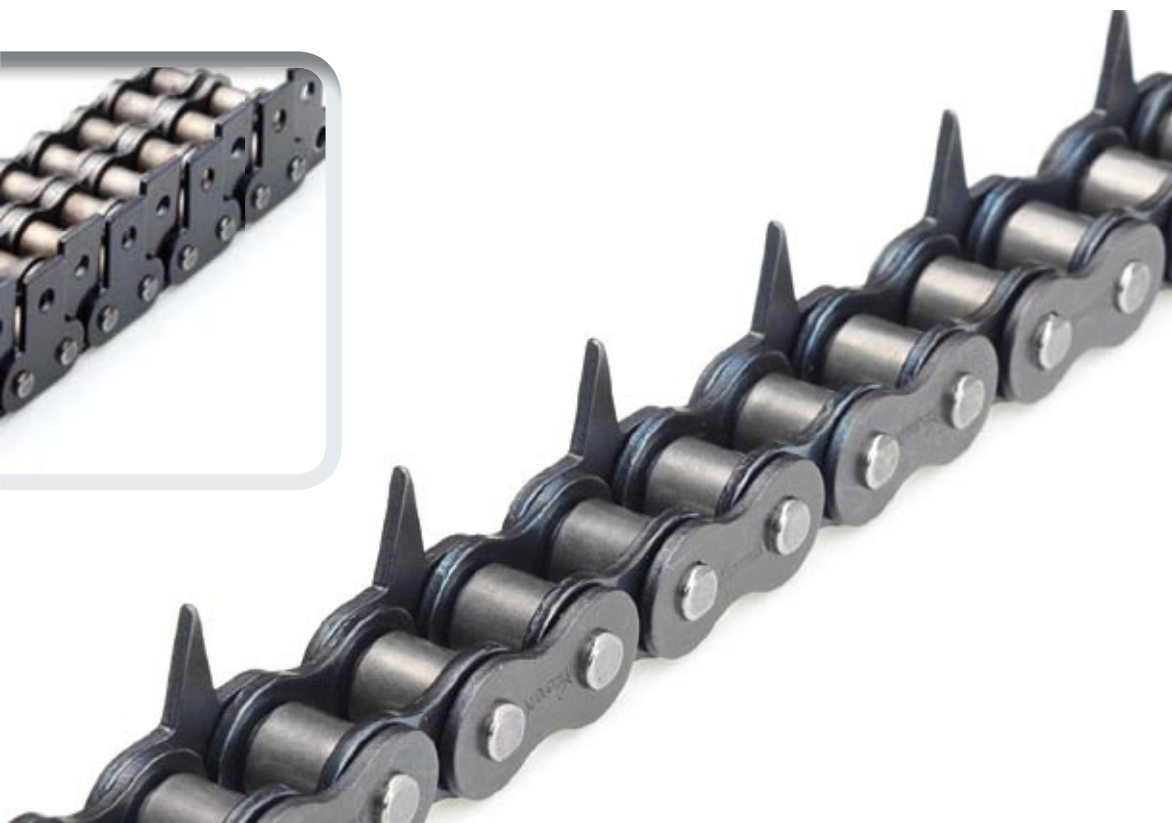
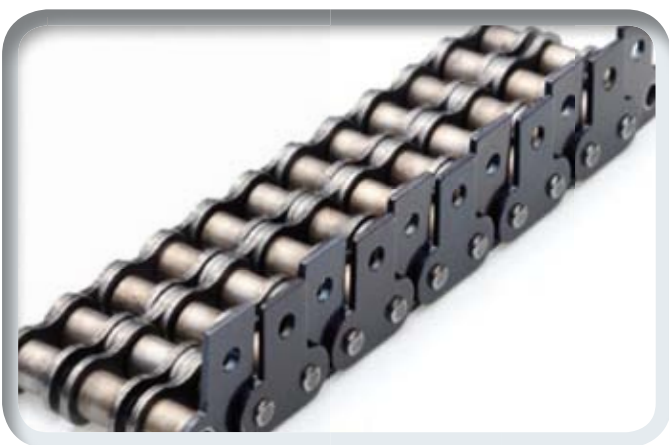

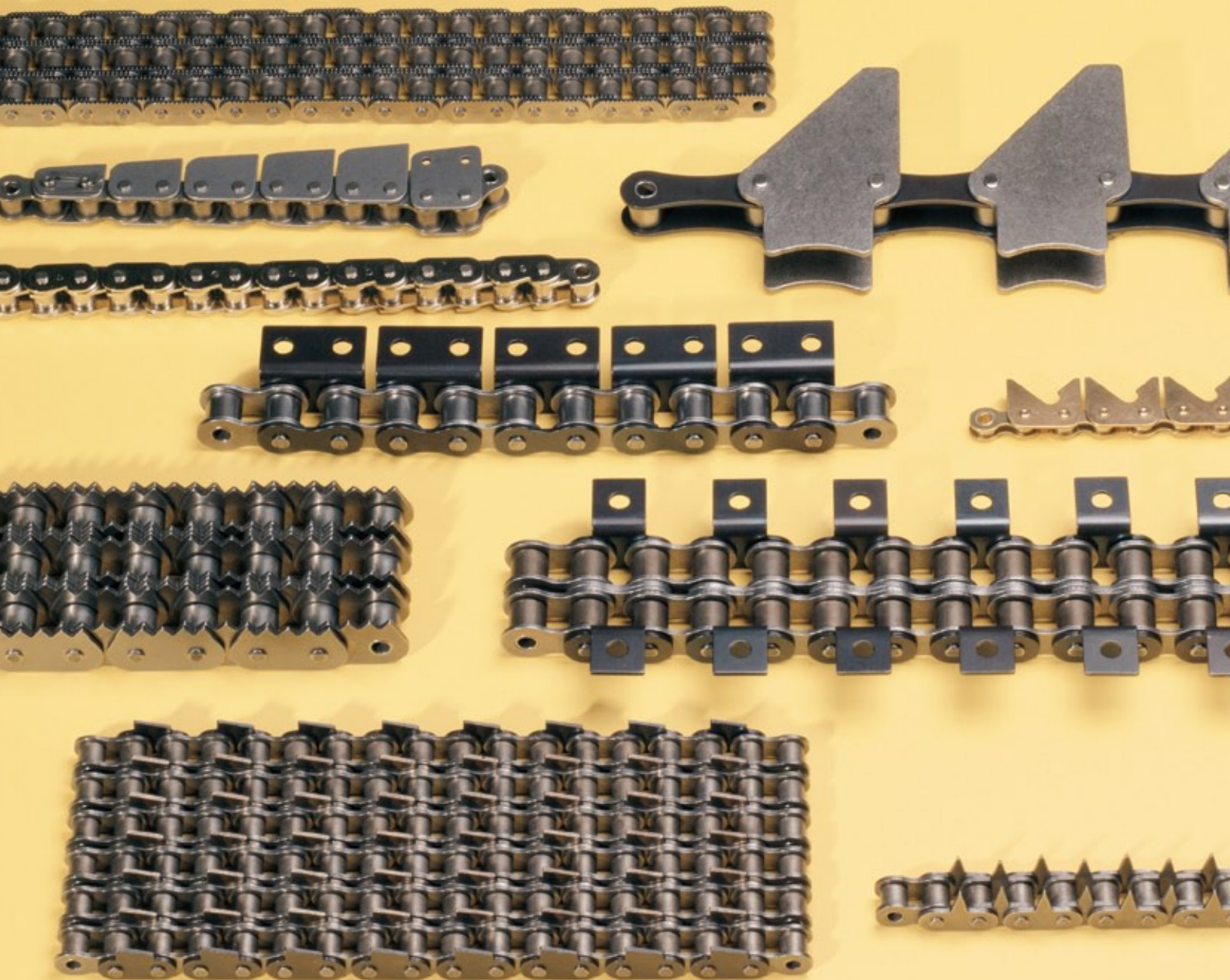

CHAINS WITH SPECIAL ATTACHMENTS

***- are used for direct transport of various goods
or fastening of other elements which perform
required function***

***Applications: conveyors in wood, furniture,
paper, typography, food and general
industry***

SIMPLEX ROLLER CHAINS WITH ATTACHMENTS M1, R1, M2, R2

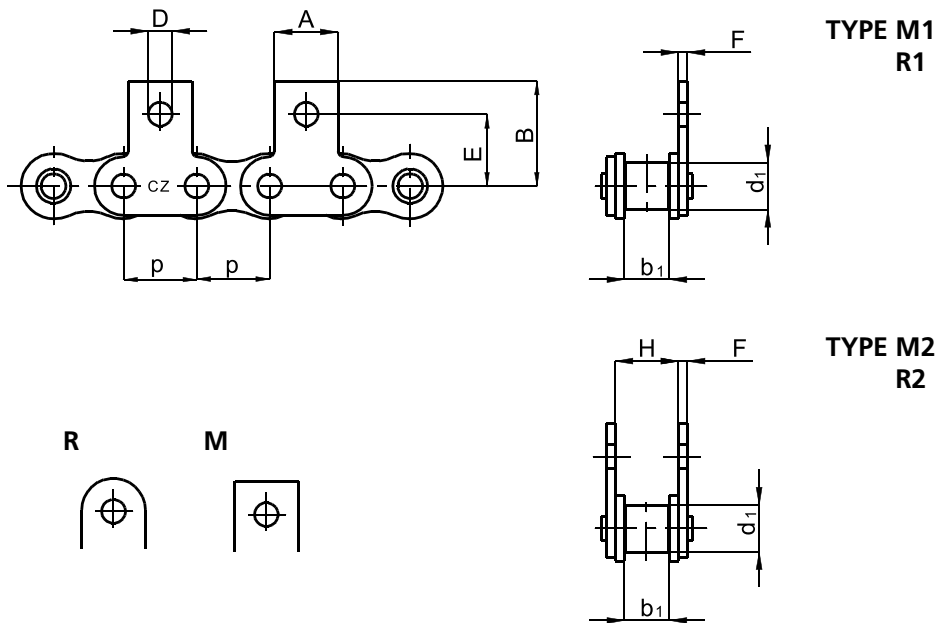

According to ČSN 02 3312

ČSN	PITCH	INSIDE WIDTH	ROLLER DIAMETER	DIMENSION	DIMENSION	ATTACHMENT HOLE DIAMETER	DIMENSION	DIMENSION	ATTACHMENT PLATE THICKNESS	WEIGHT	BREAKING LOAD
	p	b1 min.	d1 max.	A	B	D	E	H	F	q	FB min.
	mm	mm	mm	mm	mm	mm	mm	mm	mm	kg/m	N
06 B-1 M1	9,525	5,72	6,35	8,00	13,60	3,20	9,10	-	1,00	0,46	9 345
08 B-1 M1	12,7	7,75	8,51	11,50	19,00	4,30	13,00	-	1,40	0,79	18 690
10 B-1 M1	15,875	9,65	10,16	14,00	24,00	5,30	16,00	-	1,50	1,04	23 310
12 B-1 M1	19,05	11,68	12,07	17,00	30,00	6,40	21,00	-	1,80	1,39	30 345
12 B-1 R1	19,05	11,68	12,07	20,00	33,00	6,40	23,00	-	2,00	1,43	30 345
16 B-1 R1	25,4	17,02	15,88	25,00	43,00	8,40	30,50	-	3,00	3,06	65 000
06 B-1 M2	9,525	5,72	6,35	8,00	13,60	3,20	9,10	8,75	1,00	0,51	9 345
08 B-1 M2	12,7	7,75	8,51	11,50	19,00	4,30	13,00	11,50	1,40	0,87	18 690
10 B-1 M2	15,875	9,65	10,16	14,00	24,00	5,30	16,00	13,50	1,50	1,13	23 310
12 B-1 M2	19,05	11,68	12,07	17,00	30,00	6,40	21,00	15,80	1,80	1,53	30 345
12 B-1 R2	19,05	11,68	12,07	20,00	33,00	6,40	23,00	15,80	2,00	1,63	30 345
16 B-1 R2	25,4	17,02	15,88	25,00	43,00	8,40	30,50	25,80	3,00	3,44	65 000

The plates M1, R1, M2, R2 position must be consulted with producer

SIMPLEX ROLLER CHAINS WITH ATTACHMENTS M1, R1, M2, R2

ČZ Standard

TRADE MARK ČZ	PITCH	INSIDE WIDTH	ROLLER DIAMETER (BUSH)	DIMENSION	DIMENSION	ATTACHMENT HOLE DIAMETER	DIMENSION	DIMENSION	ATTACHMENT PLATE THICKNESS	WEIGHT	BREAKING LOAD
	p	b1 min.	d1 max.	A	B	D	E	H	F	q	FB min.
	mm	mm	mm	mm	mm	mm	mm	mm	mm	kg/m	N
06 C-1 M1	9,525	4,77	5,08 BUSH	8,00	13,60	3,20	9,10	-	1,00	0,38	8 000
081 M1	12,7	3,30	7,75	10,50	17,10	4,10	11,10	-	1,00	0,35	8 200
1/2"x3/16" MOFA M1	12,7	4,88	7,75	11,50	19,00	4,30	13,00	-	1,40	0,58	15 750
1/2"x1/4" MOFA M1	12,7	6,40	7,75	11,50	19,00	4,30	13,00	-	1,40	0,70	15 750
086 M1	12,7	5,30	8,51	11,50	19,00	4,30	13,00	-	1,40	0,79	18 690
10 A-1 M1	15,875	9,53	10,16	14,00	24,00	5,30	16,00	-	1,60	0,84	23 310
16 B-1 M1	25,4	17,02	15,88	24,00	39,10	8,40	30,50	-	3,00	3,13	65 000
081 M2	12,7	3,30	7,75	10,50	17,10	4,10	11,10	6,00	1,00	0,39	8 200
1/2"x3/16" MOFA M2	12,7	4,88	7,75	11,50	19,00	4,30	13,00	8,20	1,40	0,64	15 750
086 M2	12,7	5,30	8,51	11,50	19,00	4,30	13,00	9,00	1,40	0,70	18 690
16 B-1 M2	25,4	17,02	15,88	24,00	39,10	8,40	30,50	25,80	3,00	3,38	65 000

The plates M1, R1, M2, R2 position must be consulted with producer

Standard ČZ in stainless steel modification

TRADE MARK ČZ	PITCH	INSIDE WIDTH	ROLLER DIAMETER	DIMENSION	DIMENSION	ATTACHMENT HOLE DIAMETER	DIMENSION	DIMENSION	ATTACHMENT PLATE THICKNESS	WEIGHT	BREAKING LOAD
	p	b1 min.	d1 max.	A	B	D	E	H	F	q	FB min.
	mm	mm	mm	mm	mm	mm	mm	mm	mm	kg/m	N
06 B-1 M1	9,525	5,72	6,35	8,00	13,60	3,20	9,10	-	1,00	0,46	5 350
08 B-1 M1	12,7	7,75	8,51	11,50	19,00	4,30	13,00	-	1,40	0,79	12 000
10 B-1 M1	15,875	9,65	10,16	14,00	24,00	5,30	16,00	-	1,50	1,04	14 200
12 B-1 M1	19,05	11,68	12,07	17,00	30,00	6,40	21,00	-	1,80	1,39	18 000
06 B-1 M2	9,525	5,72	6,35	8,00	13,60	3,20	9,10	8,75	1,00	0,51	5 350
08 B-1 M2	12,7	7,75	8,51	11,50	19,00	4,30	13,00	11,50	1,40	0,87	12 000
10 B-1 M2	15,875	9,65	10,16	14,00	24,00	5,30	16,00	13,50	1,50	1,13	14 200
12 B-1 M2	19,05	11,68	12,07	17,00	30,00	6,40	21,00	15,80	1,80	1,53	18 000

The plates M1, R1, M2, R2 position must be consulted with producer

SIMPLEX ROLLER CHAINS WITH ATTACHMENTS M1, M2 OUTER/INNER ALTERNATING

Standard ČZ

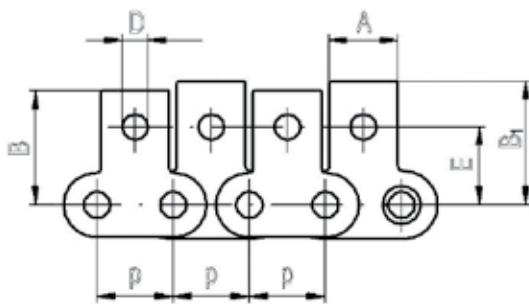

TYPE M1

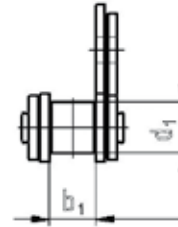

TYPE M2

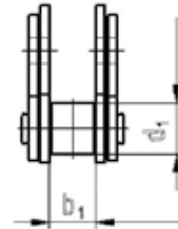

ČSN	PITCH	INSIDE WIDTH	ROLLER DIAMETER	DIMENSION	DIMENSION	DIMENSION	ATTACHMENT HOLE DIAMETER	DIMENSION	BREAKING LOAD
	p	b1 min.	d1 max.	A	B	B1	D	E	FB min.
	mm	mm	mm	mm	mm	mm	mm	mm	N
08 B-1	12,7	7,75	8,51	11,50	19,00	20,60	4,30	13,00	18 690
10 B-1	15,875	9,65	10,16	14,00	24,00	25,55	5,30	16,00	23 310
12 B-1	19,05	11,68	12,07	17,00	30,00	30,00	6,40	21,00	30 345

SIMPLEX ROLLER CHAINS WITH ATTACHMENTS K1, L1, K2, L2

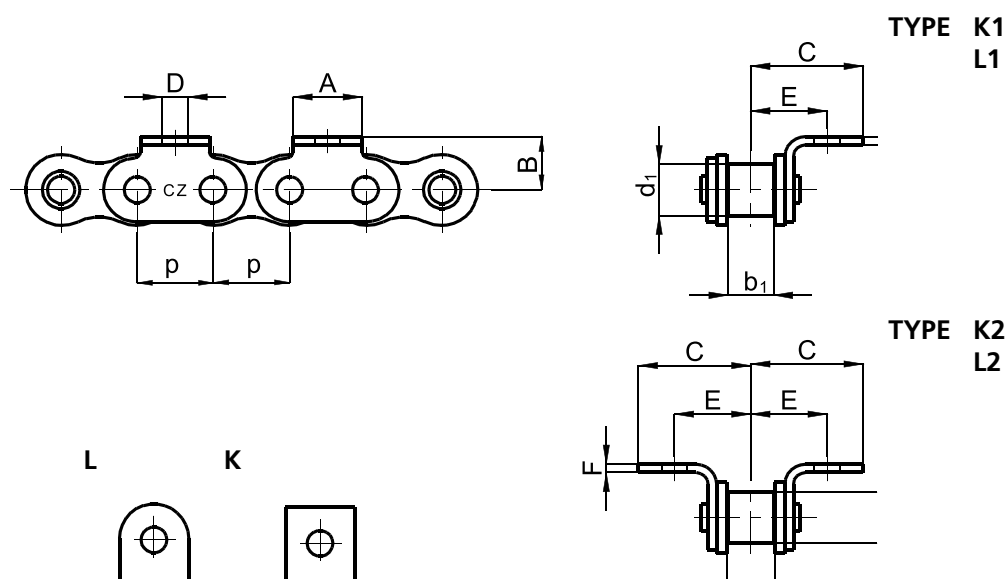

According to ČSN 02 3312

ČSN	PITCH	INSIDE WIDTH	ROLLER DIAMETER	DIMENSION	DIMENSION	ATTACHMENT HOLE DIAMETER	DIMENSION	DIMENSION	ATTACHMENT PLATE THICKNESS	WEIGHT	BREAKING LOAD
	p	b ₁ min.	d ₁ max.	A	B	D	E	C	F	q	FB min.
	mm	mm	mm	mm	mm	mm	mm	mm	mm	kg/m	N
06 B-1 K1	9,525	5,72	6,35	8,00	6,50	3,20	9,00	13,50	1,00	0,46	9 345
08 B-1 K1	12,7	7,75	8,51	11,50	8,90	4,30	12,70	18,70	1,40	0,79	18 690
10 B-1 K1	15,875	9,65	10,16	14,00	10,30	5,30	15,875	23,87	1,60	1,04	23 310
12 B-1 K1	19,05	11,68	12,07	17,00	13,45	6,40	19,05	28,05	1,80	1,39	30 345
12 B-1 L1	19,05	11,68	12,70	20,00	12,00	6,40	22,85	32,85	2,00	1,43	30 345
16 B-1 L1	25,4	17,02	15,88	25,00	19,50	8,40	30,20	42,70	3,00	3,06	65 000
06 B-1 K2	9,525	5,72	6,35	8,00	6,50	3,20	9,00	13,50	1,00	0,51	9 345
08 B-1 K2	12,7	7,75	8,51	11,50	8,90	4,30	12,70	18,70	1,40	0,87	18 690
10 B-1 K2	15,875	9,65	10,16	14,00	10,30	5,30	15,875	23,87	1,60	1,13	23 310
12 B-1 K2	19,05	11,68	12,07	17,00	13,45	6,40	19,05	28,05	1,80	1,53	30 345
12 B-1 L2	19,05	11,68	12,07	20,00	12,00	6,40	22,85	32,85	2,00	1,63	30 345
16 B-1 L2	25,4	17,02	15,88	25,00	19,50	8,40	30,20	42,70	3,00	3,44	65 000

The plates M1, K1, L1, K2, L2 position must be consulted with producer

SIMPLEX ROLLER CHAINS WITH ATTACHMENTS K1, L1, K2, L2

Design according to ČSN 02 3312

ČZ Standard

TRADE MARK ČZ	PITCH	INSIDE WIDTH	ROLLER DIAMETER	DIMENSION	DIMENSION	ATTACHMENT HOLE DIAMETER	DIMENSION	DIMENSION	ATTACHMENT PLATE THICKNESS	WEIGHT	BREAKING LOAD
	p	b1 min.	d1 max.	A	B	D	E	C	F	q	FB min.
	mm	mm	mm	mm	mm	mm	mm	mm	mm	kg/m	N
081 K1	12,7	3,30	7,75	10,50	7,00	4,10	9,00	15,55	1,00	0,35	8 200
1/2"x3/16" VELO K1	12,7	4,88	7,75	10,50	7,00	4,10	9,70	16,30	1,00	0,39	8 400
1/2"x3/16" V.T. K1	12,7	4,88	7,75	11,50	8,90	4,30	11,10	17,10	1,40	0,58	10 500
1/2"x3/16" MOFA K1	12,7	4,88	7,75	11,50	8,90	4,30	11,10	17,10	1,40	0,58	15 750
1/2"x3/16" MOFA K1	12,7	4,88	7,75	11,50	8,90	6,40	11,10	17,10	1,40	0,58	15 750
1/2"x1/4" MOFA K1	12,7	6,40	7,75	11,50	8,90	4,30	11,90	17,90	1,40	0,58	15 750
086 K1	12,7	5,30	8,51	11,50	8,90	4,30	11,50	17,50	1,40	0,70	18 690
12 A-1 K1	19,05	12,70	11,91	17,00	13,45	6,40	20,10	29,10	1,80	1,67	30 345
16 B-1 K1	25,4	17,02	15,88	24,00	20,20	8,40	28,80	37,40	3,00	3,13	65 000
081 K2	12,7	3,30	7,75	10,50	7,00	4,10	9,00	15,55	1,00	0,39	8 200
086 K2	12,7	5,30	8,51	11,50	8,90	4,30	11,50	17,50	1,40	0,79	18 690
16 B-1 K2	25,4	17,02	15,88	24,00	20,20	8,40	28,80	37,40	3,00	3,38	65 000

The plates K1, K2 position must be consulted with producer

Standard ČZ in stainless steel modification

TRADE MARK ČZ	PITCH	INSIDE WIDTH	ROLLER DIAMETER	DIMENSION	DIMENSION	ATTACHMENT HOLE DIAMETER	DIMENSION	DIMENSION	ATTACHMENT PLATE THICKNESS	WEIGHT	BREAKING LOAD
	p	b1 min.	d1 max.	A	B	D	E	C	F	q	FB min.
	mm	mm	mm	mm	mm	mm	mm	mm	mm	kg/m	N
06 B-1 K1	9,525	5,72	6,35	8,00	6,50	3,20	9,00	13,50	1,00	0,46	5 350
08 B-1 K1	12,7	7,75	8,51	11,50	8,90	4,30	12,70	18,70	1,40	0,79	12 000
10 B-1 K1	15,875	9,65	10,16	14,00	10,30	5,30	15,875	23,87	1,60	1,04	14 200
12 B-1 K1	19,05	11,68	12,07	17,00	13,45	6,40	19,05	28,05	1,80	1,39	18 000
06 B-1 K2	9,525	5,72	6,35	8,00	6,50	3,20	9,00	13,50	1,00	0,51	5 350
08 B-1 K2	12,7	7,75	8,51	11,50	8,90	4,30	12,70	18,70	1,40	0,87	12 000
10 B-1 K2	15,875	9,65	10,16	14,00	10,30	5,30	15,875	23,87	1,60	1,13	14 200
12 B-1 K2	19,05	11,68	12,07	17,00	13,45	6,40	19,05	28,05	1,80	1,53	18 000

The plates K1, K2 position must be consulted with producer

SIMPLEX ROLLER CHAINS WITH ALTERNATELY OUTER AND INNER ATTACHMENTS (ONE SIDE - K1, BOTH SIDERS - K2)

ČZ Standard

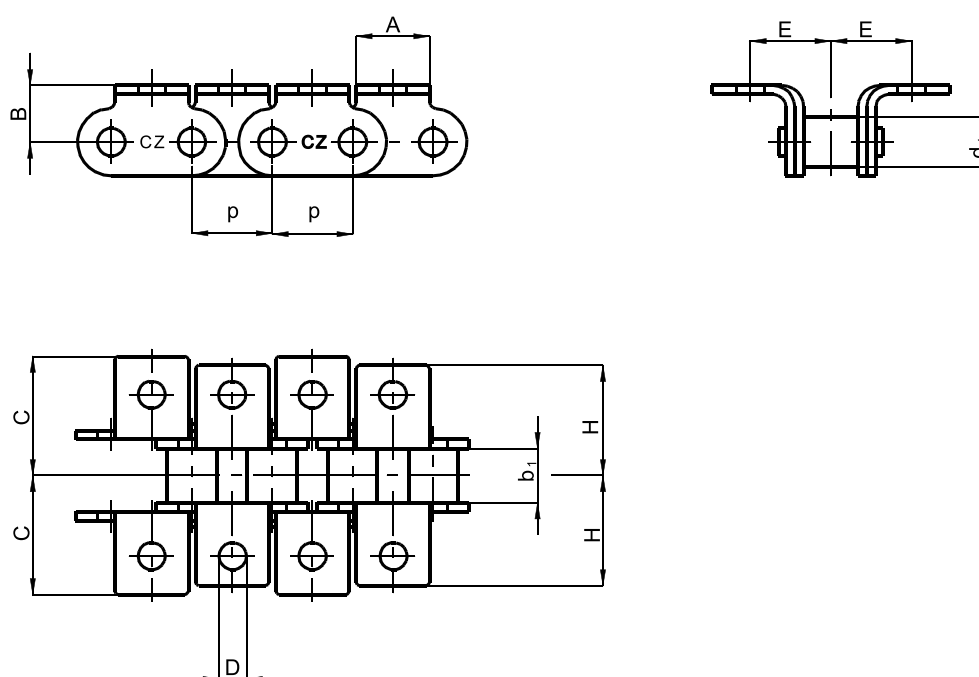

TRADE MARK ČZ	PITCH	INSIDE WIDTH	ROLLER DIAMETER	DIMENSION	DIMENSION	ATTACHMENT HOLE DIAMETER	DIMENSION	DIMENSION	DIMENSION	BREAKING LOAD
	p	b1 min.	d1 max.	A	B	D	E	C	H	FB min.
	mm	mm	mm	mm	mm	mm	mm	mm	mm	N
08 B-1	12,7	7,75	8,51	11,50	8,90	4,30	12,70	18,70	18,70	18 690
10 B-1	15,875	9,65	10,16	14,00	10,30	5,30	15,875	23,87	22,375	23 310
12 B-1	19,05	11,68	12,07	17,00	13,45	6,40	19,05	28,05	26,05	30 345

SIMPLEX ROLLER CHAINS WITH ATTACHMENTS M7, M8

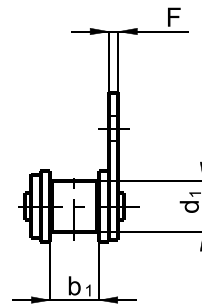
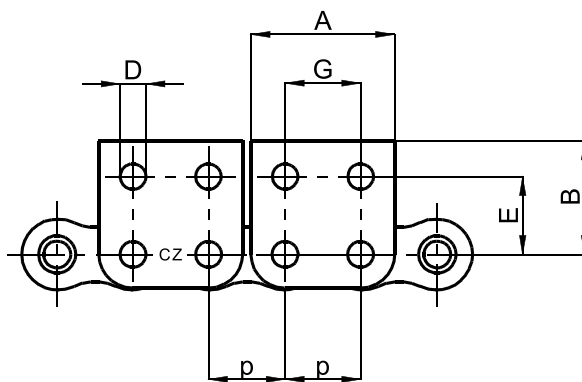

TYPE M7

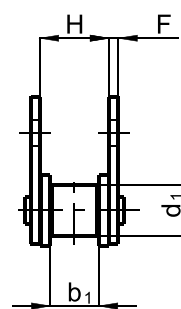

TYPE M8

Standard ČZ in stainless steel modification

TRADE MARK ČZ	PITCH	INSIDE WIDTH	ROLLER DIAMETER	DIMENSION	DIMENSION	ATTACHMENT HOLE DIAMETER	DIMENSION	DIMENSION	ATTACHMENT PLATE THICKNESS	ATTACHMENT HOLES DISTANCE	WEIGHT	BREAKING LOAD
	p	b1 min.	d1 max.	A	B	D	E	H	F	G	q	FB min.
	mm	mm	mm	mm	mm	mm	mm	mm	mm	mm	kg/m	N
06 B-1 M7	9,525	5,72	6,35	17,80	12,30	3,20	9,10	-	1,00	9,53	0,45	5 350
08 B-1 M7	12,7	7,75	8,51	24,00	19,00	4,30	13,00	-	1,50	12,70	0,84	12 000
10 B-1 M7	15,875	9,65	10,16	28,70	24,25	5,30	16,25	-	1,50	15,87	1,10	14 200
12 B-1 M7	19,05	11,68	12,07	34,15	30,00	6,40	21,00	-	1,80	19,05	1,30	18 000
06 B-1 M8	9,525	5,72	6,35	17,80	12,30	3,20	9,10	8,65	1,00	9,53	0,50	5 350
08 B-1 M8	12,7	7,75	8,51	24,00	19,00	4,30	13,00	11,50	1,50	12,70	0,99	12 000
10 B-1 M8	15,875	9,65	10,16	28,70	24,25	5,30	16,25	13,50	1,50	15,87	1,30	14 200
12 B-1 M8	19,05	11,68	12,07	34,15	30,00	6,40	21,00	15,80	1,80	19,05	1,90	18 000

The plates M7, M8 position must be consulted with producer

SIMPLEX ROLLER CHAINS WITH ATTACHMENTS M7, M8

ČZ Standard

TRADE MARK ČZ	PITCH	INSIDE WIDTH	ROLLER DIAMETER	DIMENSION	DIMENSION	ATTACHMENT HOLE DIAMETER	DIMENSION	DIMENSION	ATTACHMENT PLATE THICKNESS	ATTACHMENT HOLES DISTANCE	WEIGHT	BREAKING LOAD
	p	b1 min.	d1 max.	A	B	D	E	H	F	G	q	FB min.
	mm	mm	mm	mm	mm	mm	mm	mm	mm	mm	kg/m	N
06 B-1 M7	9,525	5,72	6,35	17,80	12,30	3,20	9,10	-	1,00	9,53	0,45	9 345
1/2" x 3/16" V.T. M7	12,7	4,88	7,75	24,00	19,00	4,30	13,00	-	1,50	12,70	0,65	10 500
1/2" x 3/16" MOFA M7	12,7	4,88	7,75	24,00	19,00	4,30	13,00	-	1,50	12,70	0,65	15 750
086 M7	12,7	5,30	8,51	24,00	19,00	4,30	13,00	-	1,50	12,70	0,77	18 690
08 B-1 M7	12,7	7,75	8,51	24,00	19,00	4,30	13,00	-	1,50	12,70	0,84	18 690
10 B-1 M7	15,875	9,65	10,16	28,70	24,25	5,30	16,25	-	1,50	15,87	1,10	23 310
12 B-1 M7	19,05	11,68	12,07	34,15	30,00	6,40	21,00	-	1,80	19,05	1,30	30 345
16 B-1 M7	25,4	17,02	15,88	45,50	39,10	8,40	30,50	-	3,00	25,40	3,30	65 000
06 B-1 M8	9,525	5,72	6,35	17,80	12,30	3,20	9,10	8,65	1,00	9,53	0,50	9 345
1/2" x 3/16" V.T. M8	12,7	4,88	7,75	24,00	19,00	4,30	13,00	8,20	1,50	12,70	0,65	10 500
1/2" x 3/16" MOFA M8	12,7	4,88	7,75	24,00	19,00	4,30	13,00	8,20	1,50	12,70	0,65	15 750
086 M8	12,7	5,30	8,51	24,00	19,00	4,30	13,00	9,00	1,50	12,70	0,77	18 690
08 B-1 M8	12,7	7,75	8,51	24,00	19,00	4,30	13,00	11,50	1,50	12,70	0,99	18 690
10 B-1 M8	15,875	9,65	10,16	28,70	24,25	5,30	16,25	13,50	1,50	15,87	1,30	23 310
12 A-1 M8	19,05	12,70	11,91	34,15	30,00	6,40	21,00	18,00	1,80	19,05	2,00	30 345
12 B-1 M8	19,05	11,68	12,07	34,15	30,00	6,40	21,00	15,80	1,80	19,05	1,90	30 345
16 B-1 M8	25,4	17,02	15,88	45,50	39,10	8,40	30,50	25,80	3,00	25,40	3,94	65 000

The plates M7, M8 position must be consulted with producer

SIMPLEX ROLLER CHAINS WITH ATTACHMENTS K7, K8

ČZ Standard

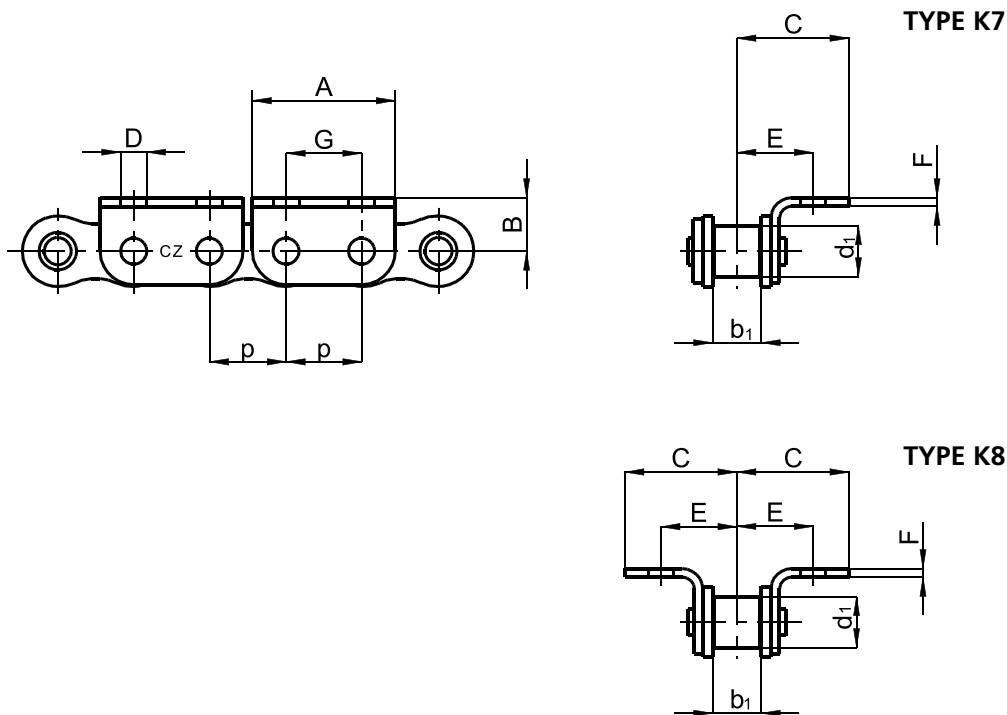

Standard ČZ in stainless steel modification

TRADE MARK ČZ	PITCH	INSIDE WIDTH	ROLLER DIAMETER	DIMENSION	DIMENSION	ATTACHMENT HOLE DIAMETER	DIMENSION	DIMENSION	ATTACHMENT PLATE THICKNESS	ATTACHMENT HOLES DISTANCE	WEIGHT	BREAKING LOAD
	p	b1 min.	d1 max.	A	B	D	E	C	F	G	q	FB min.
	mm	mm	mm	mm	mm	mm	mm	mm	mm	mm	kg/m	N
06 B-1 K7	9,525	5,72	6,35	17,80	6,50	3,20	9,00	12,20	1,00	9,53	0,45	5 350
08 B-1 K7	12,7	7,75	8,51	24,00	8,90	4,30	12,70	18,70	1,50	12,70	0,84	12 000
10 B-1 K7	15,875	9,65	10,16	28,70	10,30	5,30	15,875	23,87	1,50	15,87	1,10	14 200
12 B-1 K7	19,05	11,68	12,07	34,15	13,45	6,40	19,05	28,05	1,80	19,05	1,30	18 000
06 B-1 K8	9,525	5,72	6,35	17,80	6,50	3,20	9,00	12,20	1,00	9,53	0,50	5 350
08 B-1 K8	12,7	7,75	8,51	24,00	8,90	4,30	12,70	18,70	1,50	12,70	0,99	12 000
10 B-1 K8	15,875	9,65	10,16	28,70	10,30	5,30	15,875	23,87	1,50	15,87	1,30	14 200
12 B-1 K8	19,05	11,68	12,07	34,15	13,45	6,40	19,05	28,05	1,80	19,05	1,90	18 000

The plates K7, K8 position must be consulted with producer

SIMPLEX ROLLER CHAINS WITH ATTACHMENTS K7, K8

ČZ Standard

ČZ Standard

TRADE MARK ČZ	PITCH	INSIDE WIDTH	ROLLER DIAMETER	DIMENSION	DIMENSION	ATTACHMENT HOLE DIAMETER	DIMENSION	DIMENSION	ATTACHMENT PLATE THICKNESS	ATTACHMENT HOLES DISTANCE	WEIGHT	BREAKING LOAD
	p	b1 min.	d1 max.	A	B	D	E	C	F	G	q	FB min.
	mm	mm	mm	mm	mm	mm	mm	mm	mm	mm	kg/m	N
06 B-1 K7	9,525	5,72	6,35	17,80	6,50	3,20	9,00	12,20	1,00	9,53	0,45	9 345
086 K7	12,7	5,30	8,51	24,00	8,90	4,30	11,50	17,50	1,50	12,70	0,77	18 690
08 B-1 K7	12,7	7,75	8,51	24,00	8,90	4,30	12,70	18,70	1,50	12,70	0,84	18 690
10 B-1 K7	15,875	9,65	10,16	28,70	10,30	5,30	15,875	23,87	1,50	15,87	1,10	23 310
12 B-1 K7	19,05	11,68	12,07	34,15	13,45	6,40	19,05	28,05	1,80	19,05	1,30	30 345
16 B-1 K7	25,4	17,02	15,88	45,50	20,20	8,40	28,80	37,40	3,00	25,40	3,30	65 000
06 B-1 K8	9,525	5,72	6,35	17,80	6,50	3,20	9,00	12,20	1,00	9,53	0,50	9 345
086 K8	12,7	5,30	8,51	24,00	8,90	4,30	11,50	17,50	1,50	12,70	0,77	18 690
08 B-1 K8	12,7	7,75	8,51	24,00	8,90	4,30	12,70	18,70	1,50	12,70	0,99	18 690
10 B-1 K8	15,875	9,65	10,16	28,70	10,30	5,30	15,875	23,87	1,50	15,87	1,30	23 310
12 B-1 K8	19,05	11,68	12,07	34,15	13,45	6,40	19,05	28,05	1,80	19,05	1,90	30 345
16 B-1 K8	25,4	17,02	15,88	45,50	20,20	8,40	28,80	37,40	3,00	25,40	3,94	65 000

The plates K7, K8 position must be consulted with producer

DUPLEX ROLLER CHAINS WITH ATTACHMENTS M1, M2

ČZ Standard

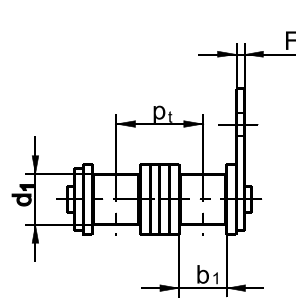
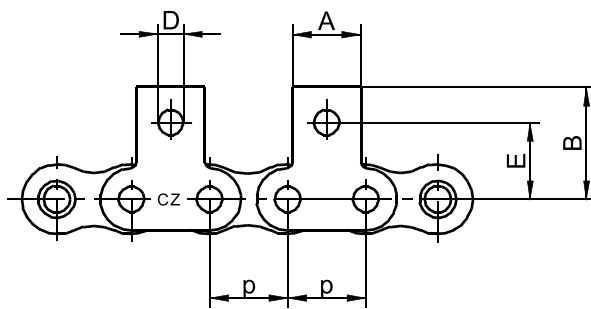

TYPE M1

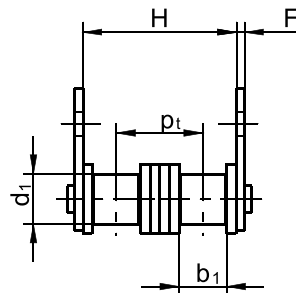

TYPE M2

TRADE MARK ČZ	PITCH	INSIDE WIDTH	ROLLER DIAMETER	DIMENSION	DIMENSION	ATTACHMENT HOLE DIAMETER	DIMENSION	DIMENSION	ATTACHMENT PLATE THICKNESS	TRANSVER. PITCH	BREAKING LOAD
	p	b1 min.	d1 max.	A	B	D	E	H	F	pt	FB min.
	mm	mm	mm	mm	mm	mm	mm	mm	mm	mm	N
06 B-2 M1+	9,525	5,72	6,35	8,00	13,60	3,20	9,10	-	1,00	10,24	17 745
06 B-2 M2+	9,525	5,72	6,35	8,00	13,60	3,20	9,10	19,00	1,00	10,24	17 745
08 B-2 M1	12,7	7,75	8,51	11,50	19,00	4,30	13,00	-	1,40	13,92	32 655
08 B-2 M2	12,7	7,75	8,51	11,50	19,00	4,30	13,00	25,45	1,40	13,92	32 655
10 B-2 M1	15,875	9,65	10,16	14,00	24,00	5,30	16,00	-	1,50	16,59	46 726
10 B-2 M2	15,875	9,65	10,16	14,00	24,00	5,30	16,00	30,00	1,50	16,59	46 726
12 B-2 M1	19,05	11,68	12,07	17,00	30,00	6,40	21,00	-	1,80	19,46	60 690
12 B-2 M2	19,05	11,68	12,07	17,00	30,00	6,40	21,00	35,35	1,80	19,46	60 690
16 B-2 M1	25,4	17,02	15,88	24,00	39,10	8,40	30,50	-	3,00	31,88	130 000
16 B-2 M2	25,4	17,02	15,88	24,00	39,10	8,40	30,50	57,80	3,00	31,88	130 000

+MIDDLE LINK PLATE CONTAINS ONE SOLID PLATE
The plates M1, M2 position must be consulted with producer

DUPLEX ROLLER CHAINS WITH ATTACHMENTS K1, K2

ČZ Standard

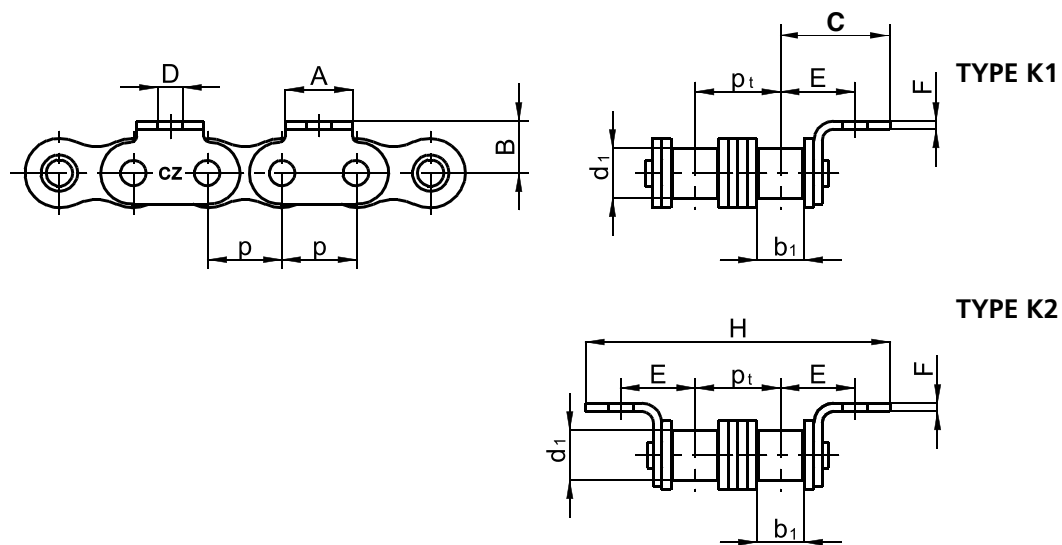

TRADE MARK ČZ	PITCH	INSIDE WIDTH	ROLLER DIAMETER	DIMENSION	DIMENSION	ATTACHMENT HOLE DIAMETER	DIMENSION	DIMENSION	DIMENSION	ATTACHMENT PLATE THICKNESS	TRANSVER. PITCH	BREAKING LOAD
	p	b ₁ min.	d ₁ max.	A	B	D	C	E	H	F	pt	FB min.
	mm	mm	mm	mm	mm	mm	mm	mm	mm	mm	mm	N
06 B-2 K1+	9,525	5,72	6,35	8,00	6,50	3,20	13,50	9,00	-	1,00	10,24	17 745
06 B-2 K2+	9,525	5,72	6,35	8,00	6,50	3,20	13,50	9,00	37,24	1,00	10,24	17 745
08 B-2 K1	12,7	7,75	8,51	11,50	8,90	4,30	18,70	12,70	-	1,40	13,92	32 655
08 B-2 K2	12,7	7,75	8,51	11,50	8,90	4,30	18,70	12,70	51,30	1,40	13,92	32 655
10 B-2 K1	15,875	9,65	10,16	14,00	10,30	5,30	23,87	15,875	-	1,50	16,59	46 726
10 B-2 K2	15,875	9,65	10,16	14,00	10,30	5,30	23,87	15,875	64,30	1,50	16,59	46 726
12 B-2 K1	19,05	11,68	12,07	17,00	13,45	6,40	28,05	19,05	-	1,80	19,46	60 690
12 B-2 K2	19,05	11,68	12,07	17,00	13,45	6,40	28,05	19,05	75,60	1,80	19,46	60 690
16 B-2 K1	25,4	17,02	15,88	24,00	20,20	8,40	37,40	28,80	-	3,00	31,88	130 000
16 B-2 K2	25,4	17,02	15,88	24,00	20,20	8,40	37,40	28,80	107,00	3,00	31,88	130 000

+MIDDLE LINK PLATE CONTAINS ONE SOLID PLATE
The plates K1, K2 position must be consulted with producer

DUPLEX ROLLER CHAINS WITH ATTACHMENTS M7, M8

ČZ Standard

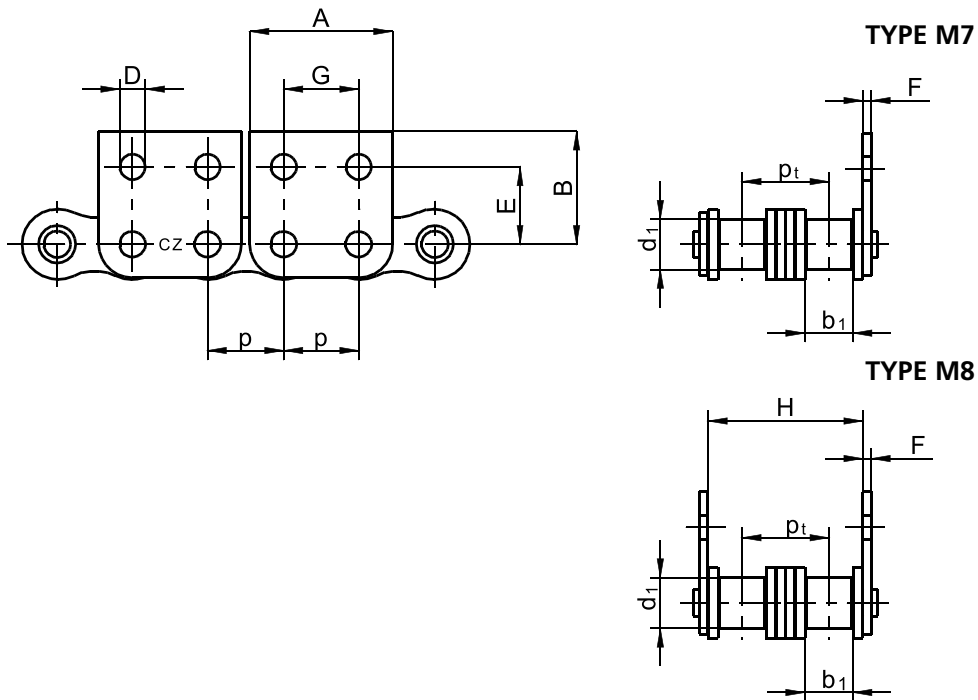

TRADE MARK ČZ	PITCH	INSIDE WIDTH	ROLLER DIAMETER	DIMENSION	DIMENSION	ATTACHMENT HOLE DIAMETER	DIMENSION	DIMENSION	DIMENSION	ATTACHMENT PLATE THICKNESS	TRANSVER. PITCH	BREAKING LOAD
	p	b1 min.	d1 max.	A	B	D	G	E	H	F	pt	FB min.
	mm	mm	mm	mm	mm	mm	mm	mm	mm	mm	mm	N
06 B-2 M7+	9,525	5,72	6,35	17,80	12,30	3,20	9,53	9,10	-	1,00	10,24	17 745
06 B-2 M8+	9,525	5,72	6,35	17,80	12,30	3,20	9,53	9,10	19,00	1,00	10,24	17 745
08 B-2 M7	12,7	7,75	8,51	24,00	19,00	4,30	12,70	13,00	-	1,50	13,92	32 655
08 B-2 M8	12,7	7,75	8,51	24,00	19,00	4,30	12,70	13,00	25,45	1,50	13,92	32 655
10 B-2 M7	15,875	9,65	10,16	28,70	24,25	5,30	15,87	16,25	-	1,50	16,59	46 726
10 B-2 M8	15,875	9,65	10,16	28,70	24,25	5,30	15,87	16,25	30,00	1,50	16,59	46 726
12 B-2 M7	19,05	11,68	12,07	34,15	30,00	6,40	19,05	21,00	-	1,80	19,46	60 690
12 B-2 M8	19,05	11,68	12,07	34,15	30,00	6,40	19,05	21,00	35,35	1,80	19,46	60 690
16 B-2 M7	25,4	17,02	15,88	45,50	39,10	8,40	25,40	30,50	-	3,00	31,88	130 000
16 B-2 M8	25,4	17,02	15,88	45,50	39,10	8,40	25,40	30,50	57,80	3,00	31,88	130 000

+ONLY WITH ONE MIDDLE PLATE

The plates M7, M8 position must be consulted with producer

DUPLEX ROLLER CHAINS WITH ATTACHMENTS K7, K8

ČZ Standard

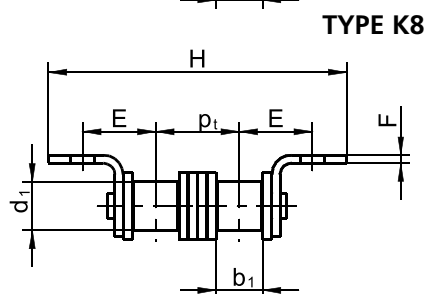
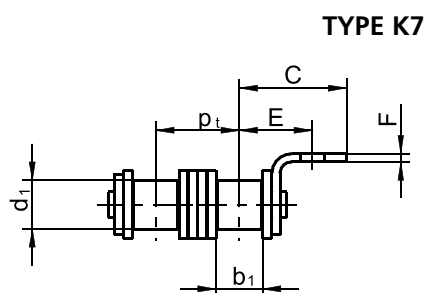
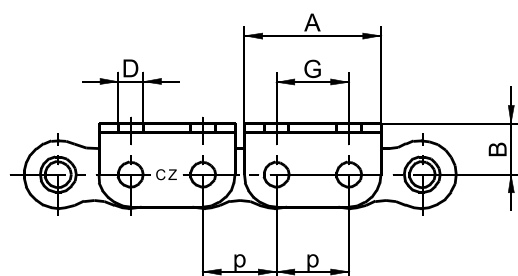

TRADE MARK ČZ	PITCH	INSIDE WIDTH	ROLLER DIAMETER	DIMENSION	DIMENSION	ATTACHMENT HOLE DIAMETER	DIMENSION	DIMENSION	DIMENSION	DIMENSION	ATTACHMENT PLATE THICKNESS	TRANSVER. PITCH	BREAKING LOAD
	p	b1 min.	d1 max.	A	B	D	C	G	E	H	F	pt	FB min.
	mm	mm	mm	mm	mm	mm	mm	mm	mm	mm	mm	mm	N
06 B-2 K7+	9,525	5,72	6,35	17,80	6,50	3,20	12,20	9,53	9,00	-	1,00	10,24	17 745
06 B-2 K8+	9,525	5,72	6,35	17,80	6,50	3,20	12,20	9,53	9,00	34,64	1,00	10,24	17 745
08 B-2 K7	12,7	7,75	8,51	24,00	8,90	4,30	18,70	12,70	12,70	-	1,50	13,92	32 655
08 B-2 K8	12,7	7,75	8,51	24,00	8,90	4,30	18,70	12,70	12,70	51,30	1,50	13,92	32 655
10 B-2 K7	15,875	9,65	10,16	28,70	10,30	5,30	23,87	15,87	15,875	-	1,50	16,59	46 726
10 B-2 K8	15,875	9,65	10,16	28,70	10,30	5,30	23,87	15,87	15,875	64,30	1,50	16,59	46 726
12 B-2 K7	19,05	11,68	12,07	34,15	13,45	6,40	28,05	19,05	19,05	-	1,80	19,46	60 690
12 B-2 K8	19,05	11,68	12,07	34,15	13,45	6,40	28,05	19,05	19,05	75,60	1,80	19,46	60 690
16 B-2 K7	25,4	17,02	15,88	45,50	20,20	8,40	37,40	25,40	28,80	-	3,00	31,88	130 000
16 B-2 K8	25,4	17,02	15,88	45,50	20,20	8,40	37,40	25,40	28,80	107,00	3,00	31,88	130 000

+ONLY WITH ONE MIDDLE PLATE

The plates K7, K8 position must be consulted with producer

TRIPLEX ROLLER CHAINS WITH ATTACHMENTS M1, M2

ČZ Standard

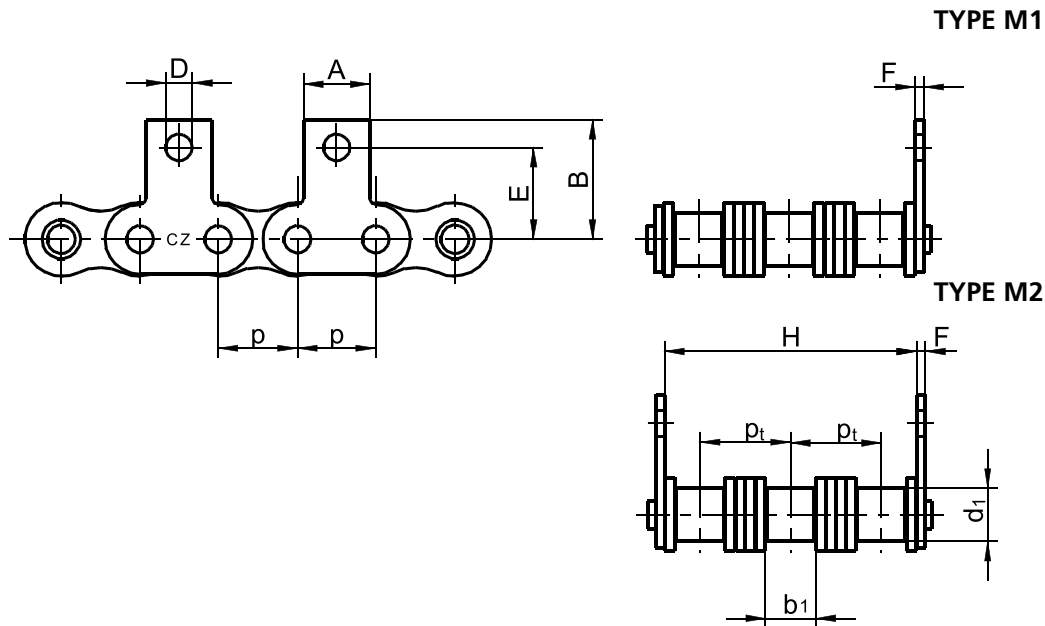

TRADE MARK ČZ	PITCH	INSIDE WIDTH	ROLLER DIAMETER	DIMENSION	DIMENSION	ATTACHMENT HOLE DIAMETER	DIMENSION	DIMENSION	ATTACHMENT PLATE THICKNESS	TRANSVER. PITCH	BREAKING LOAD
	p	b1 min.	d1 max.	A	B	D	H	E	F	pt	FB min.
	mm	mm	mm	mm	mm	mm	mm	mm	mm	mm	N
06 B-3 M1+	9,525	5,72	6,35	8,00	13,60	3,20	-	9,10	1,00	10,24	26 145
06 B-3 M2+	9,525	5,72	6,35	8,00	13,60	3,20	29,15	9,10	1,00	10,24	26 145
08 B-3 M1	12,7	7,75	8,51	11,50	19,00	4,30	-	13,00	1,40	13,92	46 725
08 B-3 M2	12,7	7,75	8,51	11,50	19,00	4,30	39,25	13,00	1,40	13,92	46 725
10 B-3 M1	15,875	9,65	10,16	14,00	24,00	5,30	-	16,00	1,50	16,59	70 035
10 B-3 M2	15,875	9,65	10,16	14,00	24,00	5,30	46,60	16,00	1,50	16,59	70 035
12 B-3 M1	19,05	11,68	12,07	17,00	30,00	6,40	-	21,00	1,80	19,46	91 035
12 B-3 M2	19,05	11,68	12,07	17,00	30,00	6,40	54,70	21,00	1,80	19,46	91 035
16 B-3 M1	25,4	17,02	15,88	24,00	39,10	8,40	-	30,50	3,00	31,88	195 000
16 B-3 M2	25,4	17,02	15,88	24,00	39,10	8,40	87,80	30,50	3,00	31,88	195 000

+MIDDLE LINK PLATE CONTAINS ONE SOLID PLATE
The plates M1, M2 position must be consulted with producer

TRIPLEX ROLLER CHAINS WITH ATTACHMENTS K1, K2

ČZ Standard

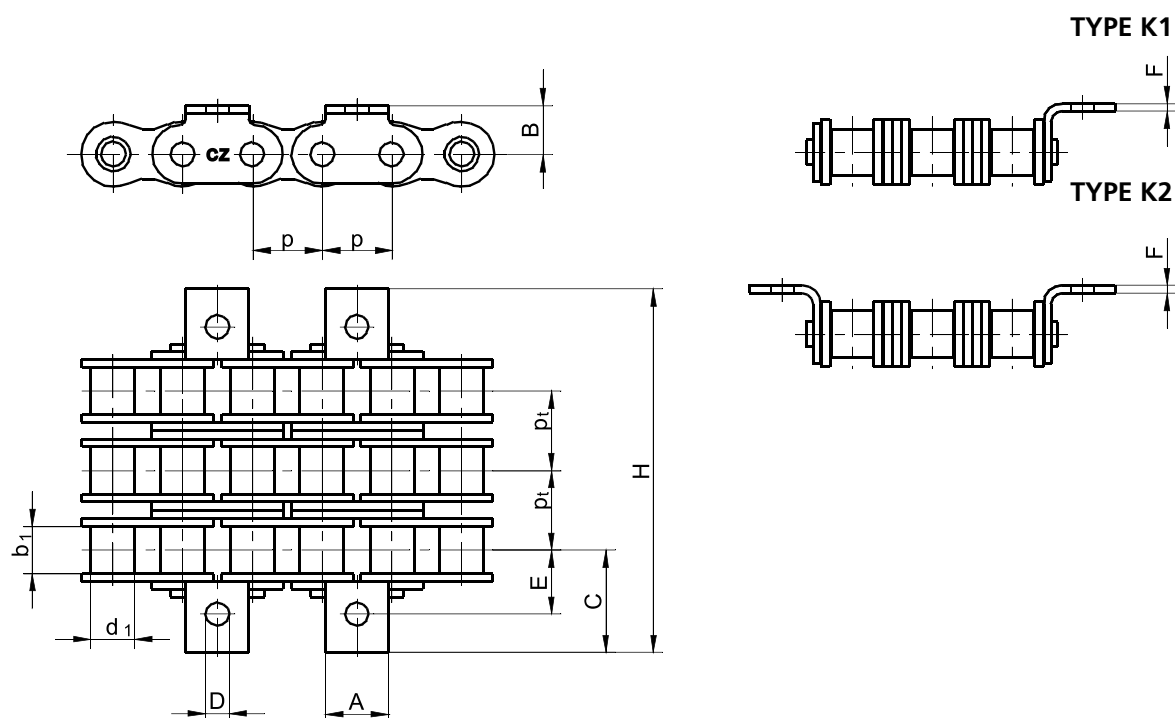

TRADE MARK ČZ	PITCH	INSIDE WIDTH	ROLLER DIAMETER	DIMENSION	DIMENSION	ATTACHMENT HOLE DIAMETER	DIMENSION	DIMENSION	DIMENSION	ATTACHMENT PLATE THICKNESS	TRANSVER. PITCH	BREAKING LOAD
	p	b1 min.	d1 max.	A	B	D	C	E	H	F	pt	FB min.
	mm	mm	mm	mm	mm	mm	mm	mm	mm	mm	mm	N
06 B-3 K1+	9,525	5,72	6,35	8,00	6,50	3,20	13,50	9,00	-	1,00	10,24	26 145
06 B-3 K2+	9,525	5,72	6,35	8,00	6,50	3,20	13,50	9,00	47,50	1,00	10,24	26 145
08 B-3 K1	12,7	7,75	8,51	11,50	8,90	4,30	18,70	12,70	-	1,40	13,92	46 725
08 B-3 K2	12,7	7,75	8,51	11,50	8,90	4,30	18,70	12,70	65,25	1,40	13,92	46 725
10 B-3 K1	15,875	9,65	10,16	14,00	10,30	5,30	23,87	15,875	-	1,50	16,59	70 035
10 B-3 K2	15,875	9,65	10,16	14,00	10,30	5,30	23,87	15,875	80,90	1,50	16,59	70 035
12 B-3 K1	19,05	11,68	12,07	17,00	13,45	6,40	28,05	19,05	-	1,80	19,46	91 035
12 B-3 K2	19,05	11,68	12,07	17,00	13,45	6,40	28,05	19,05	95,00	1,80	19,46	91 035
16 B-3 K1	25,4	17,02	15,88	24,00	20,20	8,40	36,60	28,00	-	3,00	31,88	195 000
16 B-3 K2	25,4	17,02	15,88	24,00	20,20	8,40	36,60	28,00	137,00	3,00	31,88	195 000

+MIDDLE LINK PLATE CONTAINS ONE SOLID PLATE
The plates K1, K2 position must be consulted with producer

TRIPLEX ROLLER CHAINS WITH ATTACHMENTS M7, M8

ČZ Standard

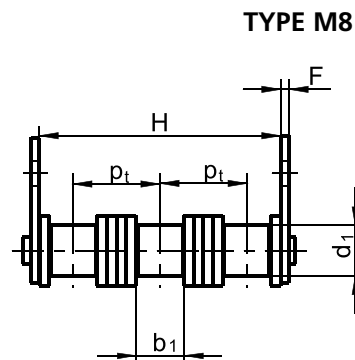
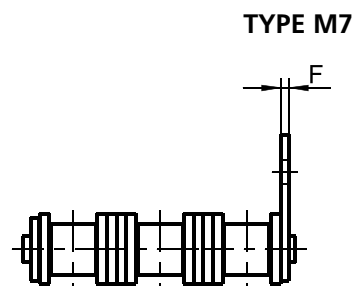
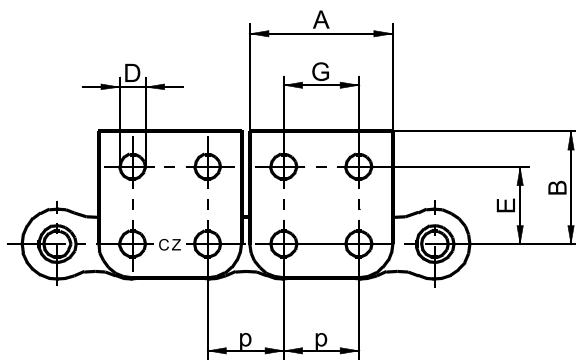

TRADE MARK ČZ	PITCH	INSIDE WIDTH	ROLLER DIAMETER	DIMENSION	DIMENSION	ATTACHMENT HOLE DIAMETER	DIMENSION	DIMENSION	DIMENSION	ATTACHMENT PLATE THICKNESS	TRANSVER. PITCH	BREAKING LOAD
	p	b_1 min.	d_1 max.	A	B	D	G	E	H	F	p_t	FB min.
	mm	mm	mm	mm	mm	mm	mm	mm	mm	mm	mm	N
08 B-3 M7	12,7	7,75	8,51	24,00	19,00	4,30	12,70	13,00	-	1,50	13,92	46 725
08 B-3 M8	12,7	7,75	8,51	24,00	19,00	4,30	12,70	13,00	39,25	1,50	13,92	46 725
10 B-3 M7	15,875	9,65	10,16	28,70	24,25	5,30	15,87	16,25	-	1,50	16,59	70 035
10 B-3 M8	15,875	9,65	10,16	28,70	24,25	5,30	15,87	16,25	46,60	1,50	16,59	70 035
12 B-3 M7	19,05	11,68	12,07	34,15	30,00	6,40	19,05	21,00	-	1,80	19,46	91 035
12 B-3 M8	19,05	11,68	12,07	34,15	30,00	6,40	19,05	21,00	54,70	1,80	19,46	91 035
16 B-3 M7	25,4	17,02	15,88	45,50	39,10	8,40	25,40	30,50	-	3,00	31,88	195 000
16 B-3 M8	25,4	17,02	15,88	45,50	39,10	8,40	25,40	30,50	89,60	3,00	31,88	195 000

The plates M7, M8 position must be consulted with producer

TRIPLEX ROLLER CHAINS WITH ATTACHMENTS K7, K8

ČZ Standard

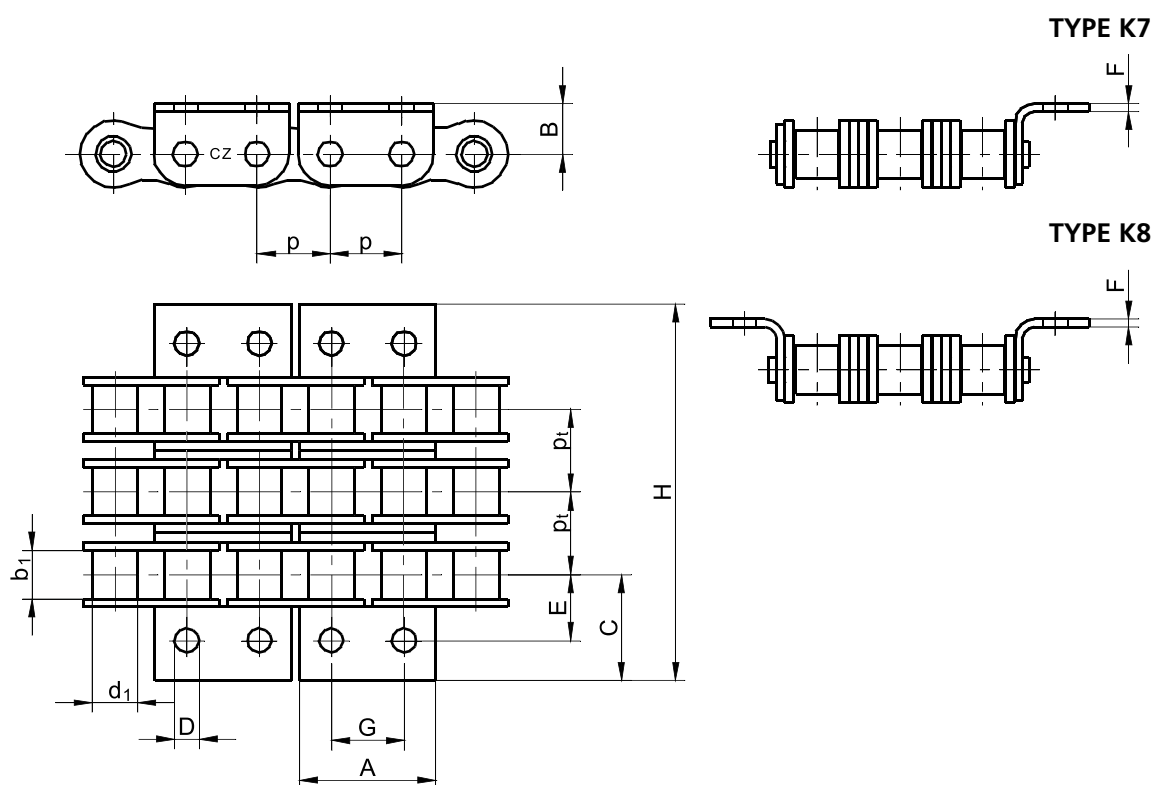

TRADE MARK CZ	PITCH	INSIDE WIDTH	ROLLER DIAMETER	DIMENSION	DIMENSION	ATTACHMENT HOLE DIAMETER	DIMENSION	DIMENSION	DIMENSION	DIMENSION	ATTACHMENT PLATE THICKNESS	TRANSVER. PITCH	BREAKING LOAD
	p	b1 min.	d1 max.	A	B	D	C	G	E	H	F	pt	FB min.
	mm	mm	mm	mm	mm	mm	mm	mm	mm	mm	mm	mm	N
08 B-3 K7	12,7	7,75	8,51	24,00	8,90	4,30	18,70	12,70	12,70	-	1,50	13,92	46 725
08 B-3 K8	12,7	7,75	8,51	24,00	8,90	4,30	18,70	12,70	12,70	65,25	50,40	13,92	46 725
10 B-3 K7	15,875	9,65	10,16	28,70	10,30	5,30	23,87	15,87	15,875	-	1,50	16,59	70 035
10 B-3 K8	15,875	9,65	10,16	28,70	10,30	5,30	23,87	15,87	15,875	80,90	1,50	16,59	70 035
12 B-3 K7	19,05	11,68	12,07	34,15	13,45	6,40	28,05	19,05	19,05	-	1,80	19,46	91 035
12 B-3 K8	19,05	11,68	12,07	34,15	13,45	6,40	28,05	19,05	19,05	95,00	1,80	19,46	91 035
16 B-3 K7	25,4	17,02	15,88	45,50	20,20	8,40	36,60	25,40	28,00	-	3,00	31,88	195 000
16 B-3 K8	25,4	17,02	15,88	45,50	20,20	8,40	36,60	25,40	28,00	137,00	3,00	31,88	195 000

The plates K7, K8 position must be consulted with producer

DOUBLE PITCH CHAINS WITH ATTACHMENTS M3, M4

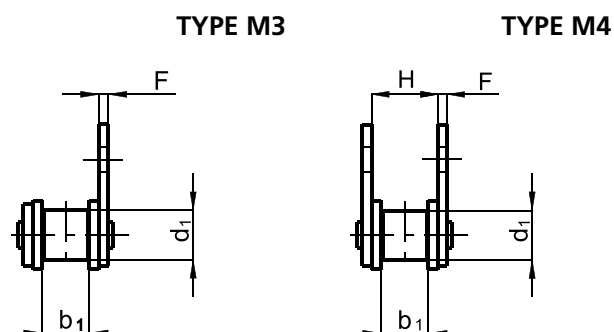
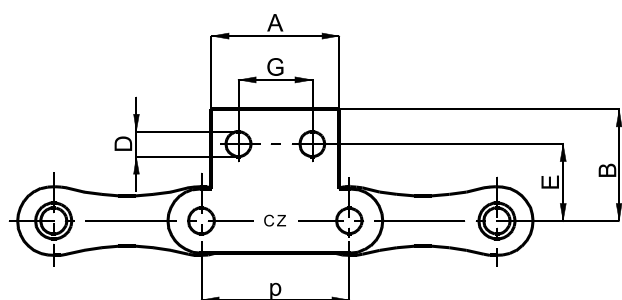

Design according to ČSN 02 3316

ČSN	PITCH	INSIDE WIDTH	ROLLER DIAMETER	DIMENSION	DIMENSION	ATTACHMENT HOLE DIAMETER	ATTACHMENT HOLES DISTANCE	DIMENSION	DIMENSION	ATTACHMENT PLATE THICKNESS	WEIGHT	BREAKING LOAD
	p	b1	d1	A	B	D	G	E	H	F	q	FB
		min.	max.									min.
	mm	mm	mm	mm	mm	mm	mm	mm	mm	mm	kg/m	N
C 208 B M3	25,4	7,75	8,51	22,00	19,20	4,30	12,70	13,20	-	1,50	0,72	18 690
C 210 B M3	31,75	9,65	10,16	28,00	25,10	5,30	15,88	17,10	-	1,50	0,63	23 310
C 212 B M3	38,1	11,68	12,07	35,00	30,60	6,40	19,05	21,60	-	1,80	0,85	30 345
C 208 B M4	25,4	7,75	8,51	22,00	19,20	4,30	12,70	13,20	11,50	1,50	0,74	18 690
C 210 B M4	31,75	9,65	10,16	28,00	25,10	5,30	15,88	17,10	13,50	1,50	0,67	23 310
C 212 B M4	38,1	11,68	12,07	35,00	30,60	6,40	19,05	21,60	15,80	1,80	0,90	30 345

The plates M3, M4 position must be consulted with producer

ČZ Standard

TRADE MARK ČZ	PITCH	INSIDE WIDTH	ROLLER DIAMETER	DIMENSION	DIMENSION	ATTACHMENT HOLE DIAMETER	ATTACHMENT HOLES DISTANCE	DIMENSION	DIMENSION	ATTACHMENT PLATE THICKNESS	WEIGHT	BREAKING LOAD
	p	b1	d1	A	B	D	G	E	H	F	q	FB
		min.	max.									min.
	mm	mm	mm	mm	mm	mm	mm	mm	mm	mm	kg/m	N
208 A M3	25,4	7,85	7,95	22,00	19,20	4,30	12,70	13,20	-	1,50	0,72	17 500
210 A M3	31,75	9,53	10,16	28,00	25,10	5,30	15,88	17,10	-	1,50	0,73	23 310
212 A M3	38,1	12,70	11,91	35,00	30,60	6,40	19,05	21,60	-	1,80	1,02	30 345
208 A M4	25,4	7,85	7,95	22,00	19,20	4,30	12,70	13,20	11,30	1,50	0,74	17 500
210 A M4	31,75	9,53	10,16	28,00	25,10	5,30	15,88	17,10	14,00	1,50	0,77	23 310
212 A M4	38,1	12,70	11,91	35,00	30,60	6,40	19,05	21,60	17,90	1,80	1,07	30 345

The plates M3, M4 position must be consulted with producer

DOUBLE PITCH CHAINS WITH ATTACHMENTS K3, K4

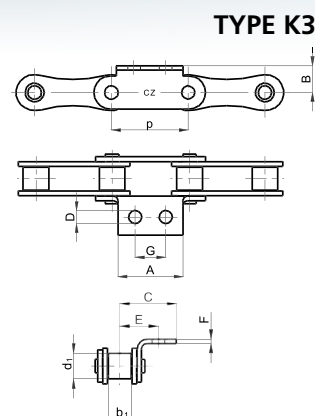
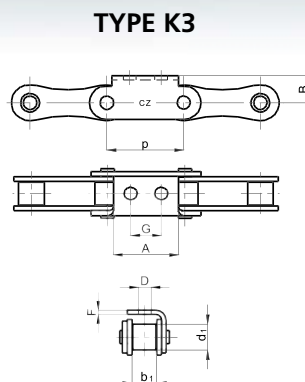
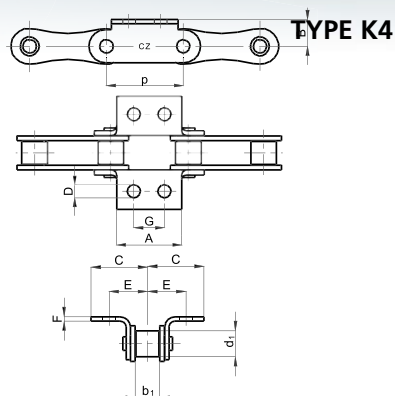

Design according to ČSN 02 3316

ČSN	PITCH	INSIDE WIDTH	ROLLER DIAMETER	DIMENSION	DIMENSION	ATTACHMENT HOLE DIAMETER	ATTACHMENT HOLES DISTANCE	DIMENSION	DIMENSION	ATTACHMENT PLATE THICKNESS	WEIGHT	BREAKING LOAD
	p	b1 min.	d1 max.	A	B	D	G	E	C	F	q	FB min.
	mm	mm	mm	mm	mm	mm	mm	mm	mm	mm	kg/m	N
C 208 B K3	25,4	7,75	8,51	22,00	9,12	4,30	12,70	12,70	18,70	1,50	0,72	18 690
C 210 B K3	31,75	9,65	10,16	28,00	11,13	5,30	15,88	15,875	23,87	1,50	0,63	23 310
C 212 B K3	38,1	11,68	12,07	35,00	14,68	6,40	19,05	19,05	27,05	1,80	0,85	30 345
C 208 B K4	25,4	7,75	8,51	22,00	9,12	4,30	12,70	12,70	18,70	1,50	0,74	18 690
C 210 B K4	31,75	9,65	10,16	28,00	11,13	5,30	15,88	15,875	23,87	1,50	0,67	23 310
C 212 B K4	38,1	11,68	12,07	35,00	14,68	6,40	19,05	19,05	27,05	1,80	0,90	30 345

The plates K3, K4 position must be consulted with producer

ČZ Standard

TRADE MARK ČZ	PITCH	INSIDE WIDTH	ROLLER DIAMETER	DIMENSION	DIMENSION	ATTACHMENT HOLE DIAMETER	DIMENSION	DIMENSION	ATTACHMENT HOLES DISTANCE	ATTACHMENT PLATE THICKNESS	WEIGHT	BREAKING LOAD
	p	b1 min.	d1 max.	A	B	D	E	C	G	F	q	FB min.
	mm	mm	mm	mm	mm	mm	mm	mm	mm	mm	kg/m	N
208 A K3	25,4	7,85	7,95	22,00	9,12	4,30	12,60	18,60	12,70	1,50	0,72	17 500
210 A K3	31,75	9,53	10,16	28,00	11,13	5,30	16,10	24,10	15,88	1,50	0,80	23 310
212 A K3	38,1	12,70	11,91	35,00	14,68	6,40	20,70	28,70	19,05	1,80	1,07	30 345
208 A K4	25,4	7,85	7,95	22,00	9,12	4,30	12,60	18,60	12,70	1,50	0,74	17 500
210 A K4	31,75	9,53	10,16	28,00	11,13	5,30	16,10	24,10	15,88	1,50	0,84	23 310
212 A K4	38,1	12,70	11,91	35,00	14,68	6,40	20,70	28,70	19,05	1,80	1,17	30 345

The plates K3, K4 position must be consulted with producer

ATTACHMENTS

ČZ Standard

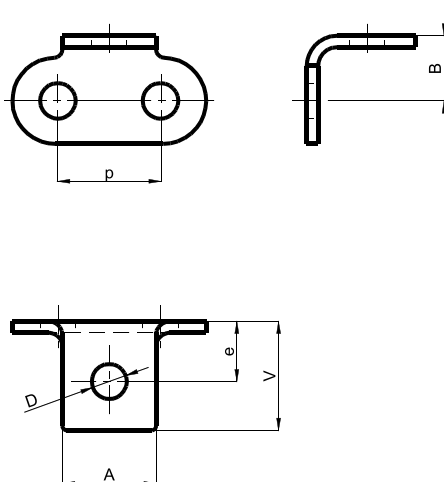

FOR CHAIN	NOMINAL PITCH	DIMENSION	DIMENSION	DIMENSION	DIMENSION	DIMENSION	PLATE
	p	A	B	D	e	V	
06 B	9,525	8,00	6,50	4,50	4,30	8,80	outer
06 B	9,525	8,00	6,50	4,50	4,30	8,80	connecting
08 B	12,7	11,50	8,90	3,30	7,00	13,00	outer
08 B	12,7	11,50	8,90	3,30	7,00	13,00	inner
08 A	12,7	11,50	8,90	4,30	8,80	14,80	inner
08 B	12,7	11,50	8,00	4,30	7,40	13,40	outer
08 B	12,7	11,50	8,90	4,30	8,30	13,00	outer
08 B	12,7	11,50	8,90	4,30	8,30	13,00	connecting
08 B	12,7	11,50	8,90	4,30	8,80	14,80	inner
08 B	12,7	11,50	8,90	4,30	8,80	13,00	outer
08 B	12,7	11,50	8,90	4,30	8,80	13,00	connecting
08 B	12,7	11,50	8,90	4,55	7,40	13,00	outer
08 B	12,7	11,50	8,90	5,00	7,00	13,00	outer
08 B	12,7	11,50	8,90	5,30	7,00	13,00	outer
08 B	12,7	11,50	8,90	5,30	7,00	13,00	connecting
08 B	12,7	11,50	8,90	6,40	7,00	13,00	outer
10 B	15,875	14,00	10,30	4,00	9,20	17,20	outer
10 B	15,875	14,00	10,10	4,30	5,80	16,80	outer

ATTACHMENTS

ČZ Standard

FOR CHAIN	NOMINAL PITCH	DIMENSION	DIMENSION	DIMENSION	DIMENSION	DIMENSION	PLATE
	p	A	B	D	e	V	
10 B	15,875	14,00	10,10	5,20	7,80	14,70	outer
10 B	15,875	14,00	10,10	5,20	7,80	14,70	connecting
10 B	15,875	14,00	10,30	5,30	10,95	18,95	inner
10 B	15,875	14,00	10,30	6,40	10,95	18,95	inner
10 B	15,875	14,00	10,30	6,40	9,20	17,20	outer
10 B	15,875	14,00	10,30	6,40	9,20	17,20	connecting
10 B	15,875	14,00	10,30	7,55	9,20	17,20	outer
For riveting nut ANCHOR MINARB BN 197 M6 for the plate thickness 0,5 – 1,6 mm							
10 B	15,875	14,00	10,30	7,55	9,20	17,20	connecting
For riveting nut ANCHOR MINARB BN 197 M6 for the plate thickness 0,5 – 1,6 mm							
10 B	15,875	14,00	11,20	5,30	8,20	16,20	outer
10 B	15,875	14,00	11,20	5,30	8,20	16,20	connecting
12 A	19,05	15,70	12,20	5,60	10,30	18,20	outer
12 B	19,05	17,00	13,45	5,64	11,10	20,10	outer
12 B	19,05	17,00	13,45	6,01	11,10	20,10	outer
12 B	19,05	17,00	13,45	6,40	9,60	20,10	outer
12 B	19,05	17,00	13,45	6,40	11,50	20,10	inner
12 B	19,05	17,00	13,45	6,40	13,10	20,10	inner
12 B	19,05	17,00	13,45	9,46	11,10	20,10	outer
For riveting nut ANCHOR MINARB BN 197 M6 for the plate thickness 1,7 - 2,4 mm							
12 B	19,05	17,00	13,45	9,46	11,10	20,10	connecting
For riveting nut ANCHOR MINARB BN 197 M6 for the plate thickness 1,7 - 2,4 mm							
16 B	25,4	24,00	17,00	8,40	16,20	25,60	outer
16 B	25,4	24,00	17,00	8,40	16,20	25,60	connecting
16 B	25,4	24,00	18,00	8,40	16,20	24,60	outer
16 B	25,4	24,00	18,00	8,40	16,20	24,60	connecting
16 B	25,4	24,00	18,00	9,00	16,20	24,60	outer
16 B	25,4	24,00	18,00	9,00	16,20	24,60	connecting
16 B	25,4	24,00	20,20	8,40	13,70	24,60	outer
16 B	25,4	24,00	20,20	8,40	13,70	24,60	connecting
16 B	25,4	24,00	20,20	10,20	16,00	24,60	outer
16 B	25,4	24,00	20,20	10,20	16,00	24,60	connecting

ATTACHMENTS

ČZ Standard

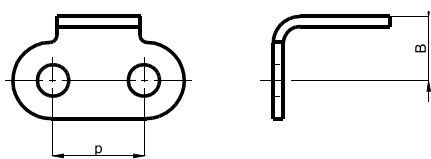

FOR CHAIN	NOMINAL PITCH	DIMENSION	DIMENSION	DIMENSION	PLATE
	p	A	B	V	
08 B	12,70	11,50	8,90	13,00	outer
08 B	12,70	11,50	8,90	13,00	connecting
12 B	19,05	17,00	13,45	20,10	outer

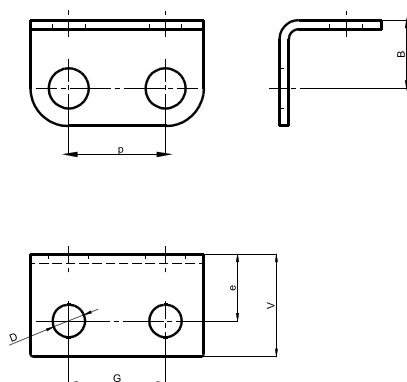
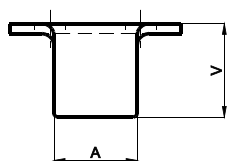

FOR CHAIN	NOMINAL PITCH	DIMENSION	DIMENSION	DIMENSION	DIMENSION	DIMENSION	PLATE
	p	B	D	e	G	V	
08 B	12,7	8,50	4,30	8,10	12,70	13,30	outer
08 B	12,7	8,50	4,30	9,90	12,70	13,30	inner
08 B	12,7	8,90	4,30	13,10	12,70	19,10	outer
10 B	15,875	10,30	5,30	10,95	15,88	17,45	outer
10 B	15,875	10,30	5,30	10,95	15,88	17,45	connecting
12 B	19,05	11,80	6,40	9,60	19,05	17,00	outer
12 B	19,05	11,80	6,40	13,60	19,05	22,60	outer
12 B	19,05	13,45	5,30	11,10	19,05	17,30	outer
12 B	19,05	13,45	6,40	13,10	19,05	20,10	inner

ATTACHMENTS

ČZ Standard

FOR CHAIN	NOMINAL PITCH	DIMENSION	DIMENSION	DIMENSION	DIMENSION	PLATE
	p	A	D	E	J	
06 B	9,525	8,00	4,50	9,10	13,60	outer
06 B	9,525	8,00	4,50	9,10	13,60	connecting
08 B	12,7	11,50	4,30	13,00	20,60	inner
08 B	12,7	11,50	4,30	14,30	19,00	outer
08 B	12,7	11,50	4,37	14,60	19,00	outer
08 B	12,7	11,50	4,37	14,60	19,00	connecting
08 B	12,7	11,50	4,55	13,00	19,00	outer
08 B	12,7	11,50	4,55	13,40	19,00	outer
08 B	12,7	11,50	5,00	13,00	19,00	outer
08 B	12,7	11,50	6,40	13,00	19,00	outer
08 B	12,7	11,50	6,40	13,00	19,00	connecting
10 B	15,875	14,00	4,30	13,00	24,00	outer
10 B	15,875	14,00	4,30	13,00	24,00	connecting
10 B	15,875	14,00	4,99	16,70	19,00	outer
10 B	15,875	14,00	4,99	16,70	19,00	connecting
10 B	15,875	14,00	5,20	15,00	21,90	outer
10 B	15,875	14,00	5,30	16,00	25,55	inner
12 A	19,05	15,70	5,60	18,25	26,15	outer
12 A	19,05	15,70	5,60	18,25	26,15	inner
12 B	19,05	17,00	5,64	21,00	30,00	outer
12 B	19,05	17,00	6,40	19,50	30,00	outer
12 B	19,05	17,00	6,40	21,00	30,00	inner
12 B	19,05	17,00	6,40	21,40	30,00	inner
12 B	19,05	17,00	6,40	19,50	30,00	connecting
16 B	25,4	24,00	8,40	27,50	36,90	outer
16 B	25,4	24,00	8,40	27,50	36,90	connecting
16 B	25,4	24,00	8,40	28,50	36,90	outer
16 B	25,4	24,00	8,40	28,50	36,90	connecting
16 B	25,4	24,00	8,40	28,20	39,10	outer
16 B	25,4	24,00	8,40	28,20	39,10	connecting
16 B	25,4	24,00	9,20	30,50	39,10	outer
16 B	25,4	24,00	9,20	30,50	39,10	connecting

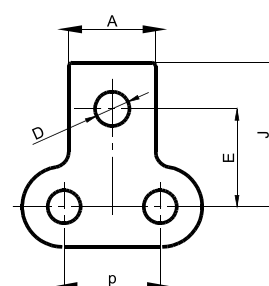

ATTACHMENTS

ČZ Standard

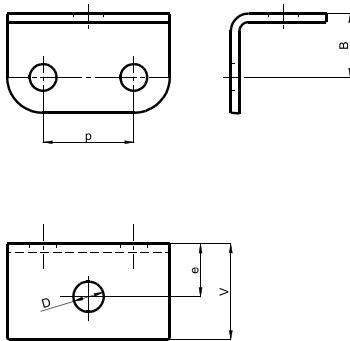

FOR CHAIN	NOMINAL PITCH	DIMENSION	DIMENSION	DIMENSION	DIMENSION	PLATE
	p	B	D	e	V	
08 B	12,7	8,90	6,40	8,30	13,00	outer
08 B	12,7	8,90	6,40	8,30	13,00	connecting
10 B	15,875	10,30	5,30	9,20	17,20	outer
12 B	19,05	13,45	6,40	11,10	20,10	outer
12 B	19,05	13,45	6,40	11,10	20,10	connecting
16 B	25,4	20,20	8,20	16,00	24,60	outer

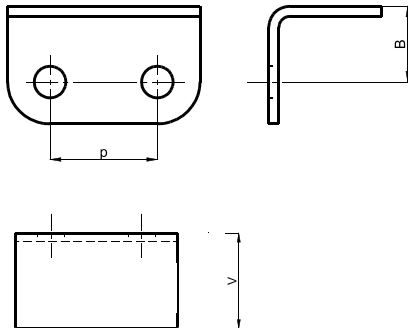

FOR CHAIN	NOMINAL PITCH	DIMENSION	DIMENSION	PLATE
	p	B	V	
06 B	9,525	6,50	7,90	outer
08 B	12,7	8,90	13,00	outer
08 B	12,7	8,90	13,00	connecting
08 B	12,7	8,90	19,10	outer
12 B	19,05	13,45	20,10	outer

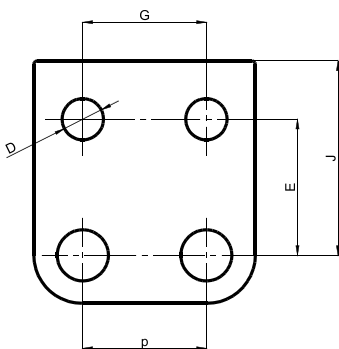

FOR CHAIN	NOMINAL PITCH	DIMENSION	DIMENSION	DIMENSION	DIMENSION	PLATE
	p	D	E	G	J	
06 B	9,525	3,20	9,10	9,41	12,30	outer
06 B	9,525	3,20	9,10	9,41	12,30	connecting
08 B	12,7	4,30	13,80	12,70	19,00	outer
08 B	12,7	4,30	15,60	12,70	19,00	inner
10 B	15,875	5,30	16,25	15,87	24,25	inner
10 B	15,875	5,30	17,75	15,88	24,25	outer
10 B	15,875	5,30	17,75	15,88	24,25	connecting
12 B	19,05	5,30	21,00	19,05	27,20	outer
12 B	19,05	5,64	21,00	19,05	30,00	outer
12 B	19,05	6,40	21,00	19,05	30,00	inner
12 B	19,05	6,40	23,00	19,05	30,00	inner

ATTACHMENTS

ČZ Standard

FOR CHAIN	NOMINAL PITCH	DIMENSION	DIMENSION	DIMENSION	PLATE
	p	D	E	J	
08 B	12,7	4,30	17,00	23,00	outer
08 B	12,7	4,30	17,00	25,10	outer
08 B	12,7	6,40	14,30	19,00	outer
10 B	15,875	5,30	16,25	24,25	outer
16 B	25,4	8,20	30,50	39,10	outer

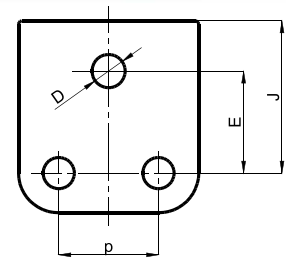

FOR CHAIN	NOMINAL PITCH	DIMENSION	PLATE
	p	J	
06 B	9,525	8,10	outer
08 B	12,7	19,00	outer
08 B	12,7	25,10	outer
10 B	15,875	24,25	outer
10 B	15,875	24,25	connecting
10 B	15,875	33,50	outer
12 B	19,05	14,00	outer
12 B	19,05	14,00	inner
12 B	19,05	14,00	connecting
12 B	19,05	24,30	inner
16 B	25,4	39,10	outer

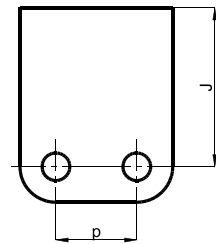

FOR CHAIN	NOMINAL PITCH	DIMENSION	DIMENSION	DIMENSION	DIMENSION	DIMENSION	PLATE
	p	A	B	D	e	V	
208 B	25,4	22,00	8,50	4,30	8,10	13,60	outer
208 B	25,4	22,00	9,12	4,30	7,00	13,00	outer
208 B	25,4	22,00	9,12	5,30	7,00	13,00	outer
210 B	31,75	28,00	11,13	4,30	9,20	17,20	outer
210 B	31,75	28,00	11,13	5,30	9,20	17,20	outer
212 B	38,10	35,00	14,68	6,40	11,15	19,15	outer

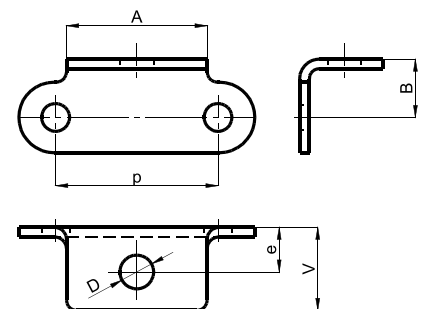

FOR CHAIN	NOMINAL PITCH	DIMENSION	DIMENSION	DIMENSION	DIMENSION	PLATE
	p	A	D	E	J	
208 B	25,4	22,00	4,30	13,70	19,20	outer
208 B	25,4	22,00	4,30	13,20	19,20	outer
208 B	25,4	22,00	5,30	13,20	19,20	outer
212 B	38,1	35,00	6,40	21,90	29,90	outer

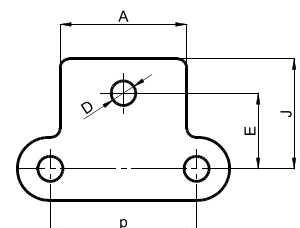

ATTACHMENTS

ČZ Standard

1/2"x1/4" MOFA, 1/2"x3/16" MOFA outer, connecting

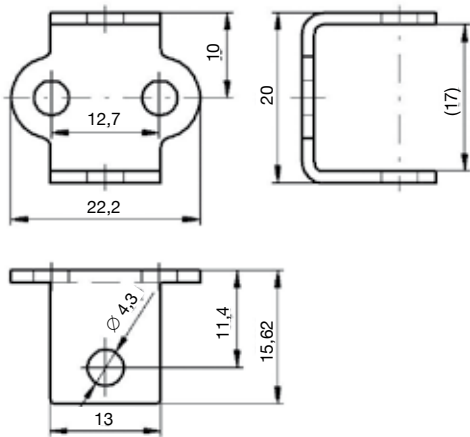

1/2"x3/16" VD, 1/2"x3/16" MOFA, 1/2"x1/4" MOFA outer

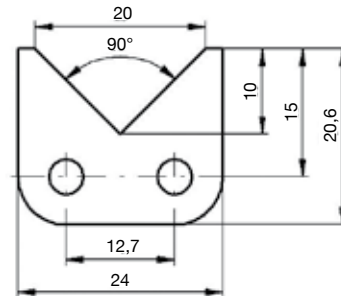

1/2"x3/16" Mofa outer

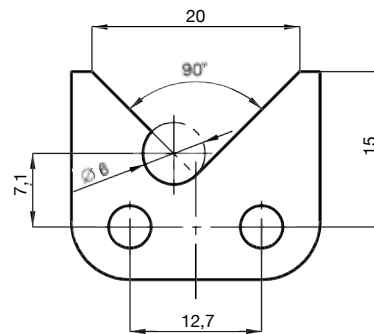

1/2"x3/16" Velo outer, inner

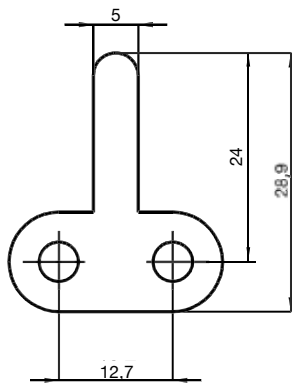

06 A, 06 B inner

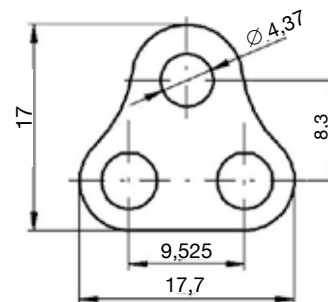

1/2"x3/16" MOFA, 1/2"x1/4" MOFA outer

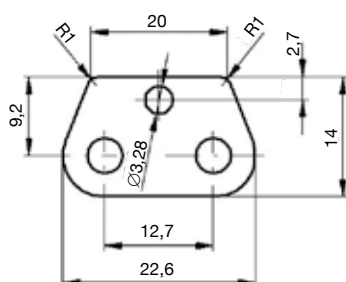

ATTACHMENTS

ČZ Standard

06 C outer, inner and connecting

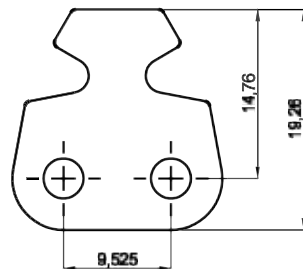

06 B outer, inner and connecting

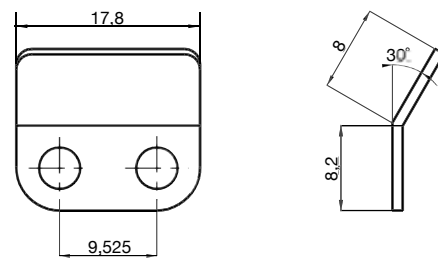

08B outer, inner and connecting

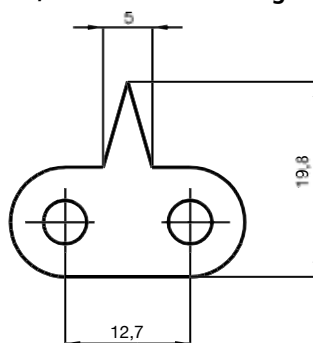

08B Outer

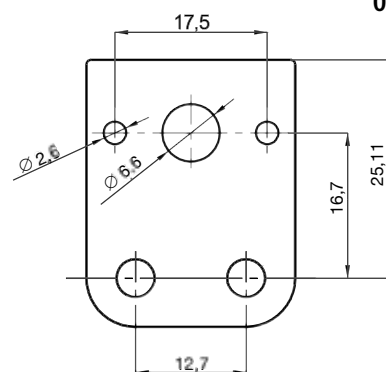

Straight pointed end or grinded under 15° angle taper can be oriented inside or outside of the chain

081 Outer

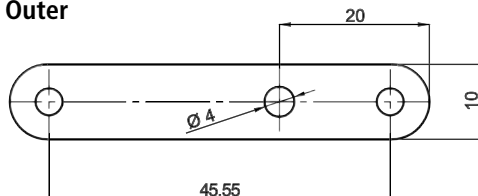

082 Outer

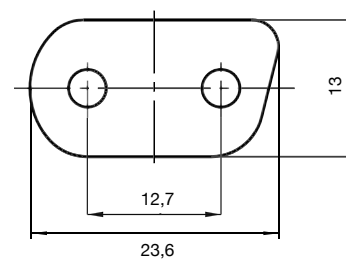

08 B outer, inner, connecting

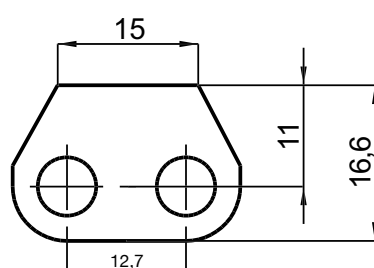

08 B outer, inner, connecting

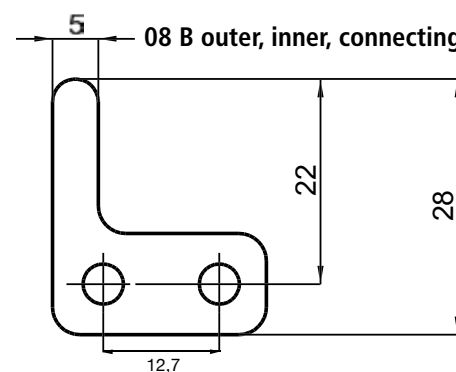



ATTACHMENTS

ČZ Standard

08 B outer

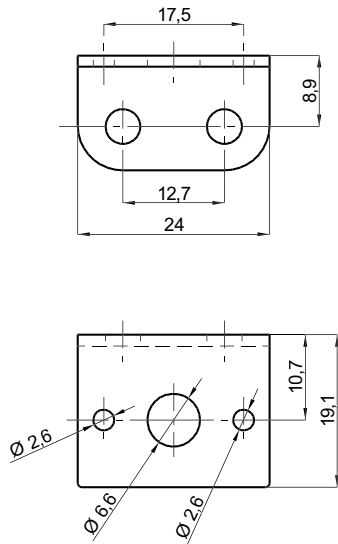

08 B outer, connecting

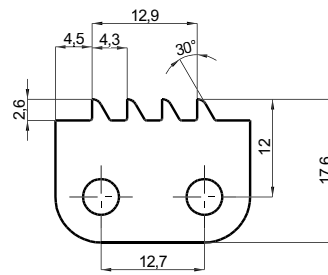

08 B a 08 A inner

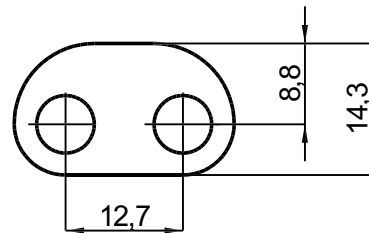

08 B a 08 A outer, inner, connecting

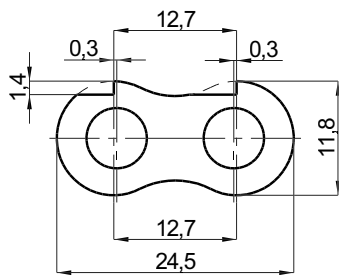

08 B outer

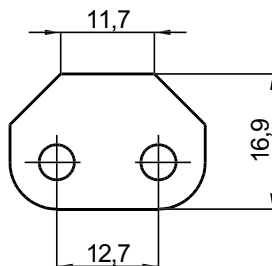

08 B, 086 outer, connecting

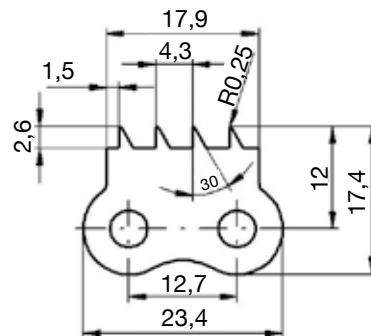

ATTACHMENTS

ČZ Standard

08 B, 086 outer

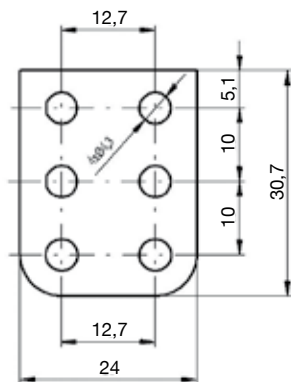

08 B a 08 A outer, inner, connecting

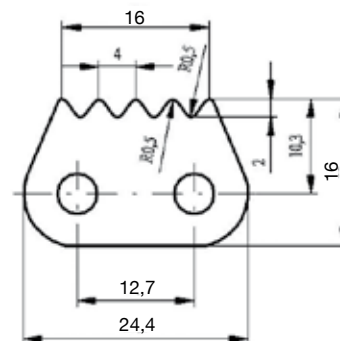

08 B, 086 outer, connecting

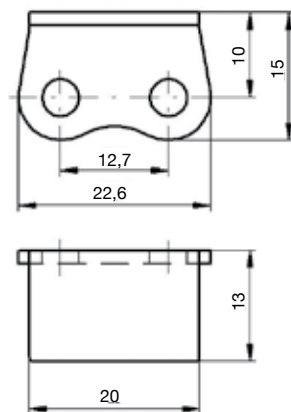

08 B a 086 outer, inner, connecting

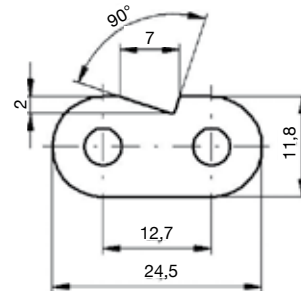

08 B outer, inner, connecting

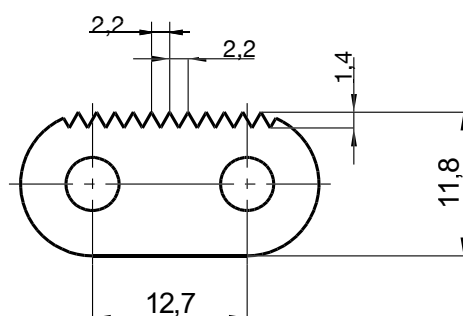

08 B, 086 outer, connecting

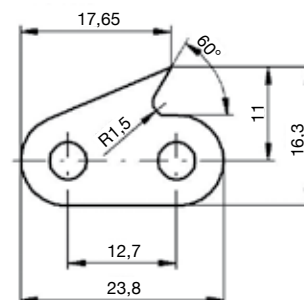

Apex is grinded



ATTACHMENTS

ČZ Standard

08 B, 086 outer

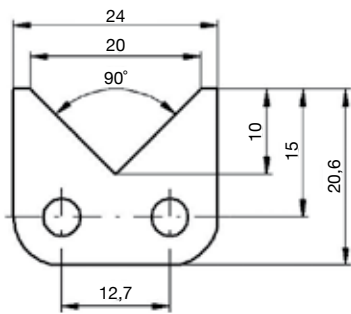

081, 082, 1/2"x3/16" VELO outer

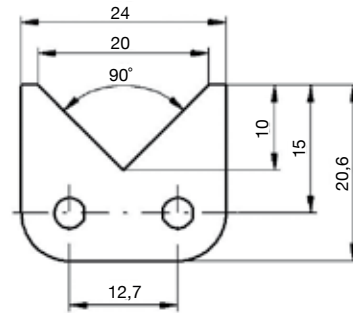

081, 082, 1/2"x3/16" VELO outer

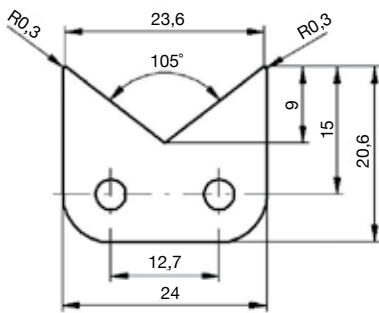

10 B, 101 outer

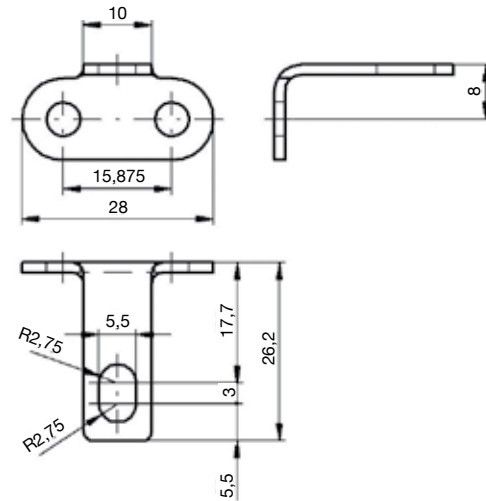

10 B outer

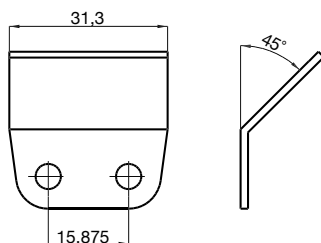

10 B outer

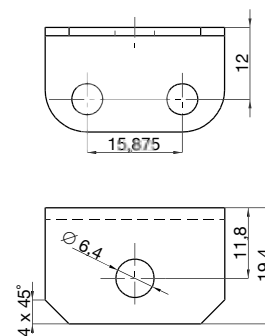

ATTACHMENTS

ČZ Standard

10 B outer

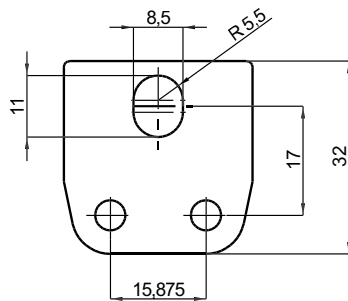

10 B inner

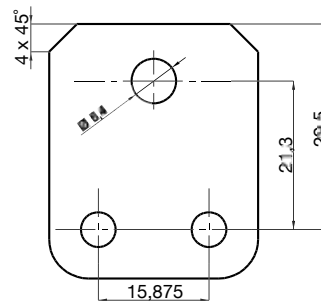

10 B inner

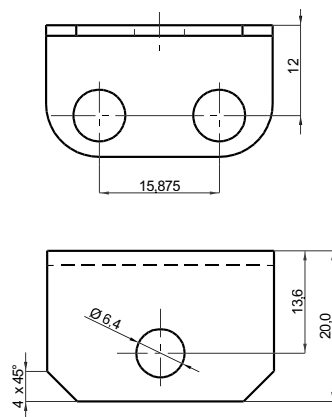

10 B outer

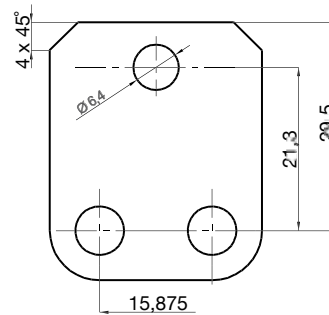

08 B, 086 outer, connecting

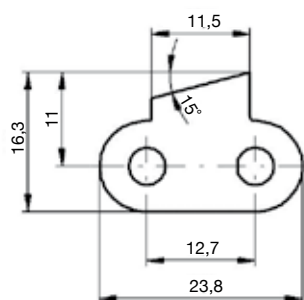

10 B outer, inner and connecting

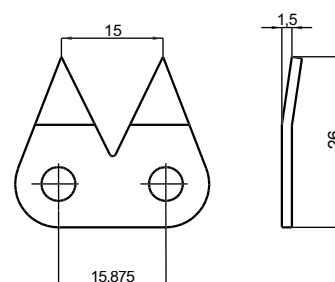

ATTACHMENTS

ČZ Standard

10 B outer

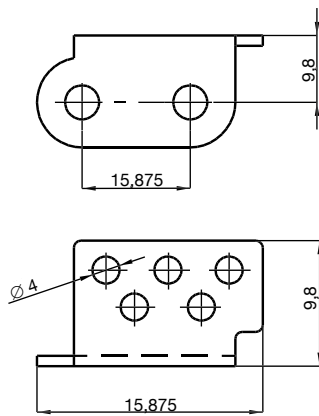

12 B a 12 A outer, inner and connecting

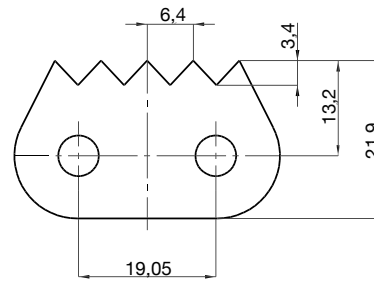

10 B outer, inner and connecting

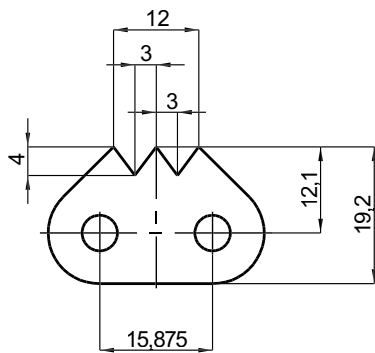

12 B outer

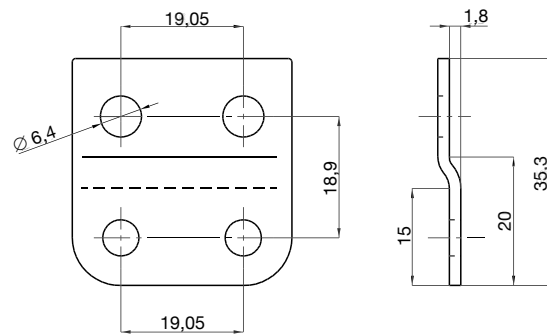

12 B outer

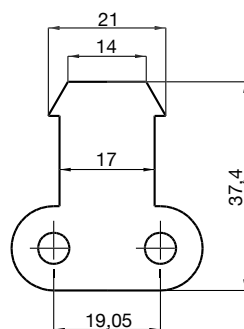

12B outer

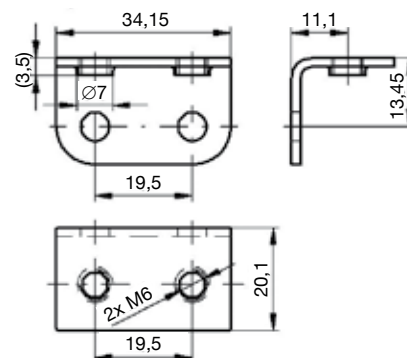

ATTACHMENTS

ČZ Standard

12 B outer right and left

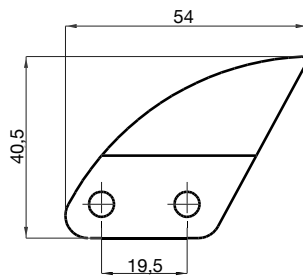

12B inner

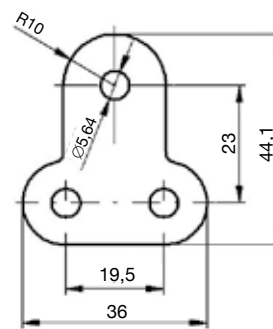

12 B outer

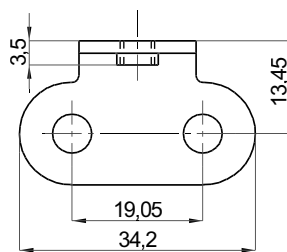

12 B

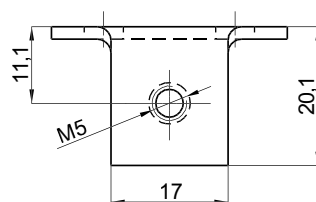
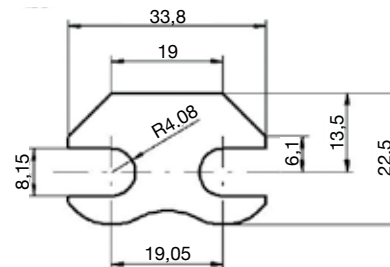

16 B outer

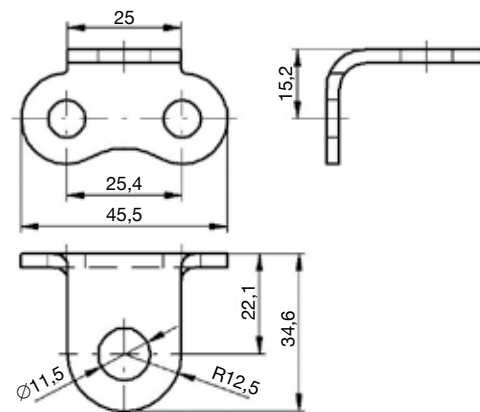

12 B a 12 A outer, inner and connecting

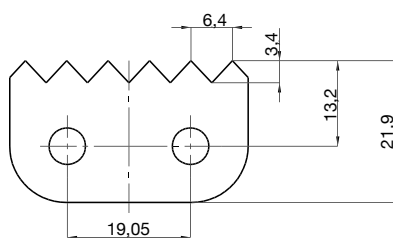

16 B outer

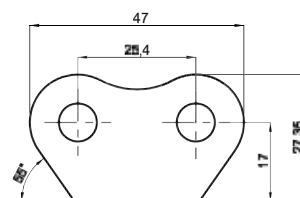

Straight or grinded apex under $\angle 15^\circ$

ATTACHMENTS

ČZ Standard

16 B outer

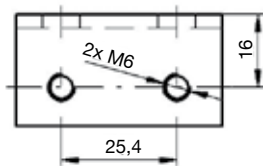
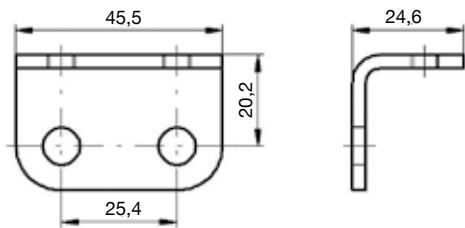

16 B outer, connecting

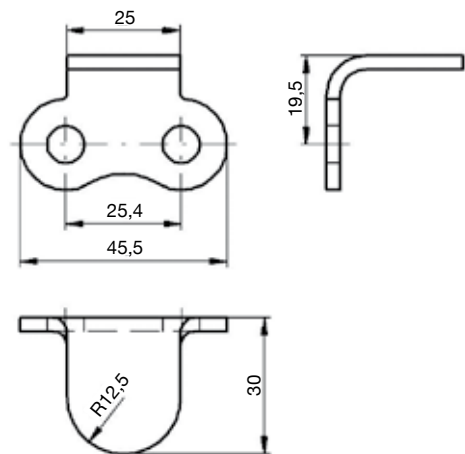

16 B outer, inner, connecting

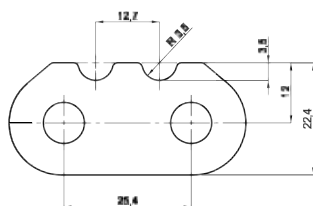

16 B outer, inner, connecting

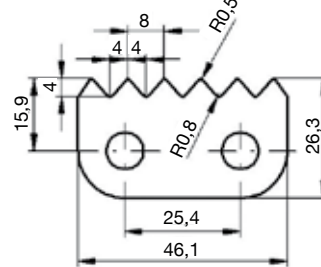

212 A outer, connecting

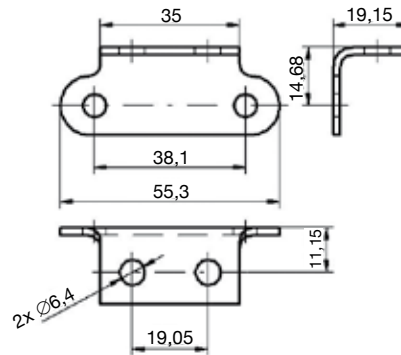

C 212 B outer, connecting

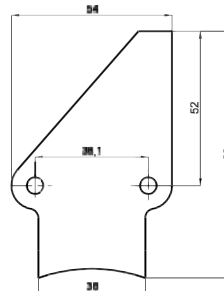

C 212 B outer, right, left connecting right

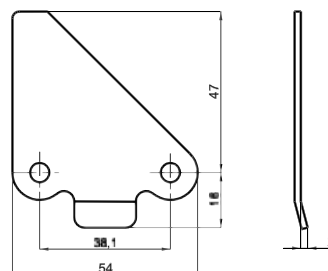



ROLLER CHAINS WITH EXTENDED AND HOLLOW PINS

ČZ Standard

Simplex roller and bush chains with one side extended pin	63–65
Simplex roller chains with both side extended pins	66–67
Duplex roller chains with one side extended pins	68
Triplex roller chains with one side extended pins	69
Simplex roller chains with extended shouldered pins	70–71
Duplex roller chains with extended shouldered pins	72
Special extended pins	73
Simplex roller chains with hollow pins	74–75
Duplex roller chains with hollow pins	76–77
Simplex roller chains with extended bars	78
Roller chains with rotary bushes	79
Conveyor chain belts	80

Hollow pin chains build another group of conveyor chains.

These chains are of standard design only the solid pin is replaced with hollow pins (the same shape like bushes).

This solution acts as an easy and simple application of attachments in the shape of bars, screws, etc.

The picture shows the design and possible application.

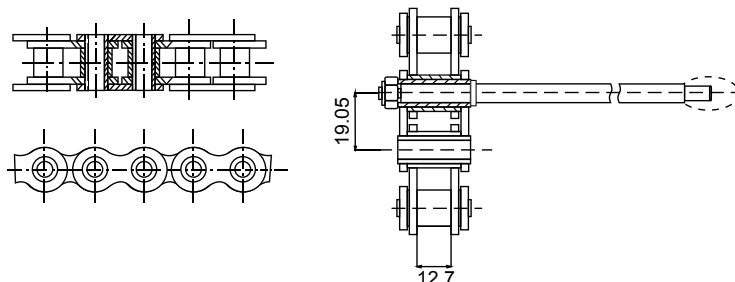

Conveyor chains with hollow pins and examples of application

Simple chains with extended pins mainly use pins from duplex or triplex chains but the pin length, combination and positioning in the chain is discretionary.

We also produce pin modifications that have various attachment diameters, shoulders, holders, threads, etc.

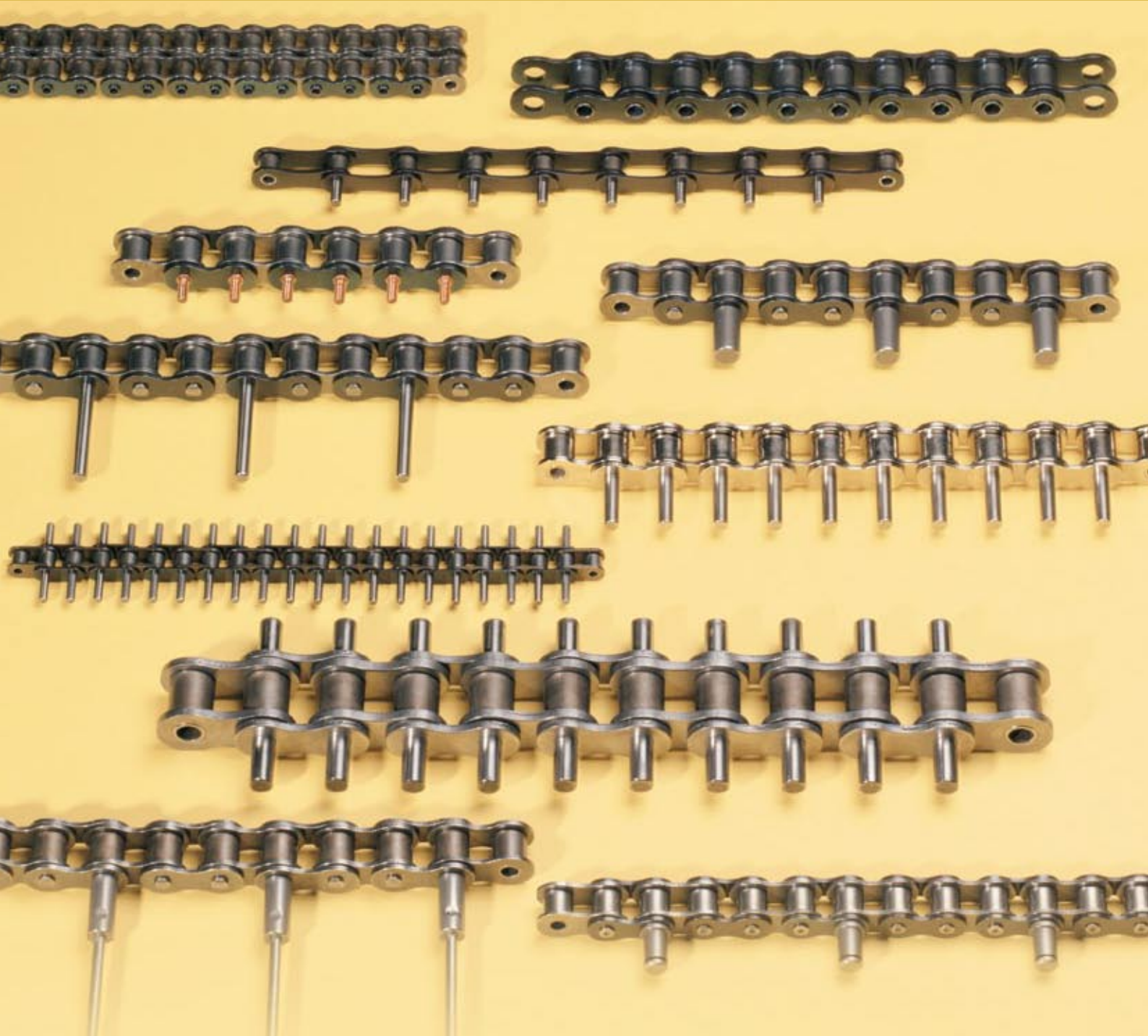

EXTENDED AND HOLLOW PIN CHAINS

- are used for direct transport of goods or can be also used in combination with various accessories

Applications: conveyors for farming, chemical, electrotechnical, printing, dairy, bake and packaging industry

SIMPLEX ROLLER AND BUSH CHAINS WITH ONE SIDE EXTENDED PIN

ČZ Standard

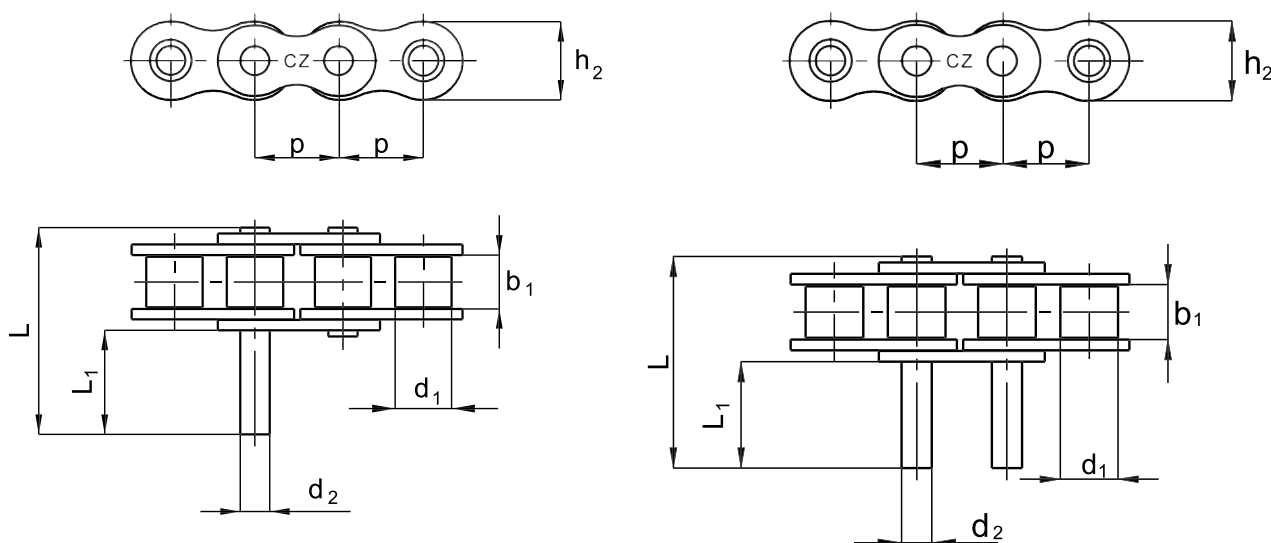

TRADE MARK ČZ	PITCH	INSIDE WIDTH	ROLLER DIAMETER (BUSH)	PIN DIAMETER	PIN LENGHT	PIN EXTENSION	INNER PLATE WIDTH
	p	b1 min.	d1 max.	d2 max.	L max.	L1 max.	h2 max.
	mm	mm	mm	mm	mm	mm	mm
05 B-1	8,0	3,00	5,00	2,31	10,25	3,00	7,20
05 B-1	8,0	3,00	5,00	2,31	12,25	5,00	7,20
05 B-1	8,0	3,00	5,00	2,31	24,00	16,80	7,20
06 B-1*	9,525	5,72	6,35	3,28	14,80	3,00	8,20
06 B-1*	9,525	5,72	6,35	3,28	16,80	5,00	8,20
06 B-1*	9,525	5,72	6,35	3,28	21,75	10,00	8,20
06 B-1*	9,525	5,72	6,35	3,28	22,65	10,90	8,20
06 B-1*	9,525	5,72	6,35	3,28	23,70	12,00	8,20
06 B-1*	9,525	5,72	6,35	3,28	32,90	21,25	8,20
06 C-1*	9,525	4,77	5,08 BUSH	3,58	32,60	21,50	8,20
081	12,7	3,30	7,75	3,66	13,60	4,85	9,90
081	12,7	3,30	7,75	3,66	20,00	11,20	9,90
081	12,7	3,30	7,75	3,66	25,50	16,50	10,00
081	12,7	3,30	7,75	3,66	31,00	22,00	10,00
1/2"x3/16" VELO	12,7	4,88	7,75	3,66	16,50	6,00	9,90
1/2"x3/16" VELO	12,7	4,88	7,75	3,66	20,50	10,00	9,90

*Only with straight plates

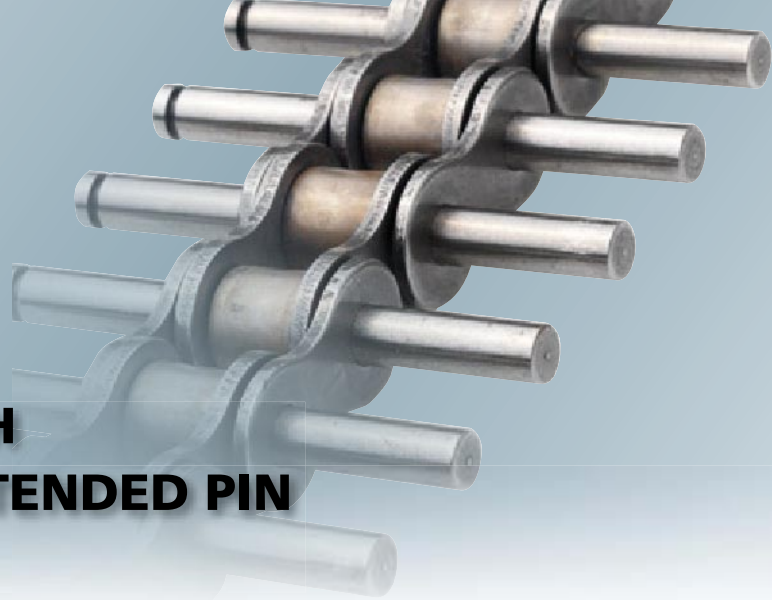

SIMPLEX ROLLER AND BUSH CHAINS WITH ONE SIDE EXTENDED PIN

ČZ Standard

TRADE MARK ČZ	PITCH	INSIDE WIDTH	ROLLER DIAMETER (BUSH)	PIN DIAMETER	PIN LENGTH	PIN EXTENSION	INNER PLATE WIDTH
	p	b1 min.	d1 max.	d2 max.	L max.	L1 max.	h2 max.
	mm	mm	mm	mm	mm	mm	mm
1/2"x3/16" VELO	12,7	4,88	7,75	3,66	35,50	25,00	9,90
062 C-1	9,525	9,52	6,00 BUSH	4,18	31,40	15,25	9,25
086	12,7	5,21	8,51	4,45	30,45	17,50	11,80
08 B-1	12,7	7,75	8,51	4,45	18,55	3,00	11,80
08 B-1	12,7	7,75	8,51	4,45	20,60	5,00	11,80
08 B-1	12,7	7,75	8,51	4,45	21,60	6,00	11,80
08 B-1	12,7	7,75	8,51	4,45	23,30	7,80	11,80
08 B-1	12,7	7,75	8,51	4,45	23,75	8,20	11,80
08 B-1	12,7	7,75	8,51	4,45	24,00	8,50	11,80
08 B-1	12,7	7,75	8,51	4,45	25,00	9,50	11,80
08 B-1	12,7	7,75	8,51	4,45	27,00	11,50	11,80
08 B-1	12,7	7,75	8,51	4,45	28,80	13,20	11,80
08 B-1	12,7	7,75	8,51	4,45	30,45	14,90	11,80
08 B-1	12,7	7,75	8,51	4,45	32,30	16,80	11,80
08 B-1	12,7	7,75	8,51	4,45	33,05	17,50	11,80
08 B-1	12,7	7,75	8,51	4,45	34,00	18,40	11,80
08 B-1	12,7	7,75	8,51	4,45	35,55	20,00	11,80
08 B-1	12,7	7,75	8,51	4,45	40,55	25,00	11,80
08 B-1	12,7	7,75	8,51	4,45	44,25	28,70	11,80
08 B-1	12,7	7,75	8,51	4,45	46,50	31,00	11,80
08 B-1	12,7	7,75	8,51	4,45	57,50	42,00	11,80
10 A-1	15,875	9,53	10,16	5,08	26,20	7,40	14,50
10 A-1	15,875	9,53	10,16	5,08	28,00	9,00	14,50
10 B-1	15,875	9,65	10,16	5,08	20,20	2,50	14,50
10 B-1	15,875	9,65	10,16	5,08	25,70	8,00	14,50
10 B-1	15,875	9,65	10,16	5,08	26,10	8,40	14,50
10 B-1	15,875	9,65	10,16	5,08	29,80	12,00	14,50
10 B-1	15,875	9,65	10,16	5,08	30,00	12,25	14,50
10 B-1	15,875	9,65	10,16	5,08	31,00	13,30	14,50
10 B-1	15,875	9,65	10,16	5,08	35,30	17,60	14,50
10 B-1	15,875	9,65	10,16	5,08	37,80	20,00	14,50
10 B-1	15,875	9,65	10,16	5,08	40,00	22,30	14,50

SIMPLEX ROLLER AND BUSH CHAINS WITH ONE SIDE EXTENDED PIN

ČZ Standard

TRADE MARK ČZ	PITCH	INSIDE WIDTH	ROLLER DIAMETER (BUSH)	PIN DIAMETER	PIN LENGTH	PIN EXTENSION	INNER PLATE WIDTH
	p	b1 min.	d1 max.	d2 max.	L max.	L1 max.	h2 max.
	mm	mm	mm	mm	mm	mm	mm
10 B-1	15,875	9,65	10,16	5,08	42,70	32,00	14,50
10 B-1	15,875	9,65	10,16	5,08	51,90	34,15	14,50
10 B-1	15,875	9,65	10,16	5,08	68,60	50,80	14,50
10 B-1	15,875	9,65	10,16	5,08	85,20	67,40	14,50
12 B-1	19,05	11,68	12,07	5,72	24,60	3,70	16,10
12 B-1	19,05	11,68	12,07	5,72	31,00	10,00	16,10
12 B-1	19,05	11,68	12,07	5,72	41,75	20,80	16,10
12 B-1	19,05	11,68	12,07	5,72	42,15	21,15	16,10
12 B-1	19,05	11,68	12,07	5,72	61,25	40,40	16,10
12 A-1	19,05	12,70	11,91	5,94	38,60	14,50	17,70
12 A-1	19,05	12,70	11,91	5,94	48,20	24,10	17,70
12 A-1	19,05	12,70	11,91	5,94	54,15	30,00	17,70
12 A-1 H	19,05	12,70	11,90	5,94	48,20	20,60	17,70
12 B-1 STRONG	19,05	11,68	12,07	6,10	63,60	40,40	17,70
16 B-1	25,4	17,02	15,88	8,28	53,50	20,00	21,00
16 B-1	25,4	17,02	15,88	8,28	58,65	25,00	21,00
16 B-1	25,4	17,02	15,88	8,28	63,70	30,00	21,00
16 B-1	25,4	17,02	15,88	8,28	65,20	31,50	21,00
16 B-1	25,4	17,02	15,88	8,28	67,30	33,60	21,00
16 B-1	25,4	17,02	15,88	8,28	73,65	40,00	21,00
16 B-1	25,4	17,02	15,88	8,28	90,70	57,00	21,00
16 B-1	25,4	17,02	15,88	8,28	99,10	65,40	21,00
208 B	25,4	7,75	8,51	4,45	25,50	10,00	12,00
208 B	25,4	7,75	8,51	4,45	30,45	14,90	12,00
208 B	25,4	7,75	8,51	4,45	44,25	28,70	12,00
210 B	31,75	9,65	10,16	5,08	35,30	17,60	14,40
210 B	31,75	9,65	10,16	5,08	51,90	34,15	14,40
212 B	38,1	11,68	12,07	5,72	28,00	7,00	16,40
212 B	38,1	11,68	12,07	5,72	41,75	20,80	16,40
212 B	38,1	11,68	12,07	5,72	61,25	40,40	16,40
212 A	38,1	12,70	11,91	5,94	35,10	11,00	16,40

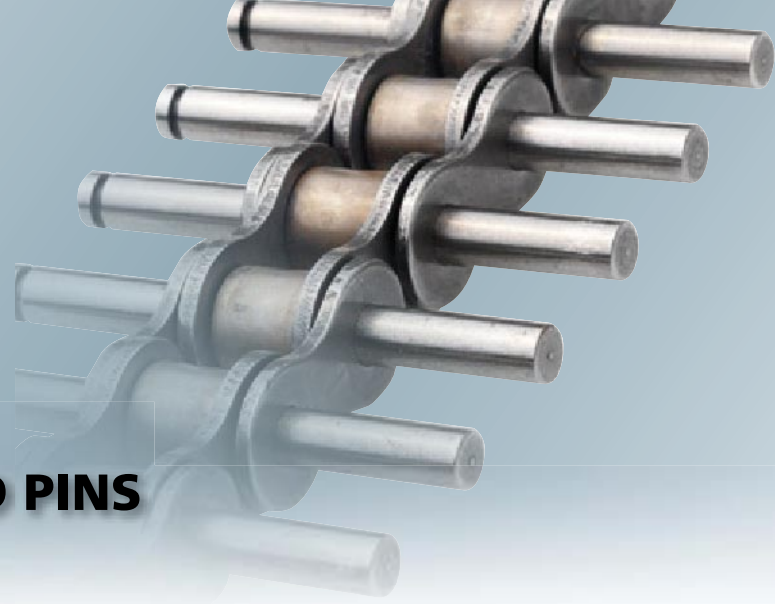

SIMPLEX ROLLER CHAINS WITH BOTH SIDE EXTENDED PINS

ČZ Standard

With on both sides extended pins

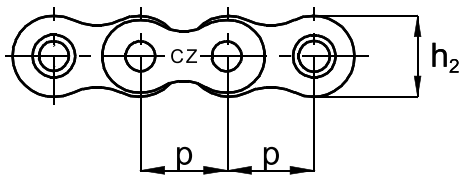

With every on both sides extended pins

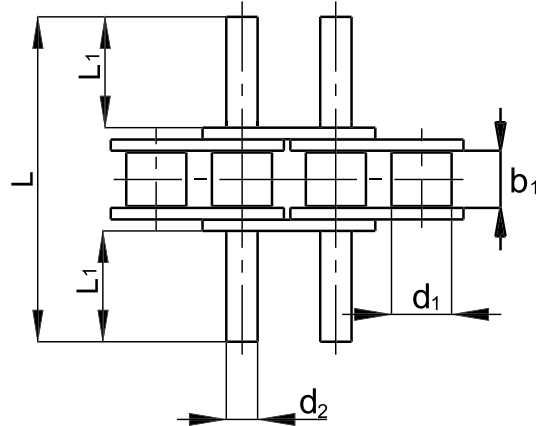
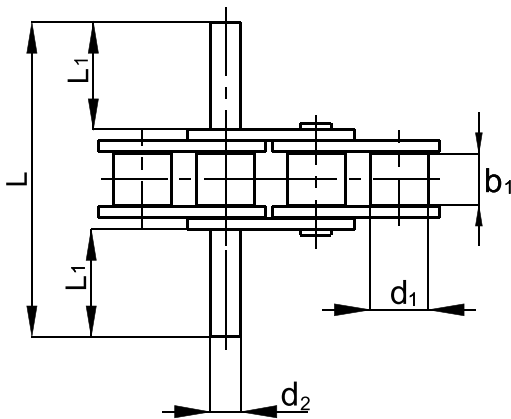
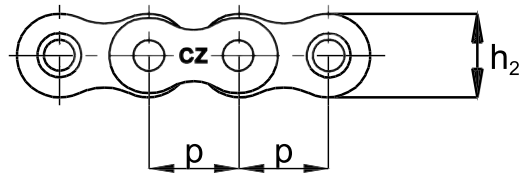

TRADE MARK ČZ	PITCH	INSIDE WIDTH	ROLLER DIAMETER	PIN DIAMETER	PIN LENGHT	PIN EXTENSION	INNER PLATE WIDTH
	p	b1 min.	d1 max.	d2 max.	L max.	L1 max.	h2 max.
	mm	mm	mm	mm	mm	mm	mm
06 B-1*	9,525	5,72	6,35	3,28	22,65	6,00	8,20
06 B-1*	9,525	5,72	6,35	3,28	32,90	11,00	8,20
06 B-1*	9,525	5,72	6,35	3,30	14,90	1,80	8,20
081	12,7	3,30	7,75	3,66	13,20	2,50	9,90
1/2"x3/16" VELO	12,7	4,88	7,75	3,66	11,50	1,00	9,90
1/2"x3/16" MOFA	12,7	4,88	7,75	4,09	14,00	1,35	10,90
1/2"x3/16" MOFA	12,7	4,88	7,75	4,18	33,70	11,25	10,90
08 B-1	12,7	7,75	8,51	4,45	17,60	1,60	11,80
08 B-1	12,7	7,75	8,51	4,45	18,20	1,80	11,80
08 B-1	12,7	7,75	8,51	4,45	19,00	2,20	11,80
08 B-1	12,7	7,75	8,51	4,45	30,45	7,95	11,80
08 B-1	12,7	7,75	8,51	4,45	40,55	13,00	11,80

SIMPLEX ROLLER CHAINS WITH BOTH SIDE EXTENDED PINS

ČZ Standard

TRADE MARK ČZ	PITCH	INSIDE WIDTH	ROLLER DIAMETER	PIN DIAMETER	PIN LENGTH	PIN EXTENSION	INNER PLATE WIDTH
	p	b1 min.	d1 max.	d2 max.	L max.	L1 max.	h2 max.
	mm	mm	mm	mm	mm	mm	mm
08 B-1	12,7	7,75	8,51	4,45	44,25	14,80	11,80
08 B-1	12,7	7,75	8,51	4,45	55,65	20,55	11,80
101	15,875	6,48	10,16	5,08	18,70	2,60	14,50
10 A-1	15,875	9,53	10,16	5,08	40,00	11,00	14,50
10 B-1	15,875	9,65	10,16	5,08	26,10	4,70	14,50
10 B-1	15,875	9,65	10,16	5,08	35,30	9,20	14,50
10 B-1	15,875	9,65	10,16	5,08	51,90	17,60	14,50
12 B-1	19,05	11,68	12,07	5,72	25,60	3,00	16,10
12 B-1	19,05	11,68	12,07	5,72	41,75	11,00	16,10
12 B-1	19,05	11,68	12,07	5,72	61,25	20,80	16,10
16 B-1	25,4	17,02	15,88	8,28	39,80	3,90	21,00
16 B-1	25,4	17,02	15,88	8,28	67,30	17,60	21,00
16 B-1	25,4	17,02	15,88	8,28	97,50	32,70	21,00
16 B-1	25,4	17,02	15,88	8,28	99,10	33,60	21,00
212 B	38,1	11,68	12,07	5,72	41,75	11,00	16,40

*Only with straight plates

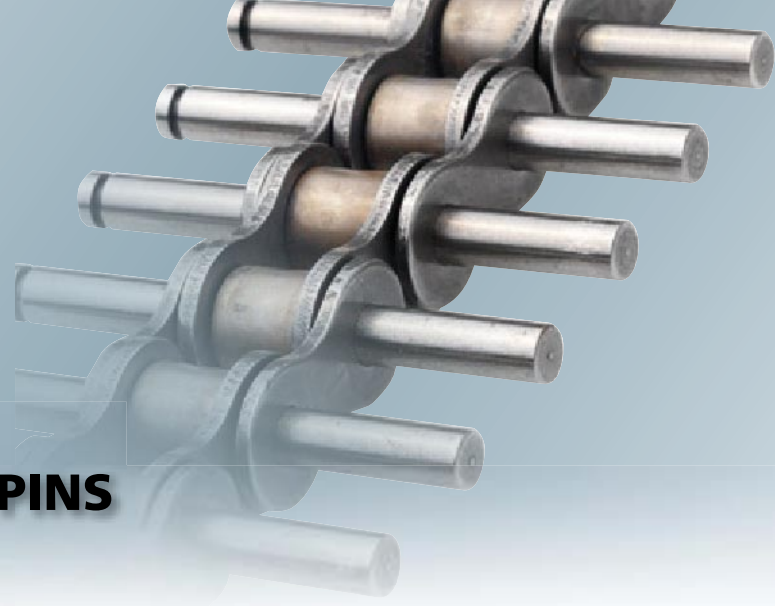

DUPLEX ROLLER CHAINS WITH ONE SIDE EXTENDED PINS

ČZ Standard

With single extended pins

With all pins extended

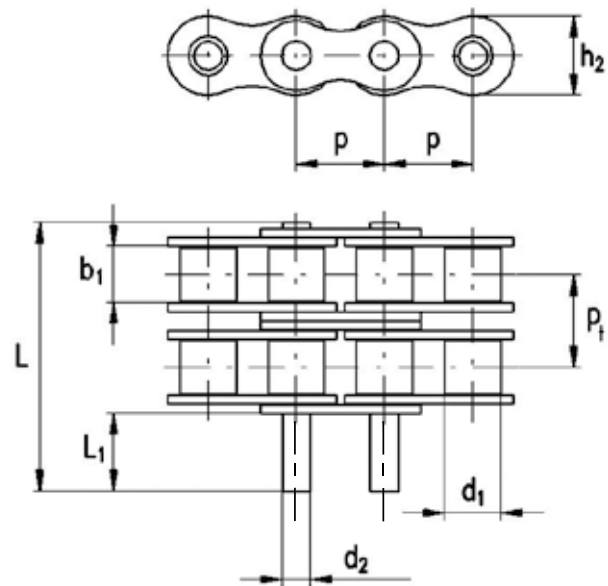
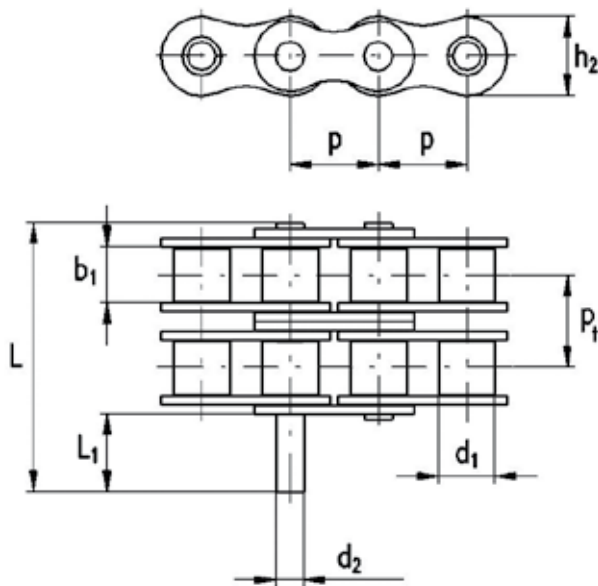

TRADE MARK ČZ	PITCH	INSIDE WIDTH	ROLLER DIAMETER	TRANSVER. PITCH	PIN DIAMETER	PIN LENGTH	PIN EXTENSION	INNER PLATE WIDTH
	p	b1 min.	d1 max.	Pt	d2 max.	L max.	L1 max.	h2 max.
	mm	mm	mm	mm	mm	mm	mm	mm
06 B-2*+	9,525	5,72	6,35	10,24	3,28	32,90	11,00	8,20
08 B-2	12,7	7,75	8,51	13,92	4,45	44,25	14,80	11,80
08 B-2	12,7	7,75	8,51	13,92	4,45	55,65	26,20	11,80
10 B-2	15,875	9,65	10,16	16,59	5,08	51,90	17,60	14,50
12 B-2	19,05	11,68	12,07	19,46	5,72	61,25	20,80	16,10
12 B-2	19,05	11,68	12,07	19,47	5,72	81,10	40,60	16,10

*ONLY WITH STRAIGHT PLATES
+ONLY WITH ONE MIDDLE PLATE

TRIPLEX ROLLER CHAINS WITH ONE SIDE EXTENDED PINS

ČZ Standard

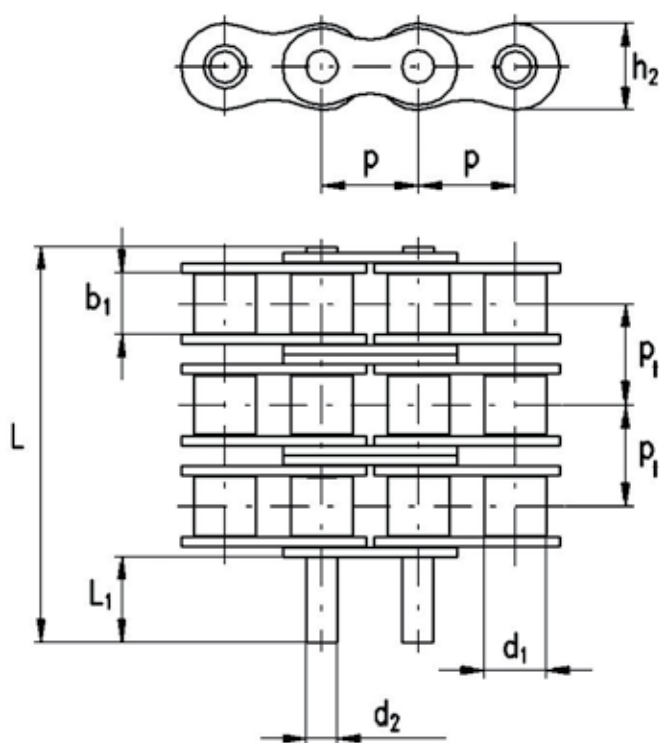

TRADE MARK ČZ	PITCH	INSIDE WIDTH	ROLLER DIAMETER	TRANSVER. PITCH	PIN DIAMETER	PIN LENGHT	PIN EXTENSION	INNER PLATE WIDTH
	p	b1 min.	d1 max.	Pt	d2 max.	L max.	L1 max.	h2 max.
	mm	mm	mm	mm	mm	mm	mm	mm
08 B-3	12,7	7,75	8,51	13,92	4,45	58,20	14,80	11,80
12 A-3	19,05	12,70	11,91	22,78	5,94	84,60	14,30	17,70

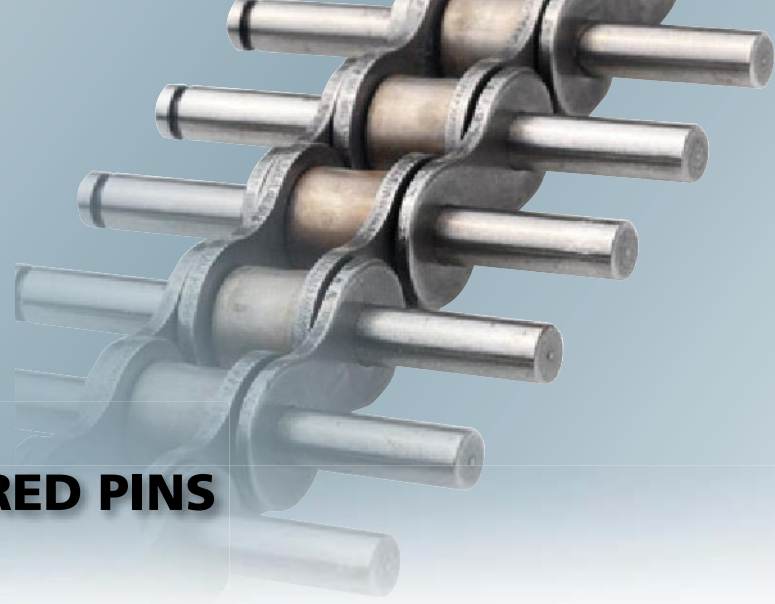

SIMPLEX ROLLER CHAINS WITH EXTENDED SHOULDERED PINS

ČZ Standard

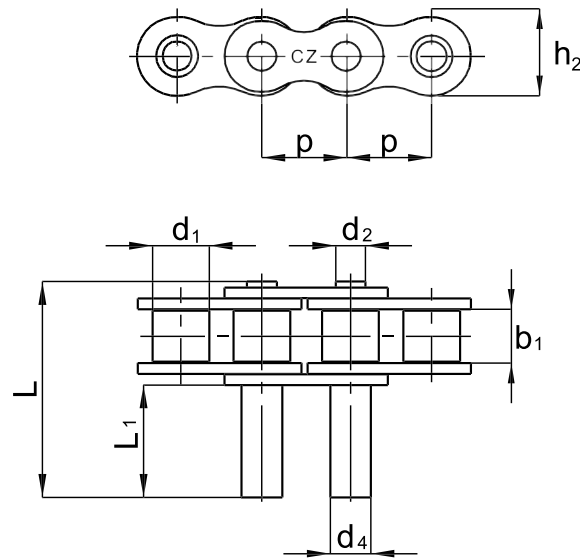

TRADE MARK ČZ	PITCH	INSIDE WIDTH	ROLLER DIAMETER	PIN DIAMETER	SHOULDER DIAMETER	PIN LENGTH	PIN EXTENSION	INNER PLATE WIDTH
	p	b1 min.	d1 max.	d2 max.	d4	L max.	L1 max.	h2 max.
	mm	mm	mm	mm	mm	mm	mm	mm
06 B-1*	9,525	5,72	6,35	3,28	4,55	28,00	16,50	8,20
06 B-1*	9,525	5,72	6,35	3,28	5,08	26,60	15,00	8,20
06 B-1*	9,525	5,72	6,35	3,28	5,08	31,50	20,00	8,20
081	12,7	3,30	7,75	3,66	4,44	22,20	13,50	9,90
081	12,7	3,30	7,75	3,66	4,45	25,50	16,50	9,90
081	12,7	3,30	7,75	3,66	4,55	31,30	22,30	9,90
081	12,7	3,30	7,75	3,66	5,00	24,00	15,00	9,90
081	12,7	3,30	7,75	3,66	5,00	33,00	24,00	9,90
081	12,7	3,30	7,75	3,66	5,17	24,00	15,00	9,90
081	12,7	3,30	7,75	3,66	5,17	31,00	22,00	9,90
410	12,7	3,30	7,75	3,66	5,00	33,00	24,00	9,90
1/2"x3/16" MOFA	12,7	4,88	7,75	4,18	5,00	35,60	23,50	10,90
08 B-1	12,7	7,75	8,51	4,45	3,90	25,60	10,00	11,80
08 B-1	12,7	7,75	8,51	4,45	4,90	21,55	5,00	11,80
08 B-1	12,7	7,75	8,51	4,45	5,00	50,55	35,00	11,80
08 B-1	12,7	7,75	8,51	4,45	5,17	31,80	15,00	11,80

*Only with straight plates

SIMPLEX ROLLER CHAINS WITH EXTENDED SHOULDERED PINS

ČZ Standard

TRADE MARK ČZ	PITCH	INSIDE WIDTH	ROLLER DIAMETER	PIN DIAMETER	SHOULDER DIAMETER	PIN LENGHT	PIN EXTENSION	INNER PLATE WIDTH
	p	b1 min.	d1 max.	d2 max.	d4	L max.	L1 max.	h2 max.
	mm	mm	mm	mm	mm	mm	mm	mm
08 B-1	12,7	7,75	8,51	4,45	6,00	31,05	15,50	11,80
08 B-1	12,7	7,75	8,51	4,45	6,06	23,55	8,00	11,80
08 B-1	12,7	7,75	8,51	4,45	6,06	30,90	15,30	11,80
08 B-1	12,7	7,75	8,51	4,45	6,06	35,55	20,00	11,80
08 B-1	12,7	7,75	8,51	4,45	6,06	37,10	21,60	11,80
08 B-1	12,7	7,75	8,51	4,45	8,00	35,55	20,00	11,80
428	12,7	7,75	8,51	4,45	5,17	31,80	15,00	12,00
10 B-1	15,875	9,65	10,16	5,08	5,50	35,30	17,50	14,50
10 B-1	15,875	9,65	10,16	5,08	5,50	37,80	20,00	14,50
10 B-1	15,875	9,65	10,16	5,08	6,06	33,85	16,00	14,50
10 B-1	15,875	9,65	10,16	5,08	6,06	68,80	51,00	14,50
10 B-1	15,875	9,65	10,16	5,08	6,60	37,80	20,00	14,50
10 B-1	15,875	9,65	10,16	5,08	8,00	37,70	20,00	14,50
10 B-1	15,875	9,65	10,16	5,08	8,00	44,80	27,00	14,50
10 B-1	15,875	9,65	10,16	5,08	8,00	57,80	40,00	14,50
10 B-1	15,875	9,65	10,16	5,08	10,00	32,80	15,00	14,50
10 B-1	15,875	9,65	10,16	5,08	10,00	43,00	25,20	14,50
12 B-1	19,05	11,68	12,07	5,72	5,90	33,20	12,20	16,10
12 B-1	19,05	11,68	12,07	5,72	6,90	80,30	40,00	16,10
12 B-1	19,05	11,68	12,07	5,72	7,00	41,00	20,00	16,10
12 B-1	19,05	11,68	12,07	5,72	7,00	47,00	26,00	16,10
12 B-1	19,05	11,68	12,07	5,72	7,00	51,00	30,00	16,10
12 B-1	19,05	11,68	12,07	5,72	7,00	52,70	31,70	16,10
12 B-1	19,05	11,68	12,07	5,72	8,00	47,00	26,00	16,10
12 B-1	19,05	11,68	12,07	5,72	8,00	56,00	35,00	16,10
12 B-1	19,05	11,68	12,07	5,72	8,00	61,40	40,40	16,10
12 B-1	19,05	11,68	12,07	5,72	10,00	41,00	20,00	16,10
12 B-1	19,05	11,68	12,07	5,72	10,27	41,00	20,00	16,10
16 B-1	25,4	17,02	15,88	8,28	6,00	67,30	33,60	21,00
16 B-1	25,4	17,02	15,88	8,28	9,00	67,30	33,60	21,00
16 B-1	25,4	17,02	15,88	8,28	10,00	63,80	30,00	21,00
208 B	25,4	7,75	8,51	4,45	6,06	30,90	15,30	12,00
212 B	38,1	11,68	12,07	5,72	7,00	47,00	26,00	16,40

The position of extended shouldered pins must be consulted with the producer

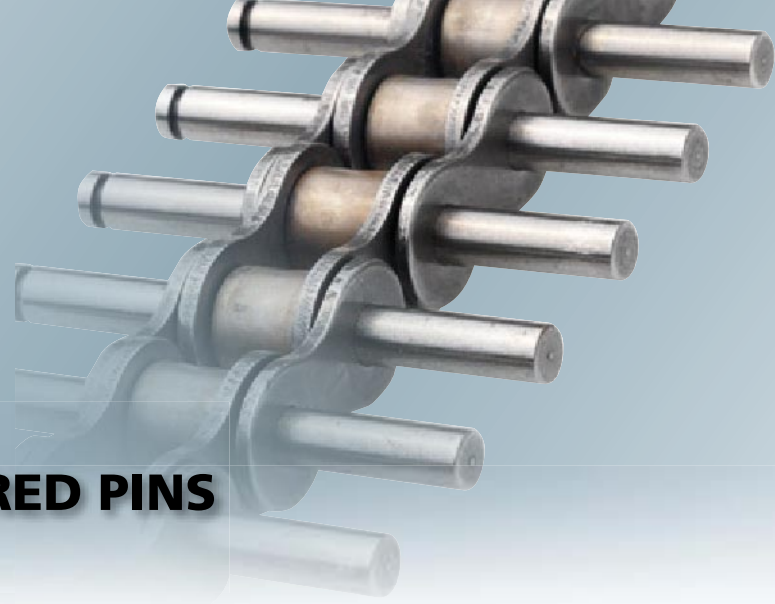

DUPLEX ROLLER CHAINS WITH EXTENDED SHOULDERED PINS

ČZ Standard

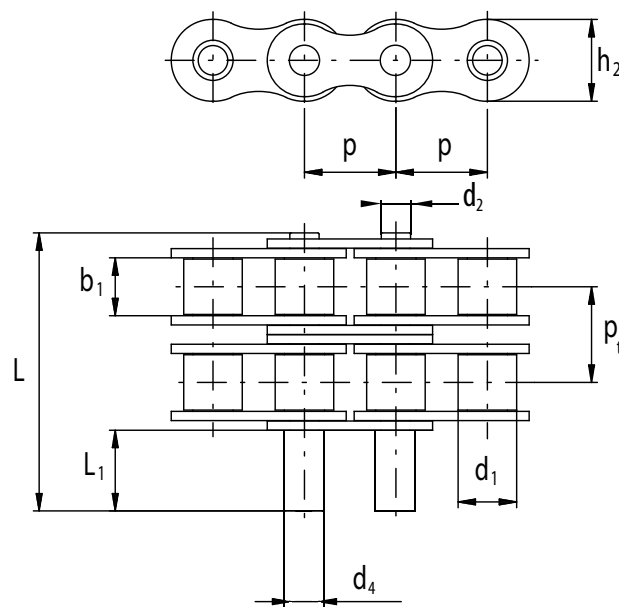

TRADE MARK ČZ	PITCH	INSIDE WIDTH	ROLLER DIAMETER	PIN DIAMETER	SHOULDER DIAMETER	PIN LENGTH	PIN EXTENSION	INNER PLATE WIDTH
	p	b1 min.	d1 max.	d2 max.	d4	L max.	L1 max.	h2 max.
	mm	mm	mm	mm	mm	mm	mm	mm
10 B-2	15,875	9,65	10,16	5,08	6,06	49,30	15,00	14,50
16 B-2	25,4	17,02	15,88	8,28	12,00	85,60	19,90	21,00

The position of extended shouldered pins must be consulted with the producer

SPECIAL EXTENDED PINS

ČZ Standard

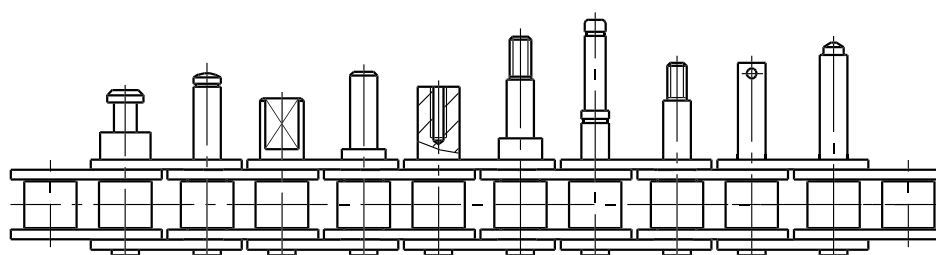

Most of roller and bush chains in single and multiple row modification can be equipped with extended pins according to individual customer request - see picture above.

The pins can be equipped with grooves for the adjusting plate or adjusting ring, they can also have a holes for cotter, outer and inner thread, spots, or they can be multiple shouldered. Dimensions of these special pins, their position and also the basic chain modification must be consulted with producer.

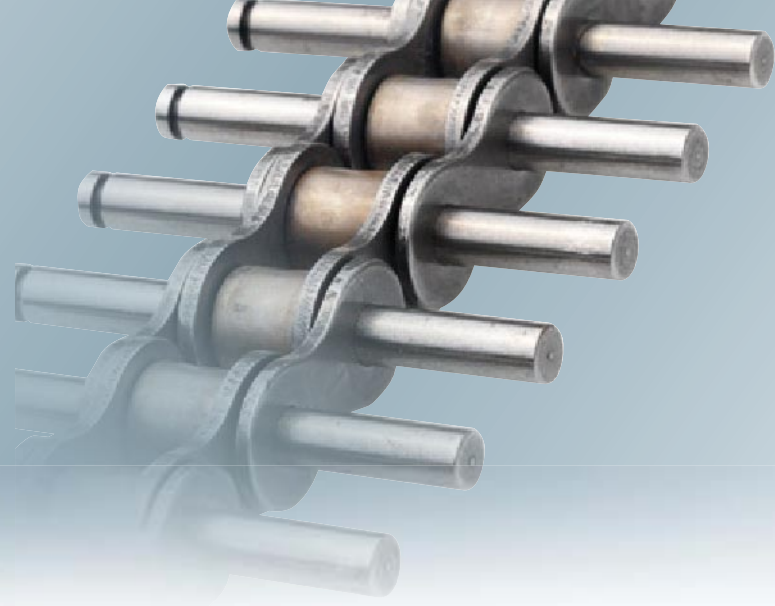

SIMPLEX ROLLER CHAINS WITH HOLLOW PINS

ČZ Standard

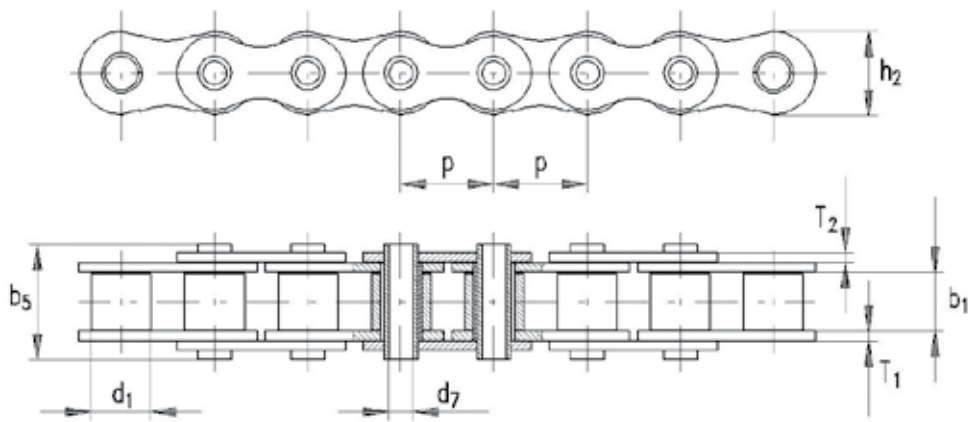

MODIFICATION 1.

TRADE MARK ČZ	PITCH	INSIDE WIDTH	ROLLER DIAMETER	HOLE DIAMETER IN THE PIN	PIN LENGTH	INNER PLATE WIDTH	INNER PLATE THICKNESS	OUTER PLATE THICKNESS	WEIGHT	BREAKING LOAD	CONNECT. ELEMENTS	
											A	B
	p	b1 min.	d1 max.	d7 min.	b5 max.	h2 max.	T1	T2	q	FB min.		
	mm	mm	mm	mm	mm	mm	mm	mm	kg/m	N		
12 B-1	19,05	11,68	12,07	4,10	22,30	16,10	1,80	1,80	1,09	21 700	•	•

CONNECTING ELEMENTS



B

A

SIMPLEX ROLLER CHAINS WITH HOLLOW PINS

ČZ Standard

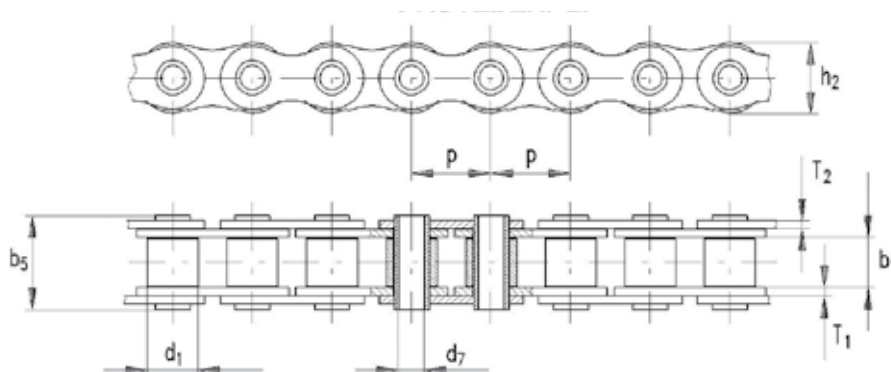

MODIFICATION 2.

TRADE MARK ČZ	PITCH	INSIDE WIDTH	ROLLER DIAMETER	HOLE DIAMETER IN THE PIN	PIN LENGTH	INNER PLATE WIDTH	INNER PLATE THICKNESS	OUTER PLATE THICKNESS	WEIGHT	BREAKING LOAD	CONNECT. ELEMENTS
	p	b1 min.	d1 max.	d7 min.	b5 max.	h2 max.	T1	T2	q	FB min.	A
	mm	mm	mm	mm	mm	mm	mm	mm	kg/m	N	
08 B-1	12,7	7,75	8,51	4,50	15,20	11,80	1,60	1,40	0,55	8 700	•
08 B-1	12,7	7,75	8,51	4,50	16,60	11,80	1,60	1,40	0,57	8 700	•
10 B-1	15,875	9,65	10,16	4,10	20,00	14,50	2,00	2,00	0,90	20 290	•
10 B-1	15,875	9,65	10,16	5,13	20,00	14,50	2,00	2,00	0,87	20 290	•
12 A-1	19,05	12,70	11,91	5,15	24,60	17,70	2,40	2,40	1,24	13 920	•
12 A-1	19,05	12,70	11,91	6,10	24,60	17,70	2,40	2,40	1,24	13 920	•

CONNECTING ELEMENTS



A

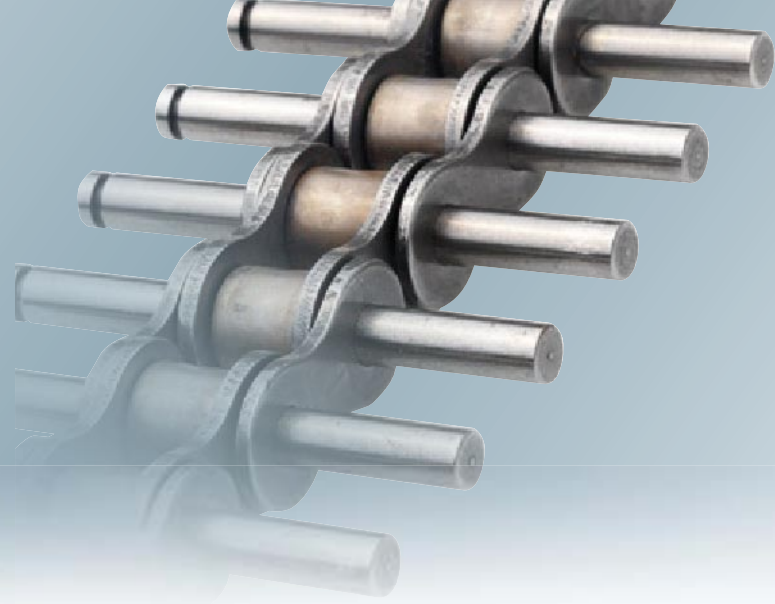

DUPLEX ROLLER CHAINS WITH HOLLOW PINS

ČZ Standard

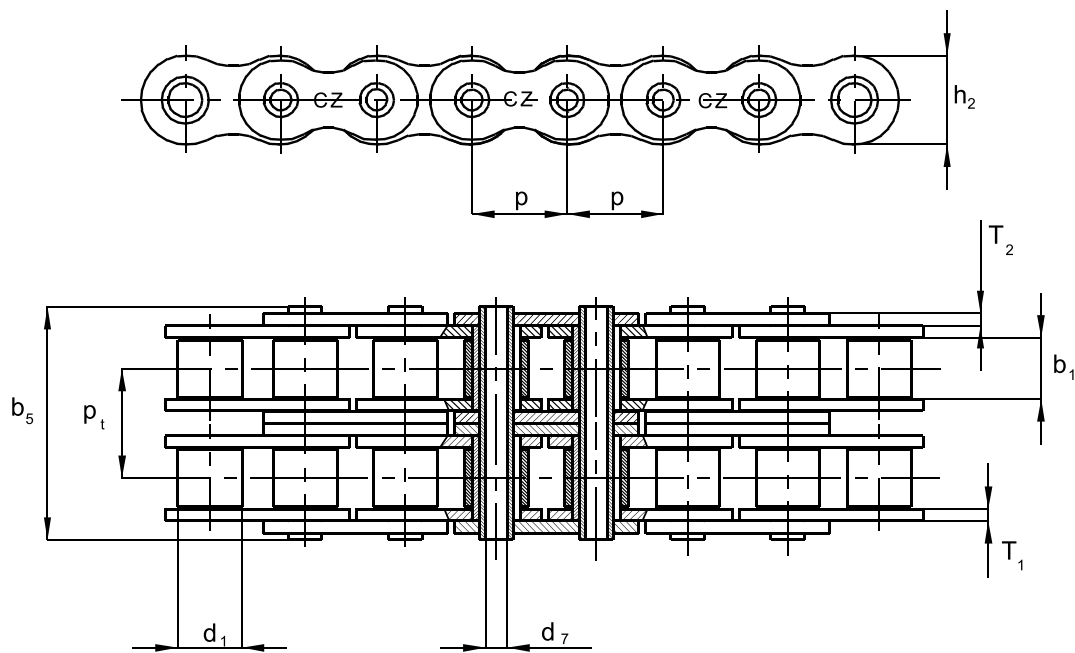

MODIFICATION 1.

TRADE MARK ČZ	PITCH	INSIDE WIDTH	ROLLER DIAMETER	HOLE DIAMETER IN THE PIN	PIN LENGTH	INNER PLATE WIDTH	INNER PLATE THICKNESS	OUTER PLATE THICKNESS	TRANSVER. PITCH	WEIGHT	BREAKING LOAD	CONNECT. ELEMENTS	
	p	b1 min.	d1 max.	d7 min.	b5 max.	h2 max.	T1	T2	Pt	q	FB min.	B	A
	mm	mm	mm	mm	mm	mm	mm	mm	mm	kg/m	N		
08B-2	12,70	7,75	8,51	3,20	30,90	11,80	1,60	1,40	13,92	1,22	32,655	•	•

CONNECTING ELEMENTS

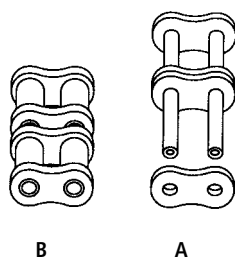

DUPLEX ROLLER CHAINS WITH HOLLOW PINS

ČZ Standard

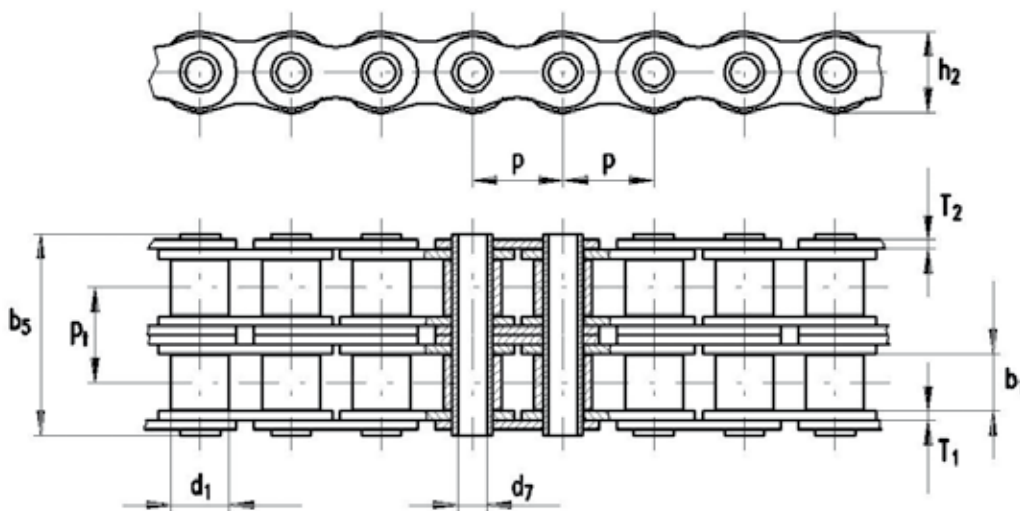

MODIFICATION 2.

TRADE MARK ČZ	PITCH	INSIDE WIDTH	ROLLER DIAMETER	HOLE DIAMETER IN THE PIN	PIN LENGTH	INNER PLATE WIDTH	INNER PLATE THICKNESS	OUTER PLATE THICKNESS	TRANSVER. PITCH	WEIGHT	BREAKING LOAD	CONNECT. ELEMENTS
	p	b1 min.	d1 max.	d7 min.	b5 max.	h2 max.	T1	T2	Pt	q	FB min.	A
	mm	mm	mm	mm	mm	mm	mm	mm	mm	kg/m	N	
12 A-2	19,05	12,70	11,91	6,05	48,65	17,70	2,40	2,40	22,78	2,27	25 000	•

CONNECTING ELEMENTS

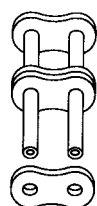

A

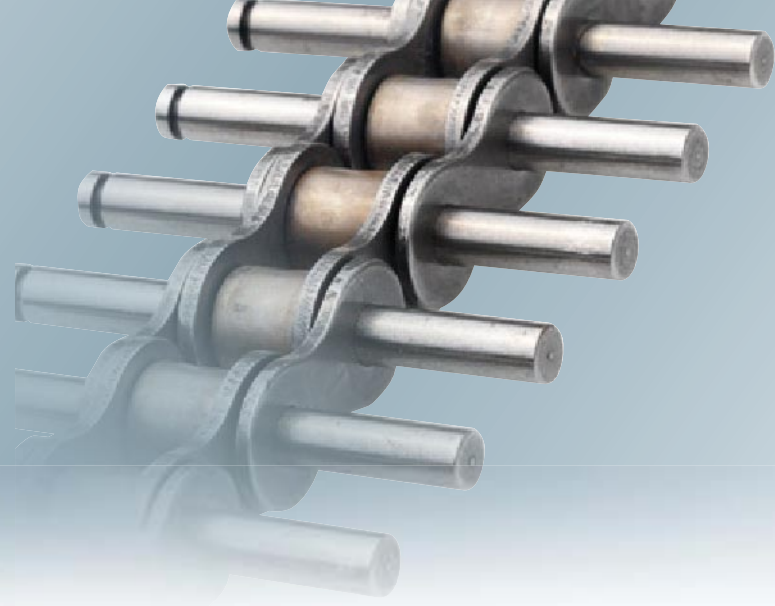

SIMPLEX ROLLER CHAINS WITH EXTENDED BARS

ČZ Standard

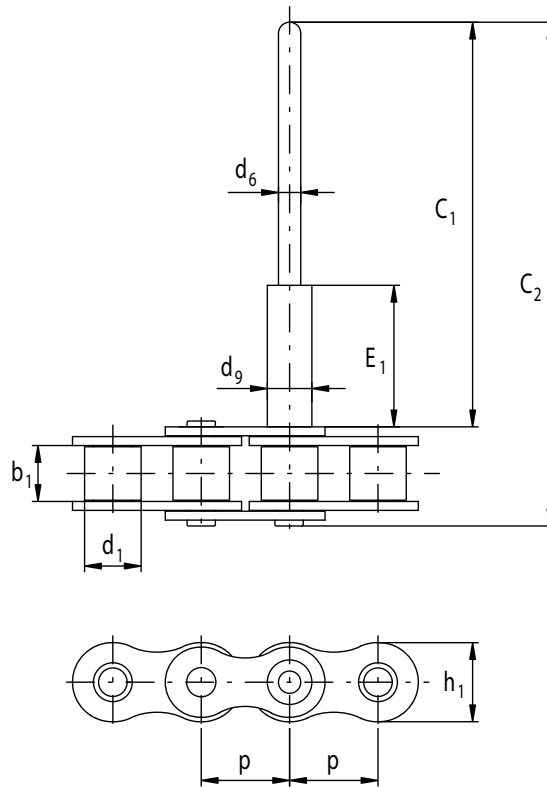

TRADE MARK ČZ	PITCH	INSIDE WIDTH	ROLLER DIAMETER	CONNECTING ELEMENT DIAMETER	BAR EXTENSION	CONNECTING LINK LENGTH	BAR EXTENSION	WHOLE LENGTH	INNER PLATE WIDTH
	p	b1 min.	d1 max.	d9	d6	E1	C1	C2	h2 max.
	mm	mm	mm	mm	mm	mm	mm	mm	mm
08 B-1	12,7	7,75	8,51	8,00	3,97	22,00	175,00	190,50	11,80
10 B-1	15,875	9,65	10,16	8,00	4,00	35,00	246,00	264,00	14,50
10 B-1	15,875	9,65	10,16	8,00	3,97	35,00	242,00	260,00	14,50
10 B-1	15,875	9,65	10,16	8,00	3,00	22,00	160,00	177,70	14,50
12 B-1	19,05	11,68	12,07	9,00	4,00	22,00	273,00	294,00	16,10
12 B-1	19,05	11,68	12,07	9,00	3,97	22,00	232,00	253,00	16,10
12 B-1	19,05	11,68	12,07	9,00	3,97	22,00	278,00	299,00	16,10

Bars position must be consulted with producer
According to customer request a dural extender can be press on the bar end

ROLLER CHAINS WITH ROTARY BUSHES

ČZ Standard

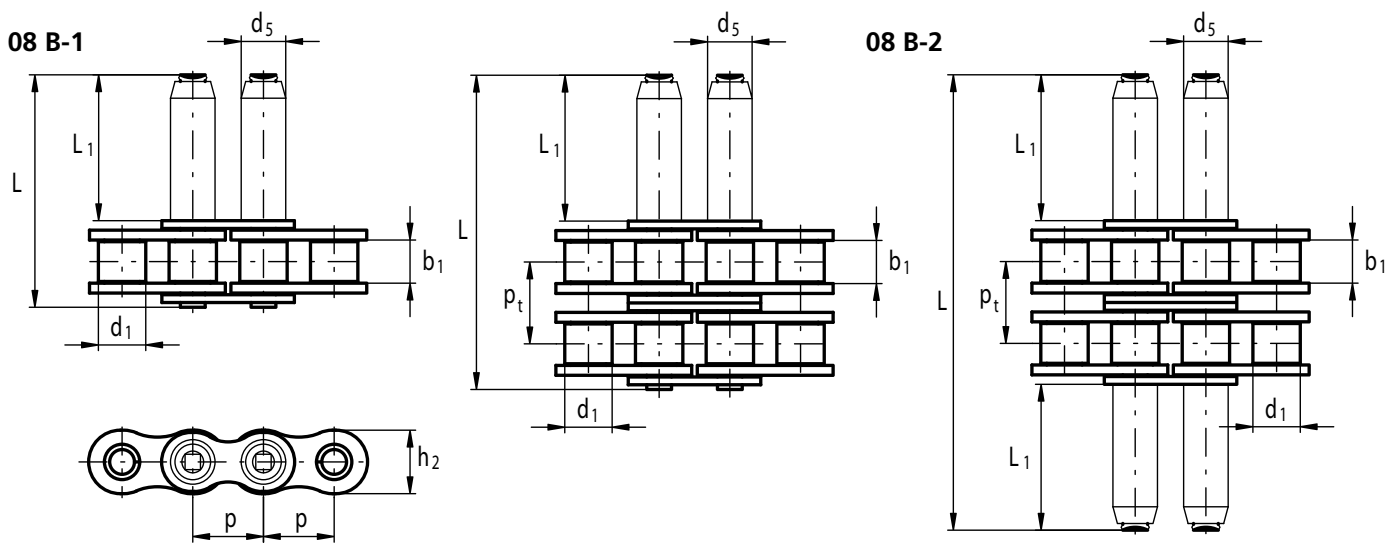

TRADE MARK ČZ	PITCH	INSIDE WIDTH	ROLLER DIAMETER	BUSH DIAMETER	PIN LENGTH	PIN EXTENSION	TRANSVER. PITCH	INNER PLATE WIDTH	BUSHES POSITIONING
	p	b_1 min.	d_1 max.	d_5	L max.	L_1 max.	p_t	h_2 max.	
	mm	mm	mm	mm	mm	mm	mm	mm	
08 B-1	12,7	7,75	8,51	8,00	41,80	26,20	-	11,80	one side
08 B-2	12,7	7,75	8,51	8,00	55,65	26,20	13,92	11,80	one side
08 B-2	12,7	7,75	8,51	8,00	80,85	26,20	13,92	11,80	both sides

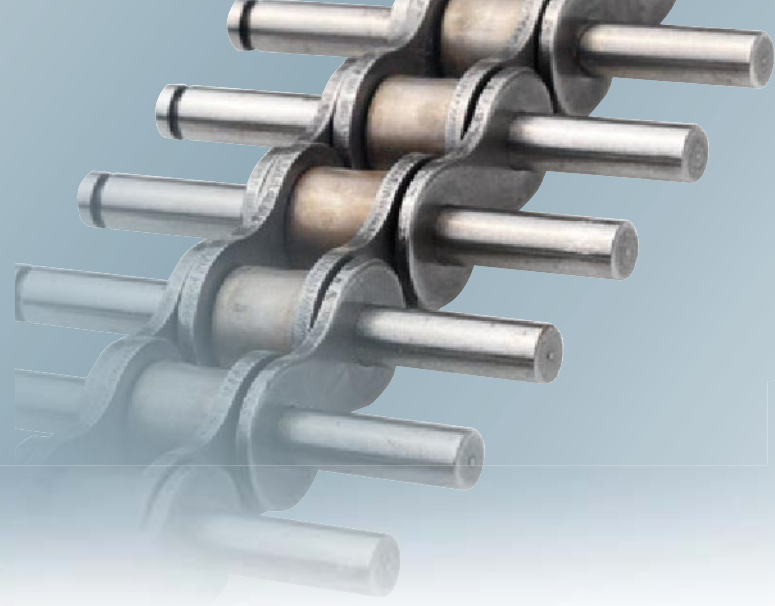

CONVEYOR CHAIN BELTS

ČZ Standard

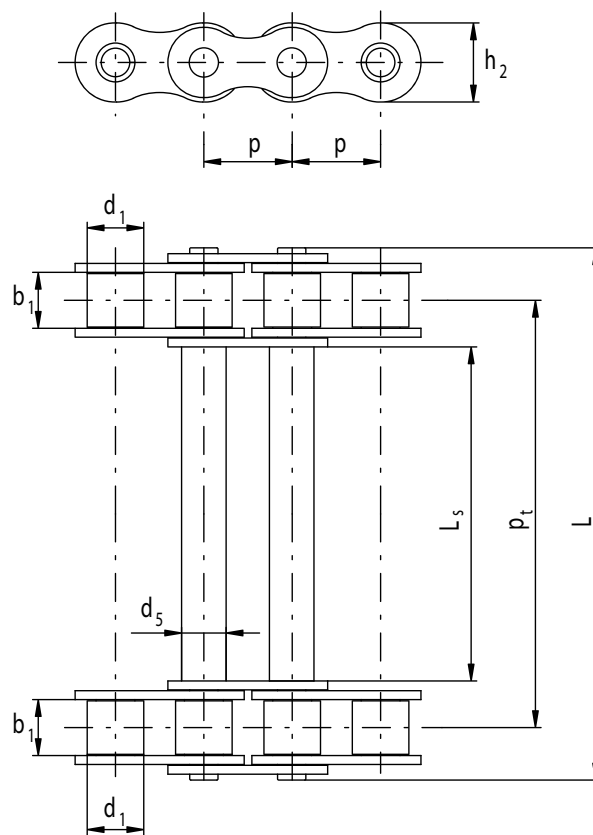

TRADE MARK ČZ	PITCH	INSIDE WIDTH	ROLLER DIAMETER	CONNECTING ELEMENT DIAMETER	WIDTH BETWEEN THE CHAINS	TRANSVERSAL PITCH	PIN LENGHT	INNER PLATE WIDTH
	p	b1 min.	d1 max.	d5	Ls	pt	L max.	h2 max.
	mm	mm	mm	mm	mm	mm	mm	mm
08 B	12,7	7,75	8,51	8,50	30,80	45,50	62,00	11,80
10 B1)	15,875	9,65	10,16	8,00	60,00	76,75	99,10	14,50
12 B	19,05	11,68	12,07	7,50	50,50	70,00	92,30	16,10

1) ONLY WITH SPECIAL CONNECTING ELEMENT

The connecting items can be positioned according to individual customer request - must be consulted with producer

SPECIAL CHAINS

ČZ Standard

Side bow roller chains	84
Side bow roller chains with attachments M1, M2	85
Side bow roller chains with attachments K1, K2	86
Side bow roller chains with attachments K7, K8	87
Side bow roller chains with one side extended pins	88
Side bow roller chains with both side extended pins	89
Duplex-Strand roller chains with U-Type attachments	
Duplex-strand roller chains with U-Type rubber attachments	90
Triplex-Strand roller chains with U-Type attachments	
Triplex-Strand roller chains with U-Type rubber attachments	91
6-Row roller chains with U-Type attachments	
6-Row roller chains with U-Type rubber attachments	92
Conveyor chains with plastic or steel rollers - Type A	93
Conveyor chains with plastic or steel rollers - Type C	94–95
Simplex conveyor chains with side transporting rollers	96
Duplex conveyor chains with one side transporting rollers	97
Duplex conveyor chains with middle transporting rollers	98
Simplex conveyor chains with transporting rollers on the upper row	
with special attachments M2, M8	99
Duplex conveyor chains with transporting rollers on the upper row with special	
Attachments M8	100
Double pitch atypical roller chains	101
Atypical roller chains	102–103

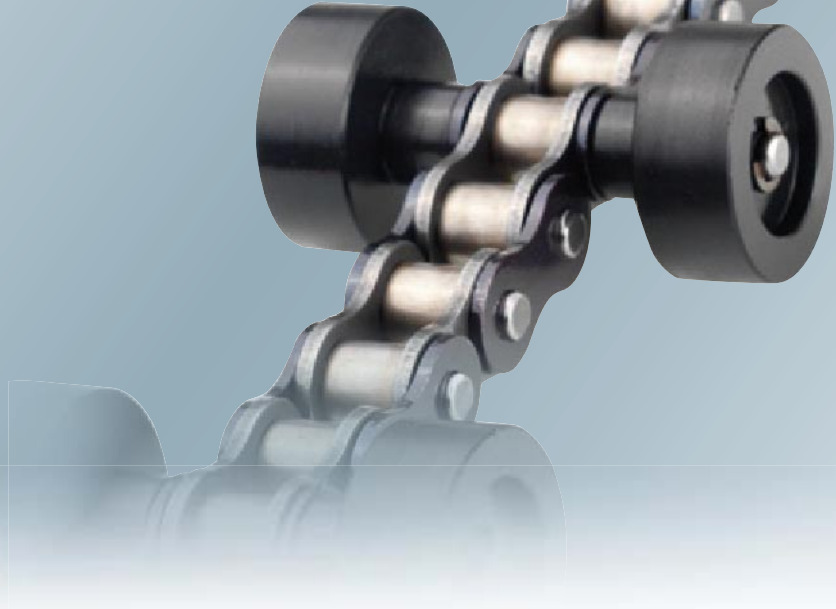

Conveyor chains with rollers are another industrially very important group of special chains. They are used for transport of goods like pallets, cases, packets, etc.

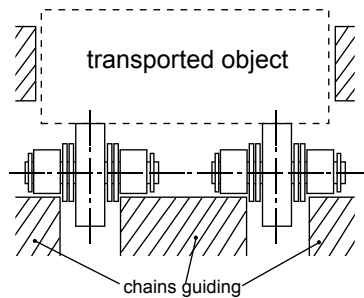

Their field of application is in furniture industry and in conveying systems because when the goods are stopped (for example in interoperation), the rollers are freely turning so that the chain could move without any friction between the goods and the chain.

Chains with steel or rubber U-type attachments are used in lines for transport of for example wooden plates. Their advantage: the transported object is not damaged and it does not slide (at rubber attachments).

The object cannot stop on the conveyor if we want to avoid its damaging.

Side bow roller chains are specially designed chains that allow using of the chain in certain defined radius. This is not possible at all the other chains that have to work only in directness.

Chains are manufactured with shaped pins whose quality but also the price are higher, or with larger side clearance where the chain durability is lowered.

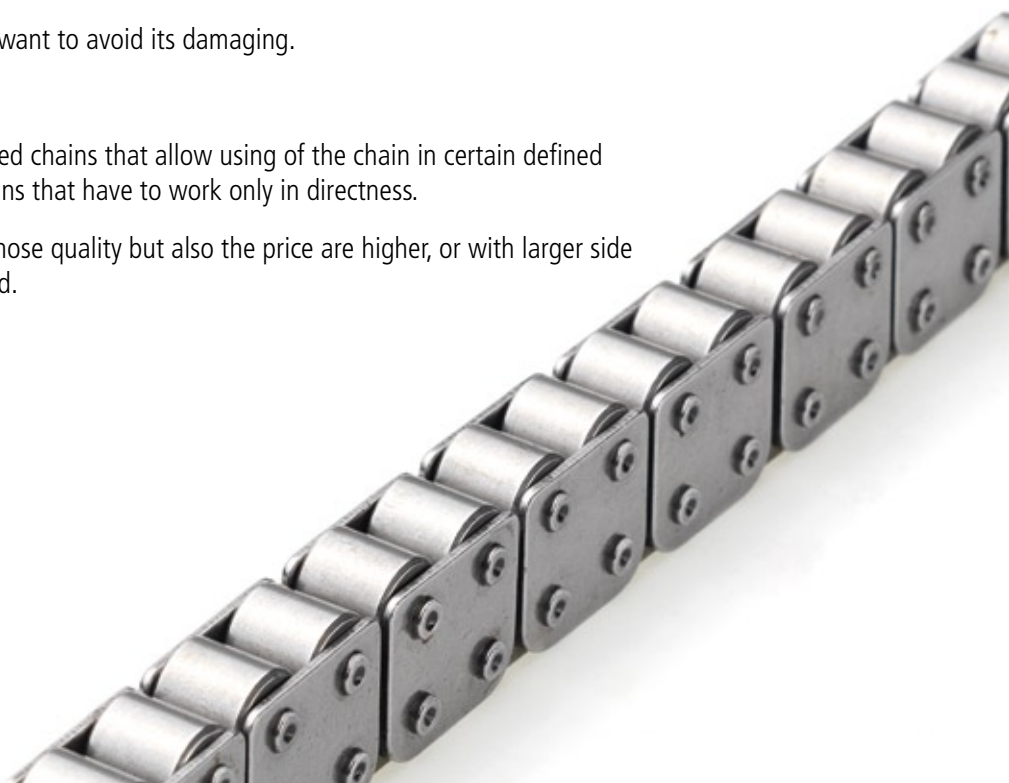

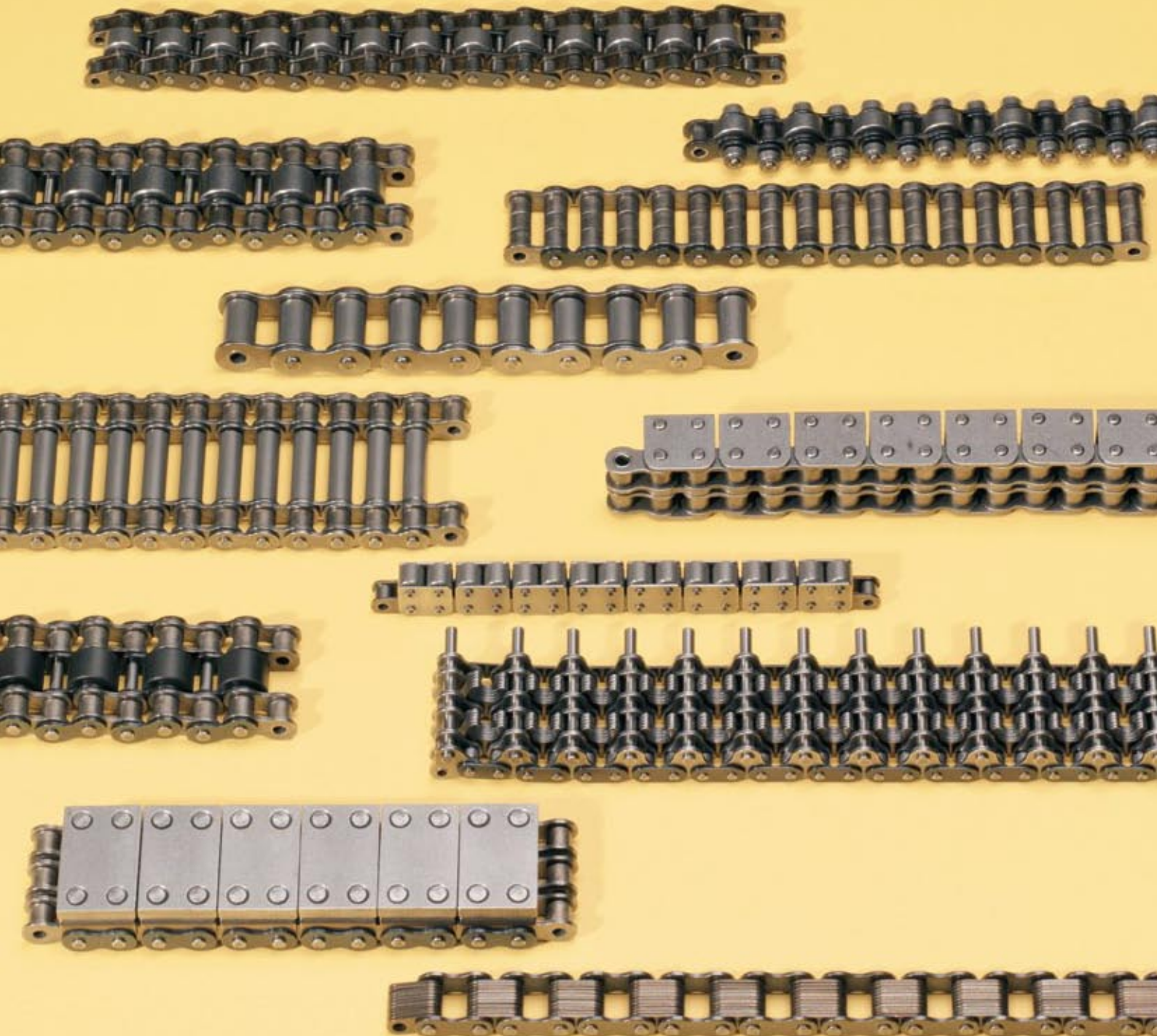

SPECIAL CONVEYOR CHAINS WITH ROLLERS

- are used for transport of goods, like pallets, cases, packets

CHAINS WITH STEEL OR RUBBER U - TYPE ATTACHMENTS

- are used for transport of fragile articles

SIDEBOW CHAINS

- are used in certain defined radius

Applications: conveyors in stocks, woollen, steel, wood, building materials and food industry



SIDE BOW ROLLER CHAINS

ČZ Standard

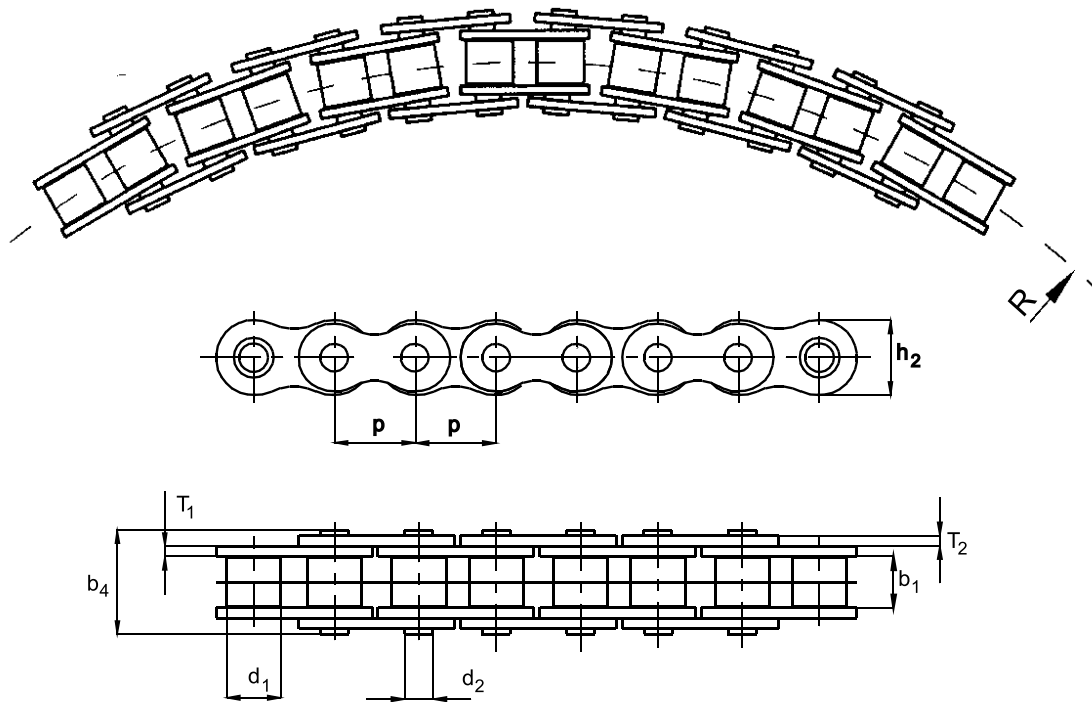

TRADE MARK ČZ	PITCH	INSIDE WIDTH	ROLLER DIAMETER	PIN DIAMETER	PIN LENGTH	INNER PLATE WIDTH	INNER PLATE THICKNESS	OUTER PLATE THICKNESS	SIDE BOW	BREAKING LOAD	CONNECTING ELEMENTS			
											B	A	E	S
	p	b1 min.	d1 max.	d2 max.	b4 max.	h2 max.	T1	T2	R	FB min.				
	mm	mm	mm	mm	mm	mm	mm	mm	mm	N				
08 B-1	12,7	7,75	8,51	4,45	16,80	11,80	1,60	1,40	370	18 690	•	•	•	•
10 B-1	15,875	9,65	10,16	5,08	19,30	14,50	1,60	1,60	500	23 310	•	•	•	•
12 B-1	19,05	11,68	12,07	5,72	22,30	16,10	1,80	1,80	650	30 345	•	•	•	•

CONNECTING ELEMENTS

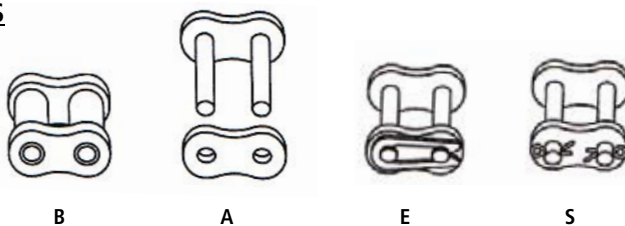

SIDE BOW ROLLER CHAINS WITH ATTACHMENTS M1, M2

ČZ Standard

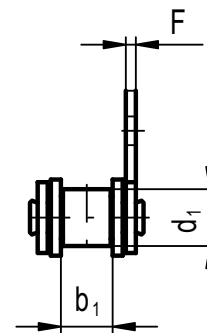
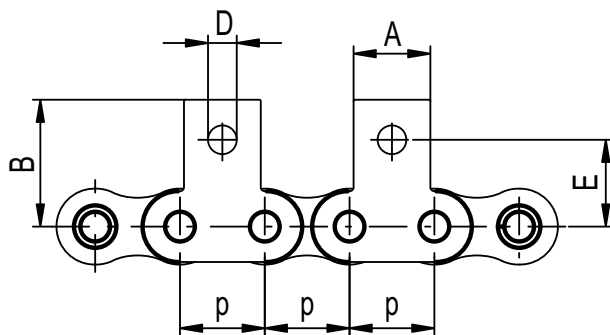
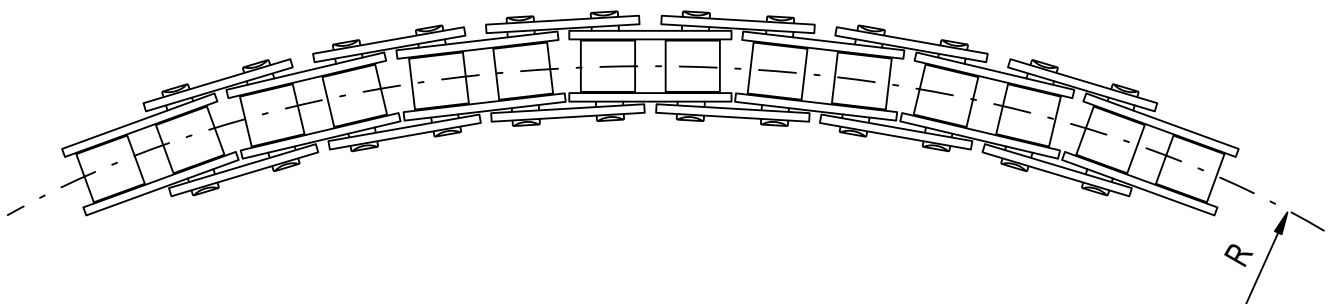

TYPE M1

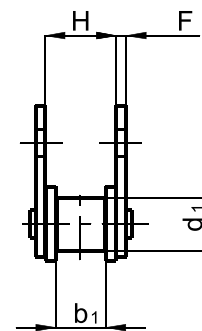

TYPE M2
R2

TRADE MARK ČZ	PITCH	INSIDE WIDTH	ROLLER DIAMETER	DIMENSION	DIMENSION	ATTACHMENT HOLE DIAMETER	DIMENSION	DIMENSION	ATTACHMENT PLATE THICKNESS	SIDE BOW	BREAKING LOAD
	p	b1 min.	d1 max.	A	B	D	E	H	F	R min.	FB min.
	mm	mm	mm	mm	mm	mm	mm	mm	mm	mm	N
08 B-1M1	12,7	7,75	8,51	11,50	19,00	4,30	13,00	-	1,40	400	18 690
08 B-1M2	12,7	7,75	8,51	11,50	19,00	4,30	13,00	11,90	1,40	400	18 690

Position of the attachments M1, M2 must be consulted with producer

SIDE BOW ROLLER CHAINS WITH ATTACHMENTS K1, K2

ČZ Standard

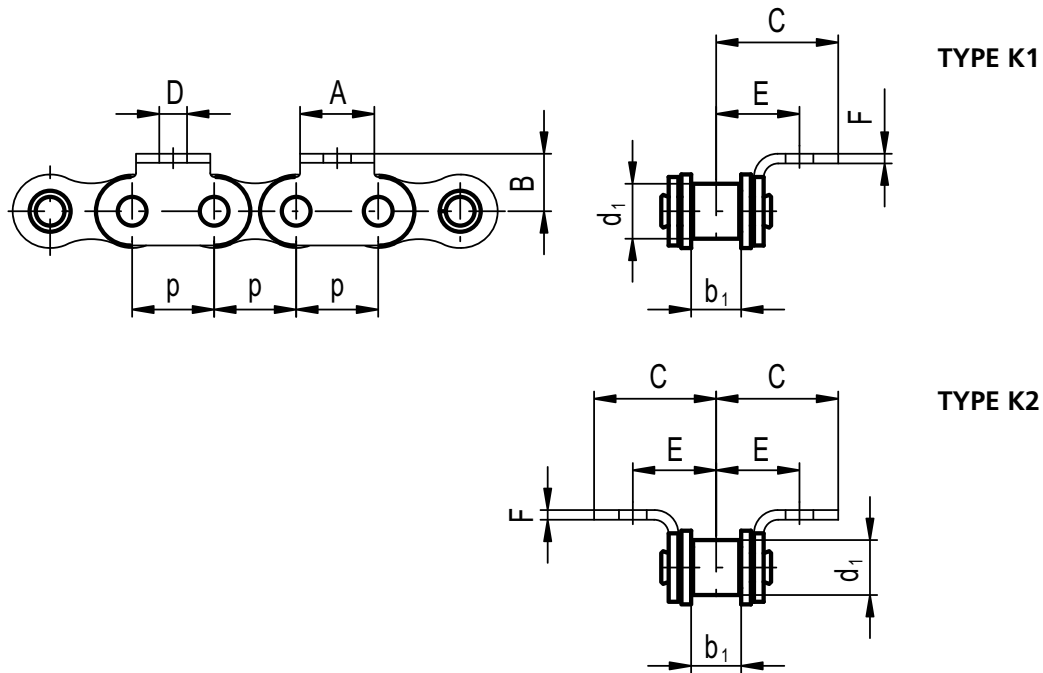
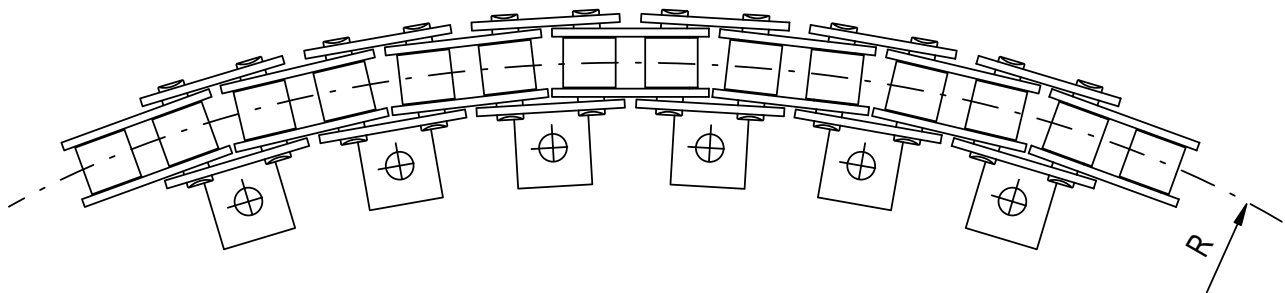

TRADE MARK ČZ	PITCH	INSIDE WIDTH	ROLLER DIAMETER	DIMENSION	DIMENSION	ATTACHMENT HOLE DIAMETER	DIMENSION	DIMENSION	ATTACHMENT PLATE THICKNESS	SIDE BOW	BREAKING LOAD
	p	b ₁ min.	d ₁ max.	A	B	D	E	C	F	R min.	FB min.
	mm	mm	mm	mm	mm	mm	mm	mm	mm	mm	N
08 B-1 K1	12,7	7,75	8,51	11,50	8,90	4,30	12,90	18,90	1,40	400	18 690
10 B-1 K1	15,875	9,65	10,16	14,00	10,30	5,30	16,20	24,20	1,60	500	23 310
10 B-1 K2	15,875	9,65	10,16	14,00	10,30	5,30	16,20	24,20	1,60	500	23 310

Position of the attachments K1, K2 must be consulted with producer

SIDE BOW ROLLER CHAINS WITH ATTACHMENTS K7, K8

ČZ Standard

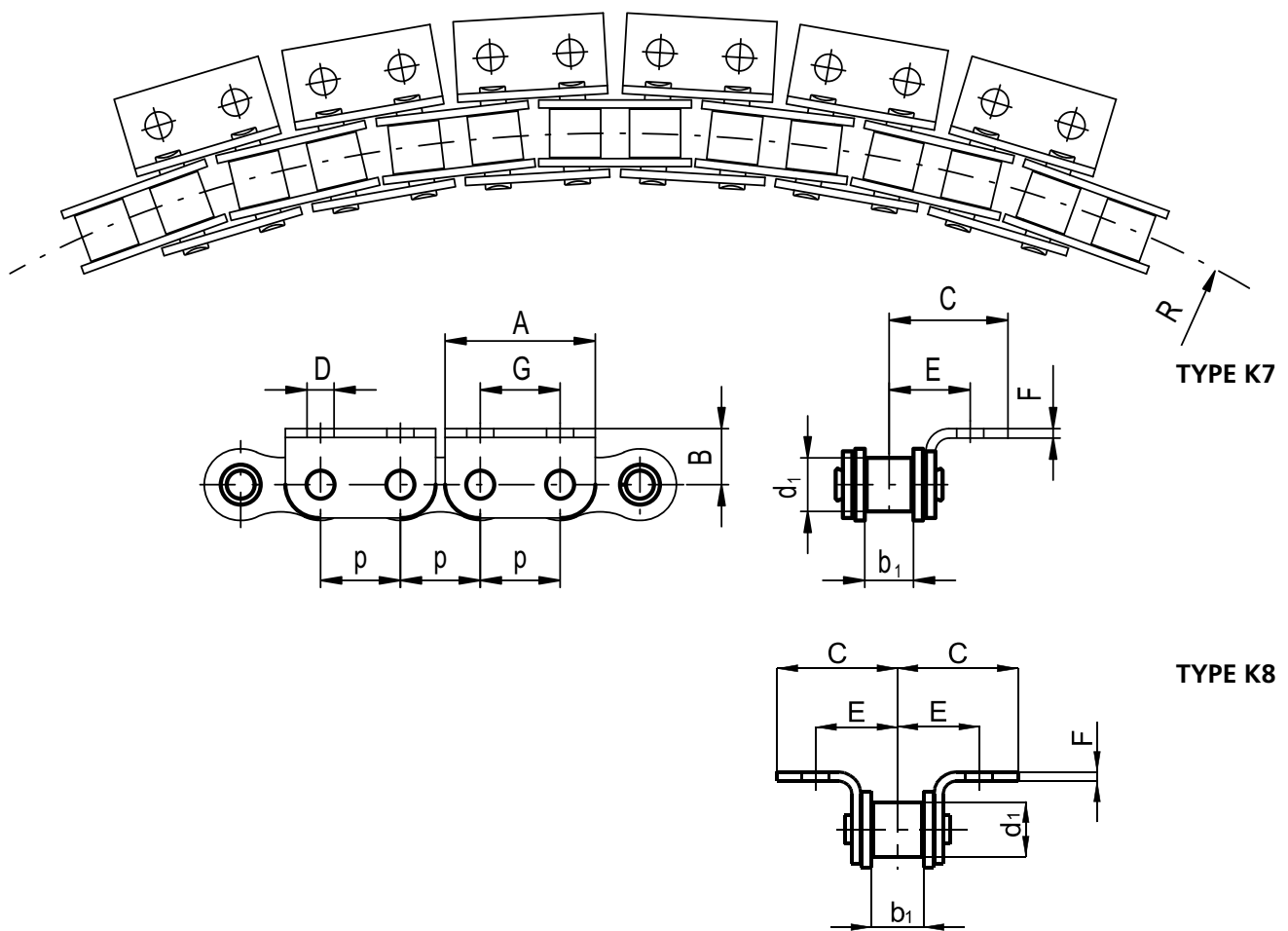

TRADE MARK ČZ	PITCH	INSIDE WIDTH	ROLLER DIAMETER	DIMENSION	DIMENSION	ATTACHMENT HOLE DIAMETER	DIMENSION	DIMENSION	DIMENSION	ATTACHMENT PLATE THICKNESS	SIDE BOW	BREAKING LOAD
	p	b1 min.	d1 max.	A	B	D	E	C	G	F	R min.	FB min.
	mm	mm	mm	mm	mm	mm	mm	mm	mm	mm	mm	N
08 B-1 K7	12,7	7,75	8,50	24,00	8,90	4,30	12,90	18,90	12,70	1,50	400	18 690
10 B-1 K8	15,875	9,65	10,16	28,70	10,30	5,30	16,30	24,30	15,88	1,50	500	23 310

SIDE BOW ROLLER CHAINS WITH ONE SIDE EXTENDED PINS

ČZ Standard

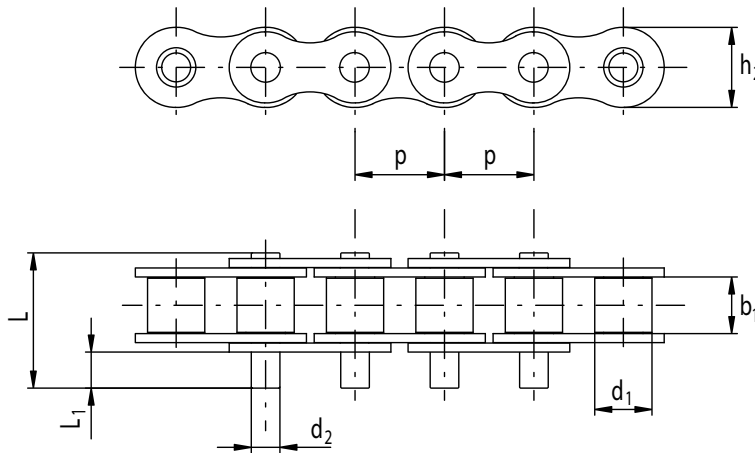
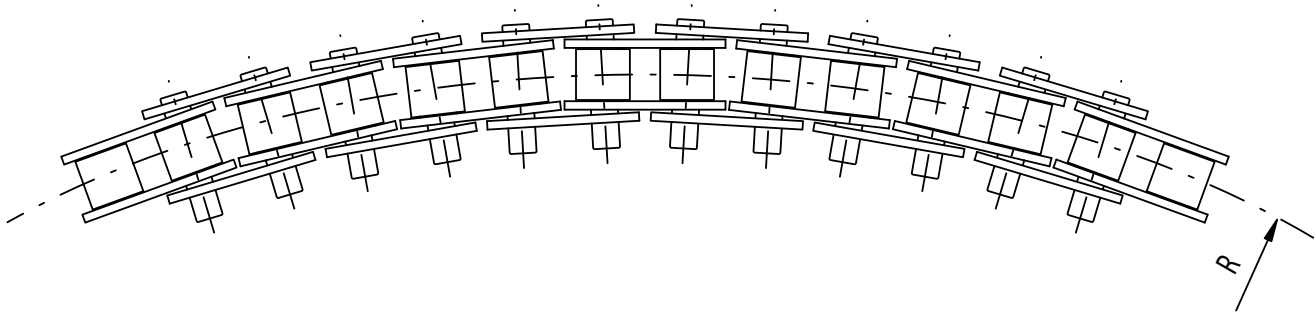

TRADE MARK ČZ	PITCH	INSIDE WIDTH	ROLLER DIAMETER	PIN DIAMETER	PIN LENGTH	PIN EXTENSION	INNER PLATE WIDTH	SIDE BOW	BREAKING LOAD
	p	b1 min.	d1 max.	d2 max.	L max.	L1 max.	h2 max.	R min.	FB min.
	mm	mm	mm	mm	mm	mm	mm	mm	N
08 B-1	12,7	7,75	8,51	4,45	21,20	5,40	11,60	370	18 690

SIDE BOW ROLLER CHAINS WITH BOTH SIDE EXTENDED PINS

ČZ Standard

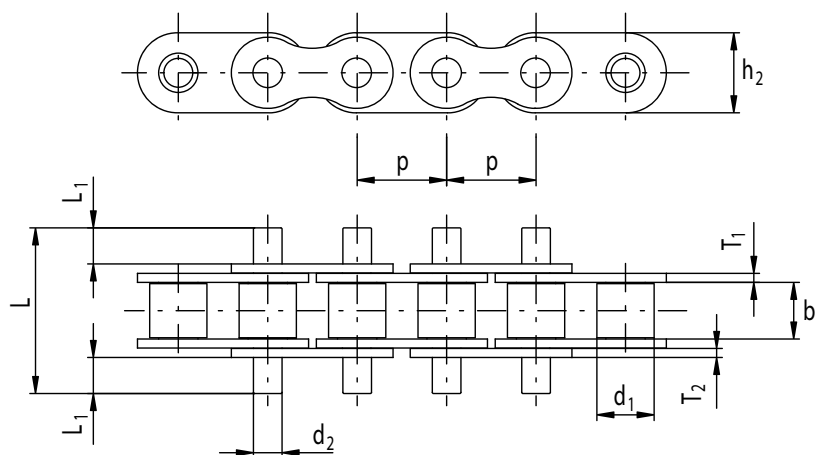
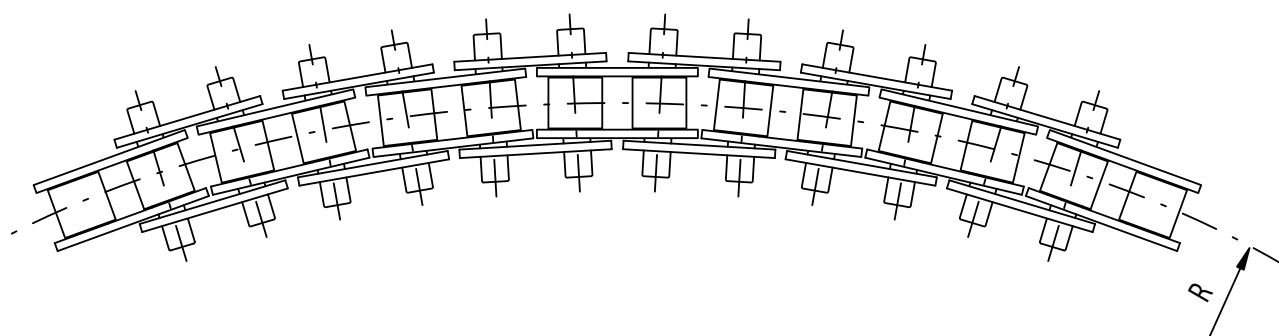

TRADE MARK ČZ	PITCH	INSIDE WIDTH	ROLLER DIAMETER	PIN DIAMETER	PIN LENGTH	PIN EXTENSION	INNER PLATE WIDTH	INNER PLATE THICKNESS	OUTER PLATE THICKNESS	SIDE BOW	BREAKING LOAD
	p	b1 min.	d1 max.	d2 max.	L max.	L1 max.	h2 max.	T1	T2	R min.	FB min.
	mm	mm	mm	mm	mm	mm	mm	mm	mm	mm	N
ASA 63	19,05	12,70	11,91	5,08	29,10	3,20	16,40	2,40	2,00	365	27 200

DUPLEX ROLLER CHAINS WITH U-TYPE ATTACHMENTS DUPLEX ROLLER CHAINS WITH U-TYPE RUBBER ATTACHMENTS

ČZ Standard

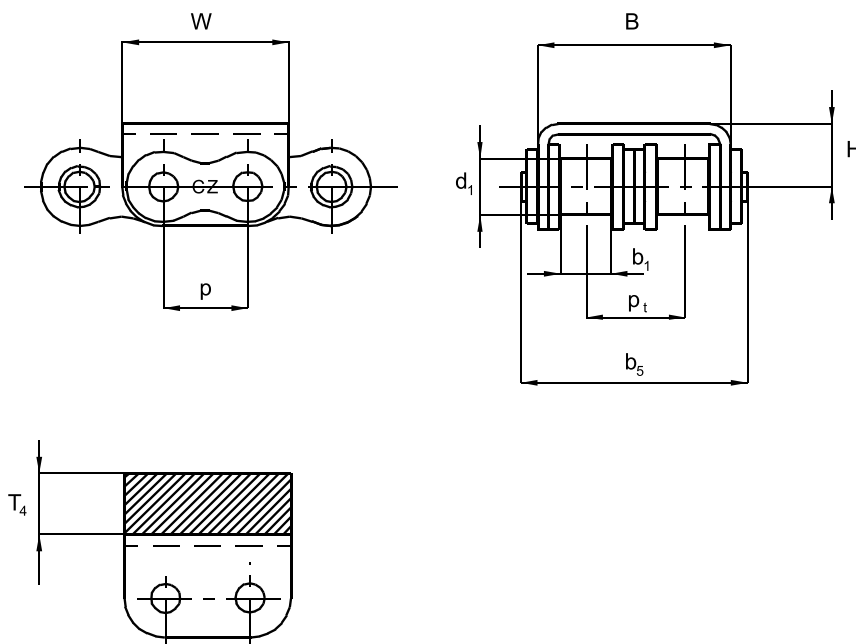

TRADE MARK ČZ	PITCH p	INSIDE WIDTH b1 min.	ROLLER DIAMETER d1 max.	PIN LENGTH b5 max.	PROFILE HEIGHT H	PROFILE WIDTH B	PROFILE LENGTH W	PLASTIC BLOCK THICKNESS T4	TRANSVER. PITCH pt	BREAKING LOAD FB min.	CONNECTING ELEMENTS	
											SPECIAL OUTER LINK	SPECIAL CONNECTING LINK WITH SAFETY CLIP
	mm	mm	mm	mm	mm	mm	mm	mm	mm	N		
08 B-2	12,7	7,75	8,51	33,60	8,90	27,60	24,30	-	13,92	32 655	•	•
12 B-2	19,05	11,68	12,07	45,50	13,45	39,00	35,00	-	19,46	60 690	•	•
12 B-2	19,05	11,68	12,07	45,50	13,45	39,00	35,00	13,50	19,46	60 690	•	•

Plastic type, mechanical properties and other possible requests must be consulted with producer
The U-Type attachment can be positioned on any other chain link - must be consulted with producer

TRIPLEX ROLLER CHAINS WITH U-TYPE ATTACHMENTS TRIPLEX ROLLER CHAINS WITH U-TYPE RUBBER ATTACHMENTS

ČZ Standard

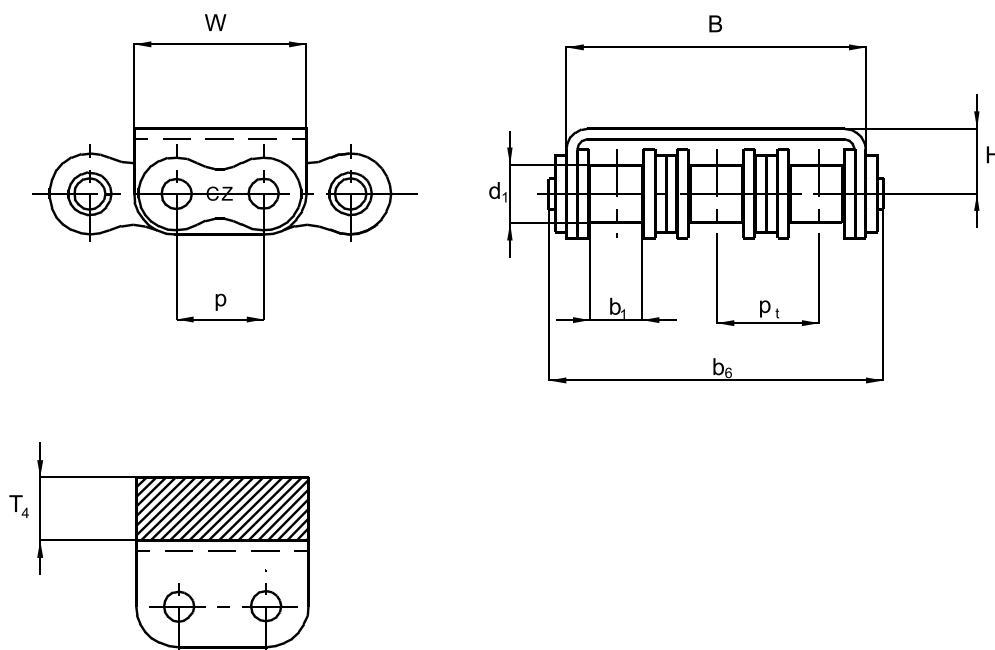

TRADE MARK ČZ	PITCH p	INSIDE WIDTH b1 min.	ROLLER DIAMETER d1 max.	PIN LENGTH b6 max.	PROFILE HEIGHT H	PROFILE WIDTH B	PROFILE LENGTH W	PLASTIC BLOCK THICKNESS T4	TRANSVER. PITCH pt	BREAKING LOAD FB min. N	CONNECTING ELEMENTS	
											SPECIAL OUTER LINK	SPECIAL CONNECTING LINK WITH SAFETY CLIP
08 B-3	12,7	7,75	8,51	48,60	10,00	43,40	24,20	-	13,92	46 725	•	•
08 B-3	12,7	7,75	8,51	48,60	10,00	43,40	24,20	5,50	13,92	46 725	•	•

Plastic type, mechanical properties and other possible requests must be consulted with producer
The U-Type attachment can be positioned on any other chain link - must be consulted with producer

6-ROW ROLLER CHAINS WITH U-TYPE ATTACHMENTS 6-ROW ROLLER CHAINS WITH U-TYPE RUBBER ATTACHMENTS

ČZ Standard

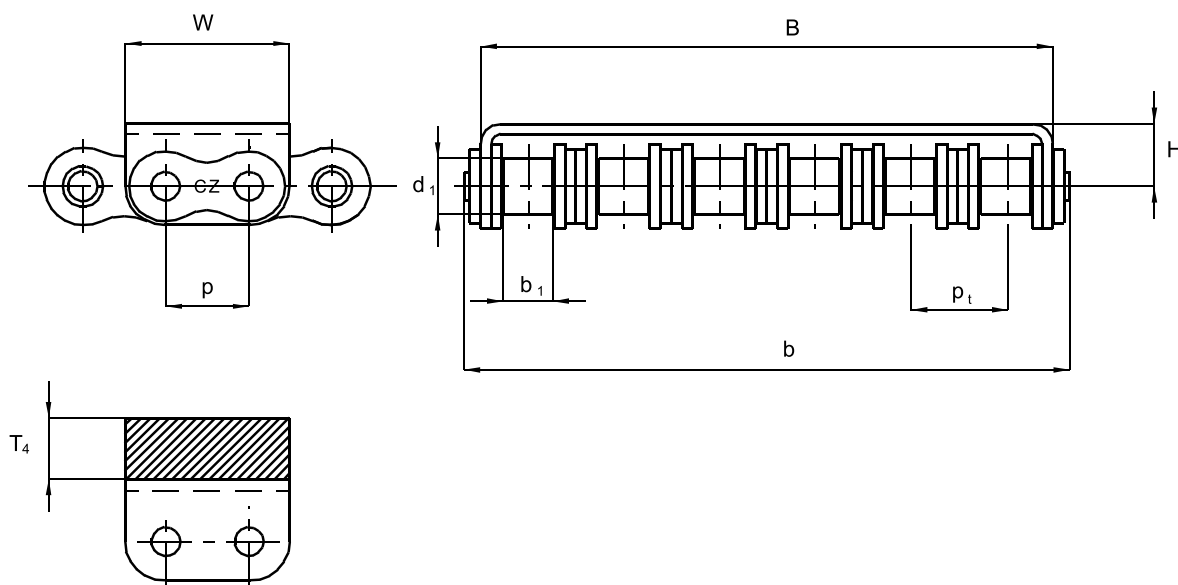

TRADE MARK ČZ	PITCH	INSIDE WIDTH	ROLLER DIAMETER	PIN LENGTH	PROFILE HEIGHT	PROFILE WIDTH	PROFILE LENGTH	PLASTIC BLOCK THICKNESS	TRANSVER. PITCH	BREAKING LOAD	CONNECTING ELEMENTS	
											SPECIAL OUTER LINK	SPECIAL CONNECTING LINK WITH SAFETY CLIP
	p	b1 min.	d1 max.	b max.	H	B	W	T4	pt	FB min.		
	mm	mm	mm	mm	mm	mm	mm	mm	mm	N		
08B-6	12,7	7,75	8,51	89,40	12,70	84,00	24,30	-	13,92	112 000	•	•
08B-6	12,7	7,75	8,51	89,40	12,70	84,00	24,30	2,80	13,92	112 000	•	•

Plastic type, mechanical properties and other possible requests must be consulted with producer
The U-Type attachment can be positioned on any other chain link - must be consulted with producer



CONVEYOR CHAINS WITH PLASTIC OR STEEL ROLLERS

Type C

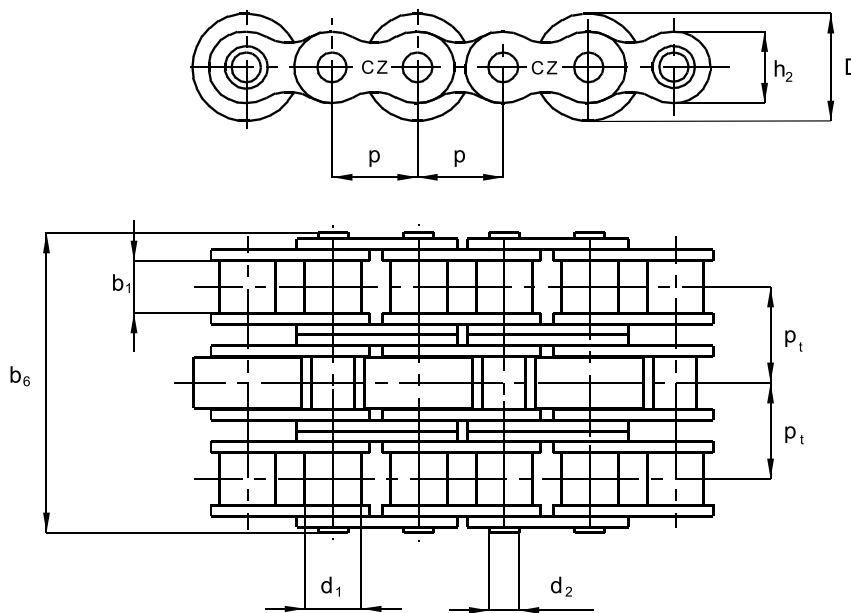

TRADE MARK ČZ	PITCH	INSIDE WIDTH	ROLLER DIAMETER	PIN DIAMETER	PIN LENGTH	INNER PLATE WIDTH	TRANSVER. PITCH	CONVEYOR ROLLER DIAMETER	CONVEYOR ROLLER MATERIAL	BREAKING LOAD	CONNECTING ELEMENTS			
											B	A	E	S
	p	b1 min.	d1 max.	d2 max.	b6 max.	h2 max.	Pt	D		FB min.				
	mm	mm	mm	mm	mm	mm	mm	mm		N				
06 B-3+	9,525	5,72	6,35	3,28	32,90	8,20	10,24	14,00	steel	26 145	•	•	•	
06 B-3+	9,525	5,72	6,35	3,28	32,90	8,20	10,24	14,00	plastic	26 145	•	•	•	•
10 B-3	15,875	9,65	10,16	5,08	51,90	14,50	16,59	20,00	steel	70 035	•	•	•	•

CONNECTING ELEMENTS

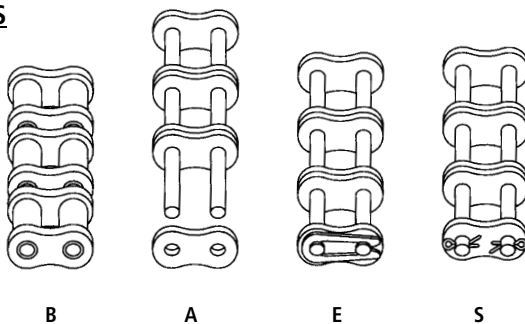

CONVEYOR CHAINS WITH PLASTIC OR STEEL ROLLERS

Type C

TRADE MARK ČZ	PITCH	INSIDE WIDTH	ROLLER DIAMETER	PIN DIAMETER	PIN LENGHT	INNER PLATE WIDTH	TRANSVER. PITCH	CONVEYOR ROLLER DIAMETER	CONVEYOR ROLLER MATERIAL	BREAKING LOAD	CONNECTING ELEMENTS			
											B	A	E	S
	p	b1 min.	d1 max.	d2 max.	b6 max.	h2 max.	Pt	D		FB min.				
	mm	mm	mm	mm	mm	mm	mm	mm		N				
10 B-3	15,875	9,65	10,16	5,08	51,90	14,50	16,59	20,00	plastic	70 035
10 B-3	15,875	9,65	10,16	5,08	51,90	14,50	16,59	18,00	steel	70 035
10 B-3	15,875	9,65	10,16	5,08	51,90	14,50	16,59	18,00	plastic	70 035
12 B-3	19,05	11,68	12,07	5,72	61,25	16,10	19,46	24,00	steel	91 035
12 B-3	19,05	11,68	12,07	5,72	61,25	16,10	19,46	24,00	Cast: PE-UHM PA 6.6 Vestamid L-R7-MHI PA 12	91 035
12 B-3	19,05	11,68	12,07	5,72	61,25	16,10	19,46	26,00	steel	91 035
12 B-3	19,05	11,68	12,07	5,72	61,25	16,10	19,46	28,00	steel	91 035
12 B-3	19,05	11,68	12,07	5,72	61,25	16,10	19,46	28,00	Cast: PE-UHM PA 6.6 Vestamid L-R7-MHI PA 12	91 035
16 B-3	25,4	17,02	15,88	8,28	99,10	21,00	31,88	38,50	steel	195 000
16 B-3	25,4	17,02	15,88	8,28	99,10	21,00	31,88	38,50	Cast: PE-UHM PA 6.6 Vestamid L-R7-MHI PA 12	195 000

+ONLY WITH ONE MEDDLE PLATE

Plastic type must be consulted with producer

Inner links with conveyor rollers are mostly in the middle row of the triplex chain. In case of customer request they can be positioned on the side chain rows - must be consulted with producer

Special request concerning the rollers position in the chain must be consulted with producer

SIMPLEX CONVEYOR CHAINS WITH SIDE TRANSPORTING ROLLERS

ČZ Standard



08 B

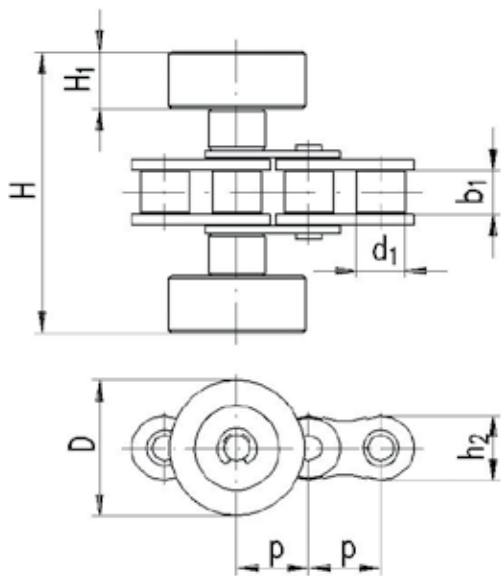

212 B

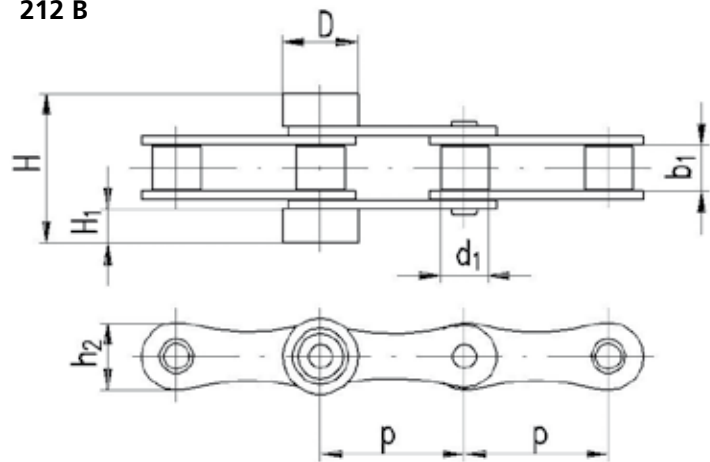

TRADE MARK ČZ	PITCH	INSIDE WIDTH	ROLLER DIAMETER	DIMENSION	INNER PLATE WIDTH	CONVEYOR ROLLER DIAMETER	CONVEYOR ROLLER HEIGHT	CONVEYOR ROLLER MATERIAL	BREAKING LOAD
	p	b1 min.	d1 max.	H	h2 max.	D	H1		FB min.
	mm	mm	mm	mm	mm	mm	mm		N
08 B	12,7	7,75	8,51	49,00	11,60	24,00	10,00	plastic	18 690
212 B	38,1	11,68	12,07	40,00	16,40	20,00	9,00	plastic	30 345

Transporting roller material must be consulted with producer
 Transporting roller position in the chain must be consulted with producer

The chain closing with disconnecting elements is possible only if the transporting rollers are not on every outer link. In opposite case is possible to close the chain only by special outer link - riveting connection

DUPLEX CONVEYOR CHAINS WITH ONE SIDE TRANSPORTING ROLLERS

ČZ Standard

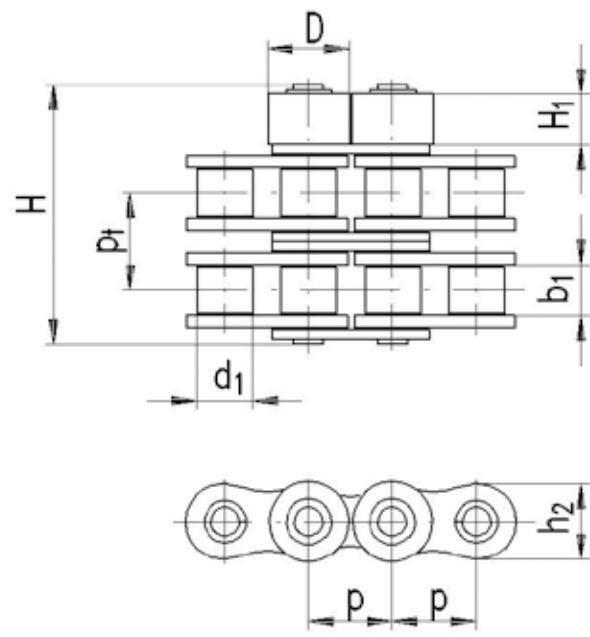
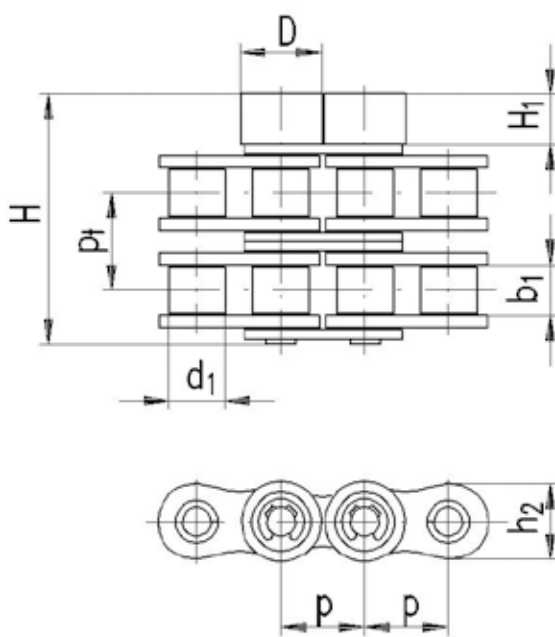

TRADE MARK ČZ	PITCH	INSIDE WIDTH	ROLLER DIAMETER	DIMENSION	INNER PLATE WIDTH	CONVEYOR ROLLER DIAMETER	CONVEYOR ROLLER HEIGHT	TRANSVER. PITCH	CONVEYOR ROLLER MATERIAL	BREAKING LOAD	CONNECTING ELEMENTS	
	p	b1 min.	d1 max.	H	h2 max.	D	H1	pt		FB min.	SPECIAL OUTER LINK	SPEC. CON. LINK WITH SAFETY SPRING
	mm	mm	mm	mm	mm	mm	mm	mm		N		
08 B-2	12,70	7,75	8,51	37,20	12,00	12,30	7,60	13,92	steel	32 655	•	•
12 B-2	19,05	11,68	12,07	55,00	16,40	18,00	11,60	19,46	steel	60 690	•	

It is necessary to consult with producer in case the transporting roller should not be on every pin

DUPLEX CONVEYOR CHAINS WITH MIDDLE TRANSPORTING ROLLERS

ČZ Standard

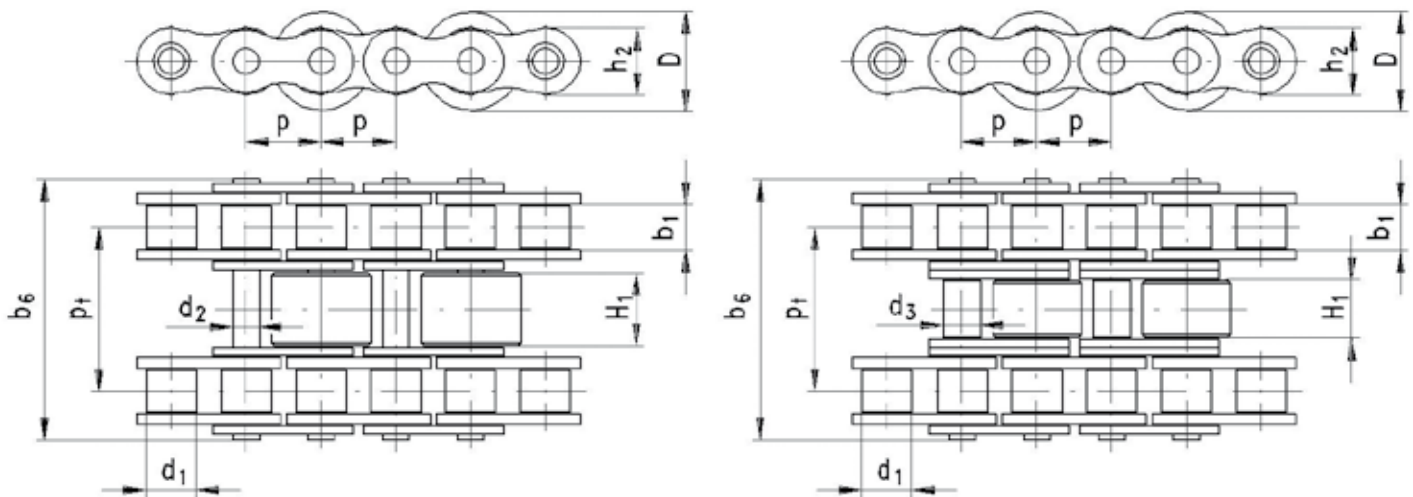

TRADE MARK ČZ	PITCH	INSIDE WIDTH	ROLLER DIAMETER	PIN DIAMETER	BUSH DIAMETER	DIMENSION	INNER PLATE WIDTH	CONVEYOR ROLLER DIAMETER	CONVEYOR ROLLER HEIGHT	TRANSVER. PITCH	CONVEYOR ROLLER MATERIAL	BREAKING LOAD	MODIFICATION	CONNECTING ELEMENTS	
														SPECIAL OUTER LINK	SPEC. CON. LINK WITH SAFETY SPRIG
	p	b1 min.	d1 max.	d2 max.	d3	b6	h2 max.	D	H1	pt		FB min.			
	mm	mm	mm	mm	mm	mm	mm	mm	mm	mm		N			
06 B	9,525	5,72	6,35	3,28	-	32,90	8,10	14,00	8,50	20,48	steel	17 745	"A"	•	•
08 B	12,7	7,75	8,51	4,45	-	44,25	11,60	17,00	12,50	27,84	steel	32 655	"A"	•	•
08 B	12,7	7,75	8,51	4,45	-	44,25	11,60	17,00	12,50	27,84	plastic	32 655	"A"	•	•
12 B	19,05	11,68	12,07	5,72	-	61,25	16,40	28,00	18,80	38,92	steel	60 690	"A"	•	•
12 B	19,05	11,68	12,07	-	8,00	61,25	16,40	28,00	15,60	38,92	steel	91 035	"B"	•	•

Material and position of transporting roller must be consulted with producer

SIMPLEX CONVEYOR CHAINS WITH TRANSPORTING ROLLERS ON THE UPPER ROW WITH SPECIAL ATTACHMENTS M2, M8

ČZ Standard

TYPE M2

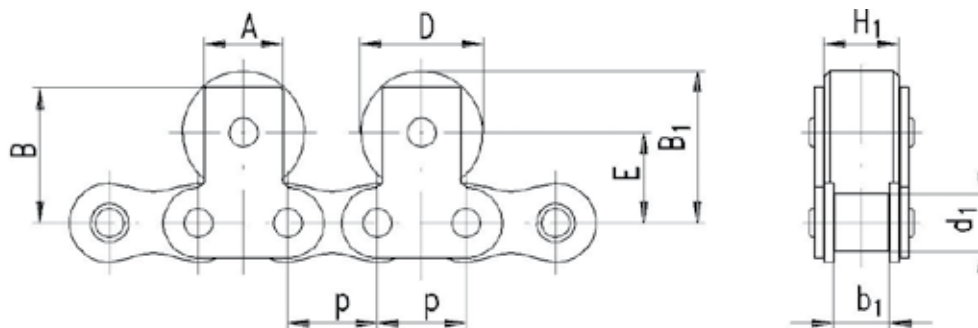

TYPE M8

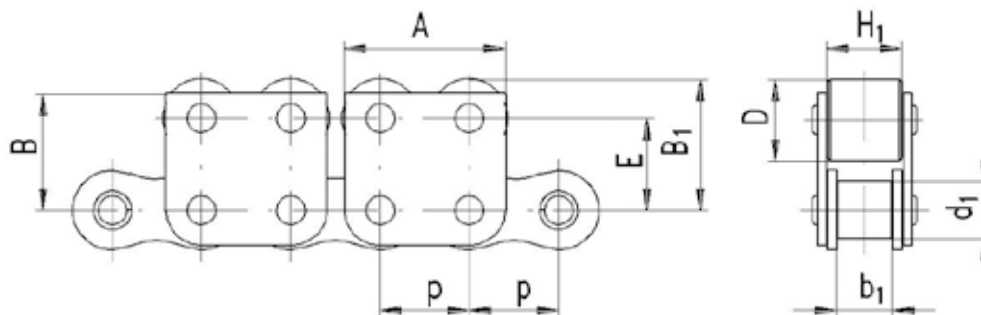

TRADE MARK ČZ	PITCH	INSIDE WIDTH	ROLLER DIAMETER	DIMENSION	DIMENSION	DIMENSION	CONVEYOR ROLLER DIAMETER	DIMENSION	CONVEYOR ROLLER HEIGHT	CONVEYOR ROLLER MATERIAL	BREAKING LOAD	ATTACHMENT TYPE	CONNECTING ELEMENTS		
													SPECIAL OUTER LINK	SPECIAL CONNECTING LINK WITH 2 SAFETY SPRINGS	Special con. link with safety spring and cotter
	p	b1 min.	d1 max.	A	B	B1	D	E	H1 max.		FB min.				
	mm	mm	mm	mm	mm	mm	mm	mm	mm		N				
06 B	9,525	5,72	6,35	17,80	12,30	13,60	9,00	9,10	8,50	steel	9 345	M2	•		•
10 B	15,875	9,65	10,16	14,00	24,00	27,70	22,00	16,70	13,20	steel	23 310	M2	•		•
10 B	15,875	9,65	13,25	28,70	20,85	23,25	14,00	16,25	13,25	steel	23 310	M8	•	•	

Transporting roller position with attachments type M2 or M8 must be consulted with producer

DUPLEX CONVEYOR CHAINS WITH TRANSPORTING ROLLERS ON THE UPPER ROW WITH SPECIAL ATTACHMENTS M8

ČZ Standard

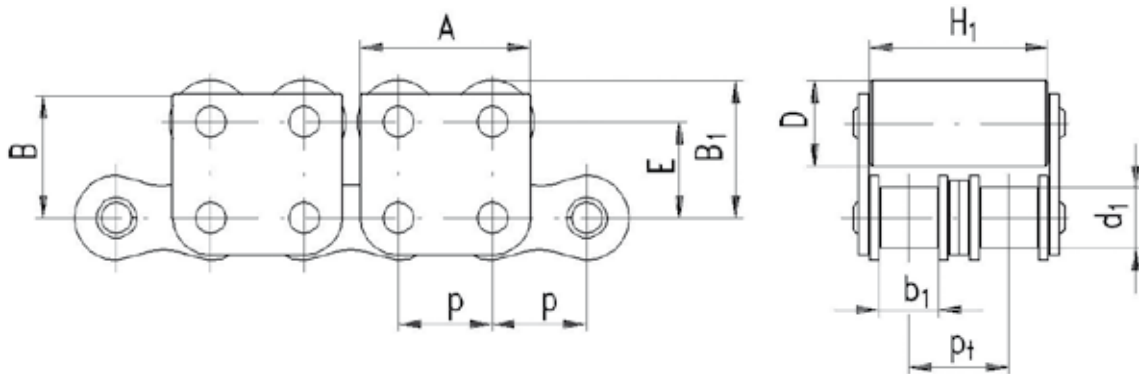

TRADE MARK ČZ	PITCH	INSIDE WIDTH	ROLLER DIAMETER	DIMENSION	DIMENSION	DIMENSION	CONVEYOR ROLLER DIAMETER	DIMENSION	CONVEYOR ROLLER HEIGHT	TRANSVER. PITCH	CONVEYOR ROLLER MATERIAL	BREAKING LOAD	CONNECTING ELEMENTS	
	p	b1 min.	d1 max.	A	B	B1	D	E	H1 max.	pt		FB min.	SPECIAL OUTER LINK	SPECIAL CONNECTING LINK WITH 2 SAFETY SPRINGS
	mm	mm	mm	mm	mm	mm	mm	mm	mm	mm		N		
08 B-2	12,7	7,75	8,51	24,00	17,40	18,90	11,80	13,00	25,20	13,92	steel	32 655	•	•

DOUBLE PITCH ATYPICAL ROLLER CHAINS

ČZ Standard

25,4 x 7,75 x 15,88

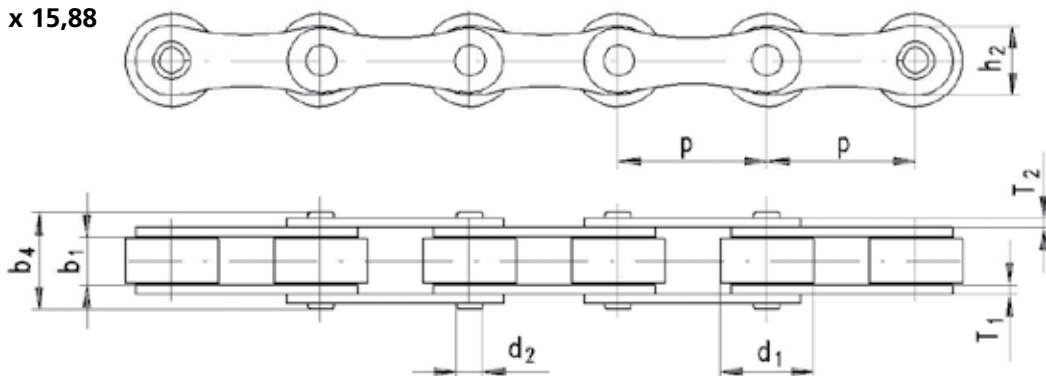

25,4 x 23,2 x 8,51

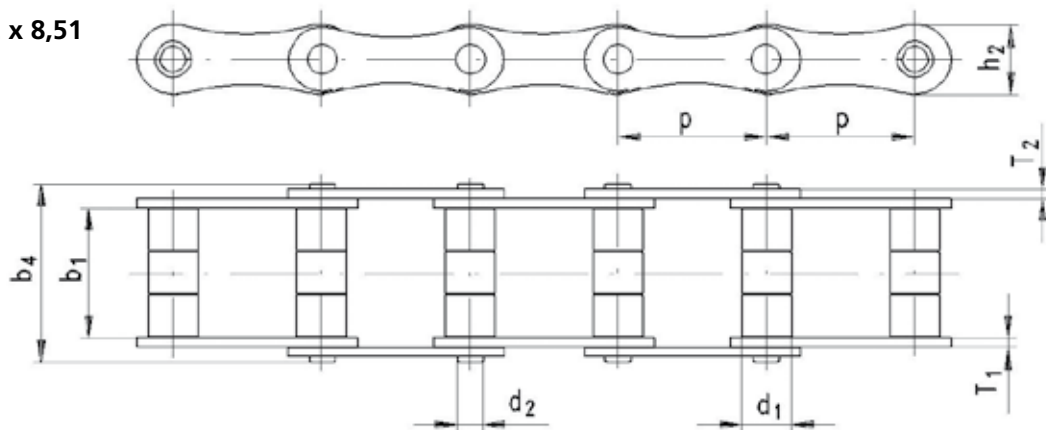

TRADE MARK ČZ	PITCH	INSIDE WIDTH	ROLLER DIAMETER	PIN DIAMETER	PIN LENGTH	INNER PLATE WIDTH	INNER PLATE THICKNESS	OUTER PLATE THICKNESS	WEIGHT	BREAKING LOAD	CONNECTING ELEMENTS		
											B	A	S
	p	b1 min.	d1 max.	d2 max.	b4 max.	h2 max.	T1	T2	q	FB min.			
	mm	mm	mm	mm	mm	mm	mm	mm	kg/m	N			
25,4x7,75x15,88	25,4	7,75	15,88	4,45	16,40	12,00	1,60	1,50	0,97	18 690	•	•	•
25,4x23,2x8,51	25,4	23,20	8,51	4,45	32,50	12,00	1,60	1,50	0,89	18 690	•	•	•

CONNECTING ELEMENTS

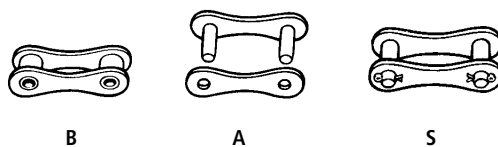

B

A

S



ATYPICAL ROLLER CHAINS

ČZ Standard

12,7 x 7,75 x 12,3

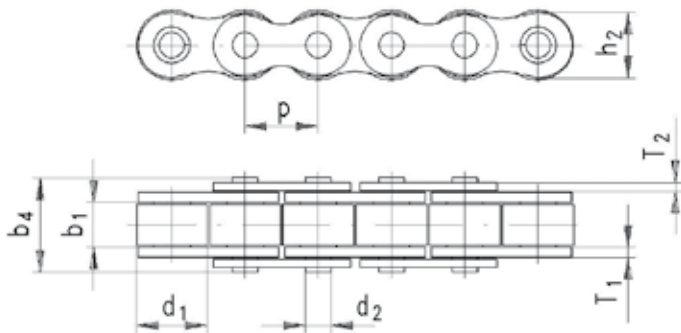

12,7 x 23,2 x 8,51

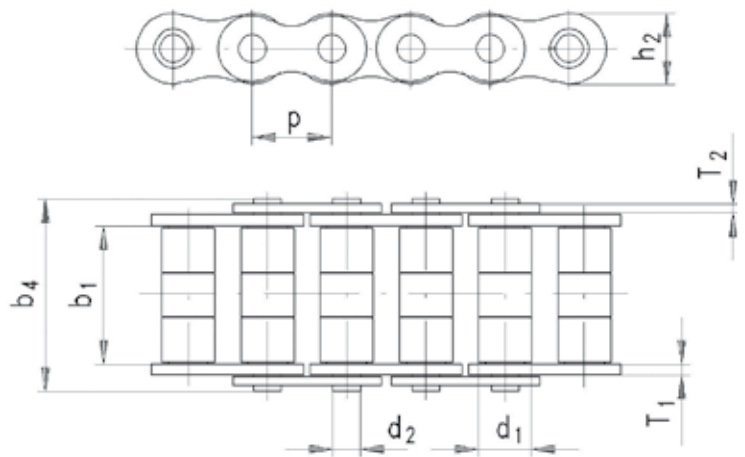

19,05 x 31,4 x 12

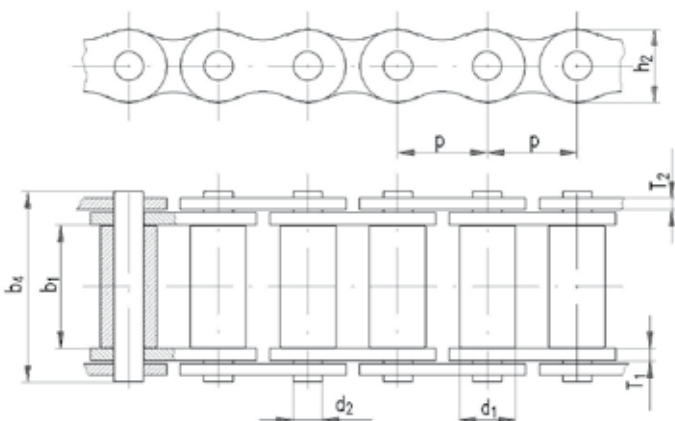

ATYPICAL ROLLER CHAINS

ČZ Standard

19,05 x 20,68 x 12,07
25,4 x 35 x 15,88

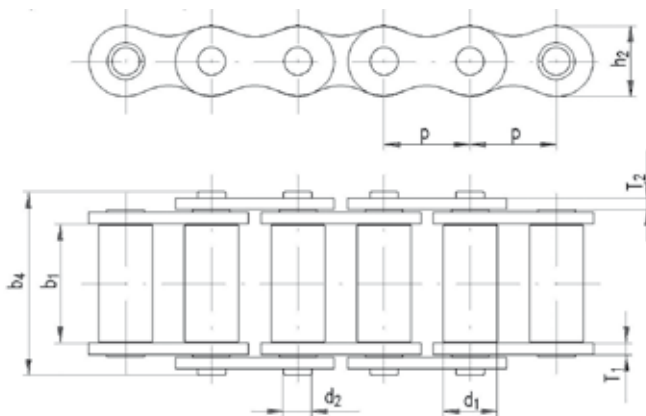

25,4 x 12,7 x 12,7

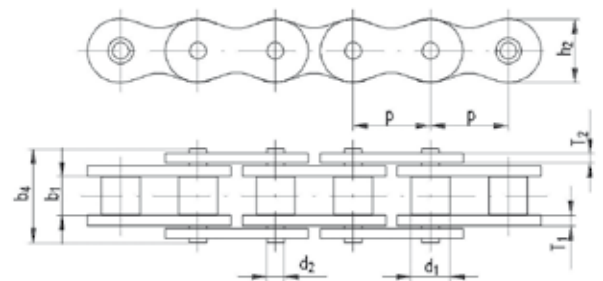

TRADE MARK ČZ	PITCH	INSIDE WIDTH	ROLLER DIAMETER	PIN DIAMETER	PIN LENGHT	INNER PLATE WIDTH	INNER PLATE THICKNESS	OUTER PLATE THICKNESS	WEIGHT	BREAKING LOAD	CONNECTING ELEMENTS			
											B	A	E	S
	p	b1 min.	d1 max.	d2 max.	b4 max.	h2 max.	T1	T2	q	FB min.				
	mm	mm	mm	mm	mm	mm	mm	mm	kg/m	N				
12,7 x 7,75 x 12,3	12,7	7,75	12,30	4,45	16,40	11,80	1,60	1,40	1,01	18 690	•	•	•	•
12,7 x 23,2 x 8,51	12,7	23,20	8,51	4,45	32,50	11,80	1,60	1,40	1,24	18 690	•	•	•	
19,05 x 31,4 x 12	19,05	31,40	12,00	5,72	41,70	16,10	1,80	1,80	3,25	30 345		•		
19,05 x 20,68 x 12,07	19,05	20,68	12,07	5,72	31,00	16,10	1,80	1,80	1,68	30 345	•	•	•	
25,4 x 35 x 15,88	25,4	35,00	15,88	8,28	54,00	21,00	3,50	3,00	3,80	75 000	•	•	•	
25,4 x 12,7 x 12,7	25,4	12,70	12,70	5,94	28,85	19,40	3,00	3,00	3,08	40 000	•	•		

CONNECTING ELEMENTS



B

A

E

S

LEAF CHAINS

According to standards ISO, DIN, ANSI, ČZ

LEAF CHAINS

light series LL according to standard ISO, DIN.....	106
LEAF CHAINS - heavy series LH (=BL) according to standard ČZ	107
LEAF CHAINS - light series LL according to standard ČZ	108–109
LEAF CHAINS - heavy series LH (=BL) according to standard ISO, ANSI	110–111
LEAF CHAINS - AL series according to standard ČZ	112–113
LEAF CHAINS according to standard ČZ	114–115
LEAF CHAINS accessories - end plates	116
LEAF CHAINS accessories - pins for cotter	117–118
LEAF CHAINS accessories - holders	119–120

LEAF CHAINS

***- are used mainly for heavy load handling
on reasonable lifting machines***

***Applications: fork lift trucks,
lifting and tensioning equipment***

Leaf chains are different from so far mentioned chains not only in their design but also in their function. These chains are bearing chains used for changing of power direction. They are used for lifting, tensioning, holding of counterbalances, etc. They cannot be used like drive chains. They are more wear resistant and heavier in comparison with previous chains.

Outer plates (a) are tightly pressed on pins (b) and pins are rivetted like at roller or bush chains.

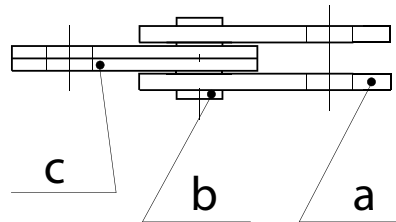

Leaf chain

Connecting plates (c) are freely pivoted on pins and can be assembled in various combinations according to transferred power. Chains with bushes are used for longer durability of leaf chains.





LEAF CHAINS

Light series LL according to standard ISO, DIN

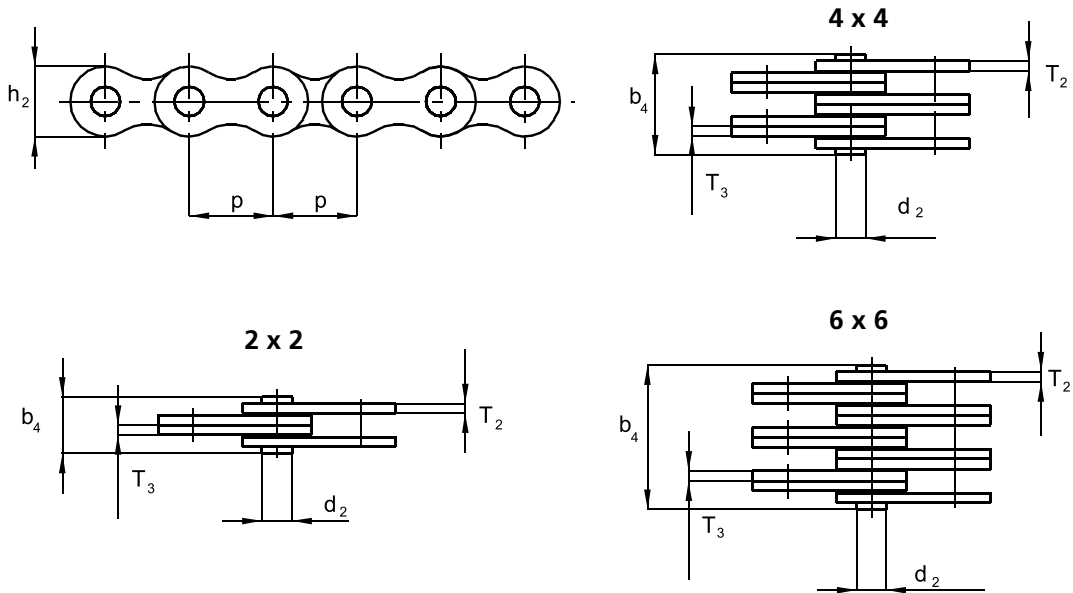

ISO DIN	NOMINAL PITCH	PLATE COMBINATION	PIN DIAMETER	PIN LENGHT	INNER PLATE WIDTH	OUTER PLATE THICKNESS	CONNECT. PLATE THICKNESS	WEIGHT	BREAKING LOAD
	p		d ₂ max.	b ₄ max.	h ₂ max.	T ₂	T ₃	q	FB min.
	mm		mm	mm	mm	mm	mm	kg/m	N
LL 0822	12,7	2 x 2	4,45	8,80	10,90	1,40	1,50	0,40	18 000
LL 0844	12,7	4 x 4	4,45	15,20	10,90	1,40	1,50	0,74	36 000
LL 0866	12,7	6 x 6	4,45	21,60	10,90	1,40	1,50	1,10	64 000
LL 1022	15,875	2 x 2	5,08	9,60	12,90	1,60	1,60	0,47	24 600
LL 1044	15,875	4 x 4	5,08	16,20	12,90	1,60	1,60	0,92	49 500
LL 1066	15,875	6 x 6	5,08	23,60	12,90	1,60	1,60	1,63	74 000
LL 1222	19,05	2 x 2	5,72	10,40	15,10	1,80	1,80	0,63	31 000
LL 1244	19,05	4 x 4	5,72	18,00	15,10	1,80	1,80	1,29	62 000
LL 1266	19,05	6 x 6	5,72	25,60	15,10	1,80	1,80	1,85	93 000
LL 1622	25,4	2 x 2	8,28	17,80	19,40	3,12	3,00	1,42	63 000
LL 1644	25,4	4 x 4	8,28	30,20	19,40	3,12	3,00	2,75	127 000
LL 1666	25,4	6 x 6	8,28	42,90	19,40	3,12	3,00	4,08	195 000

LEAF CHAINS

Heavy series LH and BL according to ČZ Standard

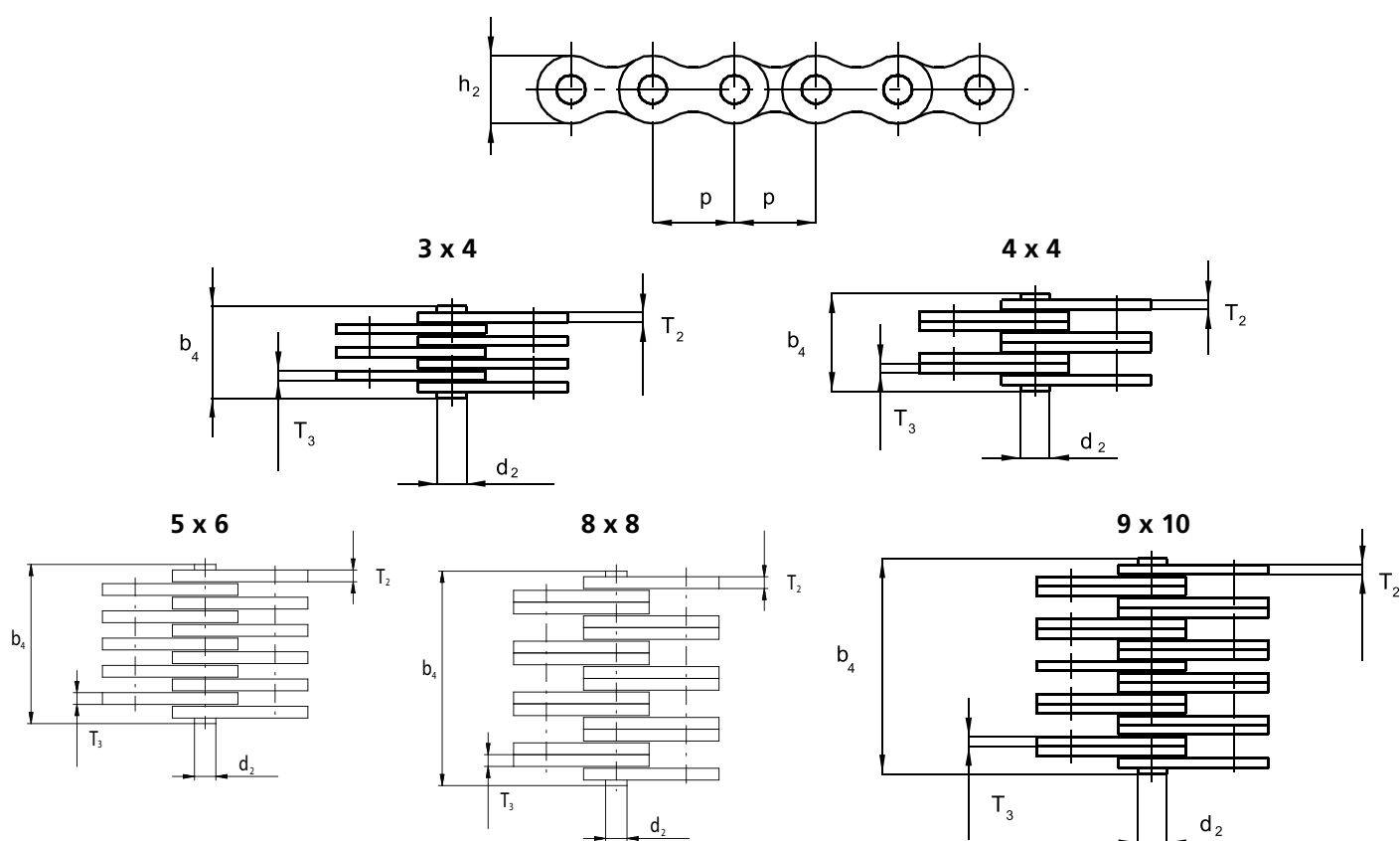

TRADE MARK ČZ	TRADE MARK ČZ	NOMINAL PITCH	PLATE COMBINATION	PIN DIAMETER	PIN LENGHT	INNER PLATE WIDTH	OUTER PLATE THICKNESS	CONNECT. PLATE THICKNESS	WEIGHT	BREAKING LOAD
		p		d2 max.	b4 max.	h2 max.	T2	T3	q	FB min.
		mm		mm	mm	mm	mm	mm	kg/m	N
LH 0834	BL 434	12,7	3 x 4	5,08	17,10	11,60	2,00	2,00	0,97	38 000
LH 0856	BL 456	12,7	5 x 6	5,08	25,70	11,60	2,00	2,00	1,52	59 000
LH 08-9-10	BL 4-9-10	12,7	9 x 10	5,08	41,80	11,60	2,00	2,00	2,59	115 000
LH 1044	BL 544	15,92	4 x 4	5,94	22,60	15,08	2,40	2,40	1,78	68 000
LH 1088	BL 588	15,875	8 x 8	5,94	42,60	15,08	2,40	2,40	3,53	136 000
LH 1288	BL 688	19,05	8 x 8	7,92	56,10	18,10	3,20	3,20	5,70	252 000
LH 1688	BL 888	25,4	8 x 8	9,53	69,60	24,00	4,00	4,00	10,08	338 000

Combining of plates is possible according to customer's request



LEAF CHAINS

Light series LL according to ČZ Standard

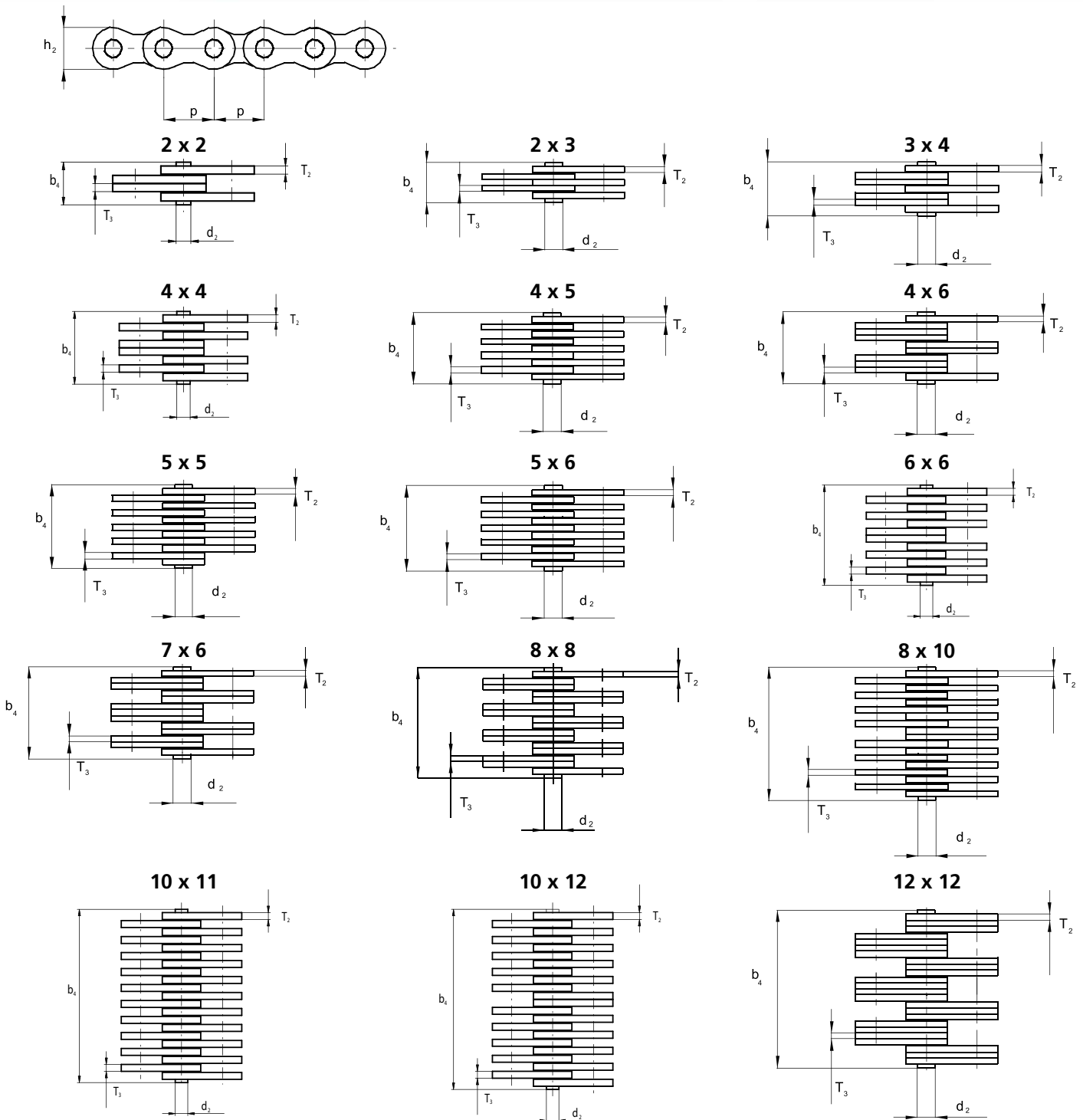

TRADE MARK ČZ	NOMINAL PITCH	PLATE COMBINATION	PIN DIAMETER	PIN LENGHT	INNER PLATE WIDTH	OUTER PLATE THICKNESS	CONNECT. PLATE THICKNESS	WEIGHT	BREAKING LOAD
	p		d2 max.	b4 max.	h2 max.	T2	T3	q	FB min.
	mm		mm	mm	mm	mm	mm	kg/m	N
LL 0823	12,7	2 x 3	4,45	10,45	10,90	1,40	1,50	0,51	18 000
LL 0834	12,7	3 x 4	4,45	13,65	10,90	1,40	1,50	0,66	27 000
LL 0844	12,7	4 x 4	4,45	15,20	10,90	1,40	1,50	0,74	36 000
LL 0845	12,7	4 x 5	4,45	16,70	10,90	1,40	1,50	0,87	36 000
LL 0846	12,7	4 x 6	4,45	18,20	10,90	1,40	1,50	0,92	45 000
LL 0856	12,7	5 x 6	4,45	20,05	10,90	1,40	1,50	1,02	57 000
LL 0866	12,7	6 x 6	4,45	21,60	10,90	1,40	1,50	1,10	64 000
LL 0888	12,7	8 x 8	4,45	28,00	10,90	1,40	1,50	1,47	72 000
LL 1023	15,875	2 x 3	5,08	11,40	12,90	1,60	1,60	0,58	24 600
LL 1034	15,875	3 x 4	5,08	14,90	12,90	1,60	1,60	0,80	37 000
LL 1044	15,875	4 x 4	5,08	16,20	12,90	1,60	1,60	0,93	49 500
LL 1045	15,875	4 x 5	5,08	18,40	12,90	1,60	1,60	1,22	49 500
LL 1055	15,875	5 x 5	5,08	20,10	12,90	1,60	1,60	1,16	49 500
LL 1056	15,875	5 x 6	5,08	21,90	12,90	1,60	1,60	1,25	62 000
LL 1066	15,875	6 x 6	5,08	23,60	12,90	1,60	1,60	1,63	74 000
LL 1076	15,875	7 x 6	5,08	25,30	12,90	1,60	1,60	1,40	80 400
LL 1088	15,875	8 x 8	5,08	26,80	12,90	1,60	1,60	1,85	99 000
LL 1223	19,05	2 x 3	5,72	12,35	15,10	1,80	1,80	0,79	31 000
LL 1234	19,05	3 x 4	5,72	16,15	15,10	1,80	1,80	1,09	46 500
LL 1244	19,05	4 x 4	5,72	18,00	15,10	1,80	1,80	1,29	62 000
LL 1245	19,05	4 x 5	5,72	19,85	15,10	1,80	1,80	1,39	62 000
LL 1246	19,05	4 x 6	5,72	21,50	15,10	1,80	1,80	1,54	62 000
LL 1256	19,05	5 x 6	5,72	23,75	15,10	1,80	1,80	1,70	77 500
LL 1266	19,05	6 x 6	5,72	25,60	15,10	1,80	1,80	1,85	93 000
LL 1288	19,05	8 x 8	5,72	33,20	15,10	1,80	1,80	2,46	124 000
LL 12-8-10	19,05	8 x 10	5,72	37,40	15,10	1,80	1,80	2,79	130 000
LL 12-10-12	19,05	10 x 12	5,72	44,30	15,10	1,80	1,80	3,36	150 000
LL 12-12-12	19,05	12 x 12	5,72	47,65	15,10	1,80	1,80	3,66	120 000
LL 1622 spec.	25,4	2 x 2	8,28	17,20	19,40	3,12	3,00	1,38	70 000
LL 1623	25,4	2 x 3	8,28	20,90	19,40	3,12	3,00	1,75	79 000
LL 1634	25,4	3 x 4	8,28	27,20	19,40	3,12	3,00	2,42	111 000
LL 1644	25,4	4 x 4	8,28	30,20	19,40	3,12	3,00	2,75	127 000
LL 1645	25,4	4 x 5	8,28	33,50	19,40	3,12	3,00	3,05	127 000
LL 1646	25,4	4 x 6	8,28	36,60	19,40	3,12	3,00	3,40	151 000
LL 1656	25,4	5 x 6	8,28	39,80	19,40	3,12	3,00	3,75	175 000
LL 1676	25,4	7 x 6	8,28	46,20	19,40	3,12	3,00	4,40	205 400
LL 1688	25,4	8 x 8	8,28	55,60	19,40	3,12	3,00	5,40	250 000
LL 16-10-11	25,4	10 x 11	8,28	71,80	19,40	3,12	3,00	7,10	300 000

Combining of plates is possible according to customer's request

LEAF CHAINS

Heavy series LH according to ISO 4347
Heavy series BL according to ANSI B29.8

ISO DIN	ANSI	NOMINAL PITCH	PLATE COMBINATION	PIN DIAMETER	PIN LENGTH	INNER PLATE WIDTH	OUTER PLATE THICKNESS	CONNECT. PLATE THICKNESS	WEIGHT	BREAKING LOAD
		p		d2 max.	b4 max.	h2 max.	T2	T3	q	FB min.
		mm		mm	mm	mm	mm	mm	kg/m	N
LH 0822	BL 422	12,7	2x2	5,08	11,00	11,60	2,00	2,00	0,57	24 200
LH 0844	BL 434	12,7	3x4	5,08	17,10	11,60	2,00	2,00	0,97	38 000
LH 0844	BL 444	12,7	4x4	5,08	19,40	11,60	2,00	2,00	1,11	51 000
LH 0846	BL 446	12,7	4x6	5,08	23,60	11,60	2,00	2,00	1,36	51 000
LH 0866	BL 466	12,7	6x6	5,08	27,20	11,60	2,00	2,00	1,64	66 600
LH 1022	BL 522	15,875	2x2	5,94	12,60	15,08	2,40	2,40	0,91	33 400
LH 1023	BL 523	15,875	2x3	5,94	15,30	15,08	2,40	2,40	1,56	33 400
LH 1034	BL 534	15,875	3x4	5,94	19,90	15,08	2,40	2,40	1,64	59 000
LH 1044	BL 544	15,875	4x4	5,94	22,60	15,08	2,40	2,40	1,78	68 000
LH 1046	BL 546	15,875	4x6	5,94	27,40	15,08	2,40	2,40	2,10	68 000
LH 1066	BL 566	15,875	6x6	5,94	32,60	15,08	2,40	2,40	2,64	102 000
LH 1222	BL 622	19,05	2x2	7,92	16,70	18,10	3,20	3,20	1,55	60 000
LH 1223	BL 623	19,05	2x3	7,92	20,00	18,10	3,20	3,20	1,83	60 000
LH 1234	BL 634	19,05	3x4	7,92	26,30	18,10	3,20	3,20	2,49	101 500
LH 1244	BL 644	19,05	4x4	7,92	29,60	18,10	3,20	3,20	2,90	116 000
LH 1246	BL 646	19,05	4x6	7,92	36,50	18,10	3,20	3,20	3,59	126 000
LH 1266	BL 666	19,05	6x6	7,92	44,20	18,10	3,20	3,20	4,32	190 000
LH 1622	BL 822	25,4	2x2	9,53	20,40	24,00	4,00	4,00	2,60	100 000
LH 1623	BL 823	25,4	2x3	9,53	24,50	24,00	4,00	4,00	3,23	100 000
LH 1634	BL 834	25,4	3x4	9,53	32,60	24,00	4,00	4,00	4,46	160 000
LH 1644	BL 844	25,4	4x4	9,53	36,80	24,00	4,00	4,00	5,09	200 000
LH 1646	BL 846	25,4	4x6	9,53	44,80	24,00	4,00	4,00	5,26	200 000
LH 1666	BL 866	25,4	6x6	9,53	53,20	24,00	4,00	4,00	8,12	285 000

LEAF CHAINS

Heavy series LH according to ISO 4347
Heavy series BL according to ANSI B29.8

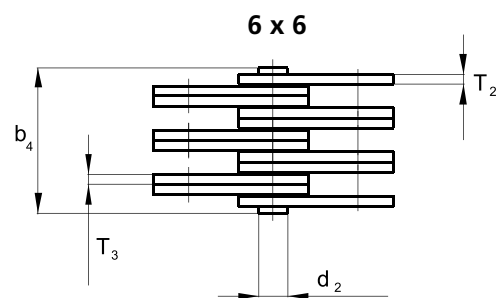
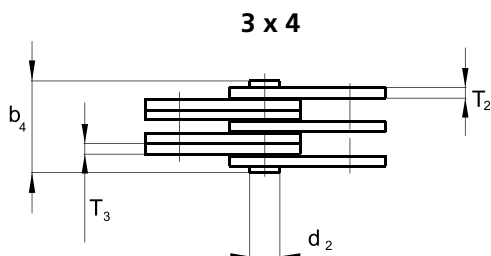
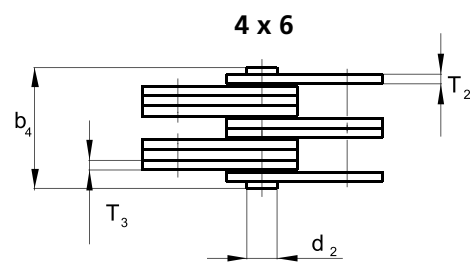
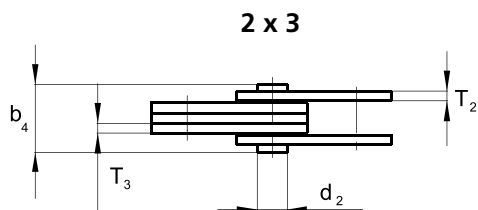
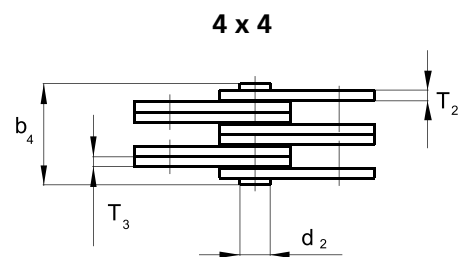
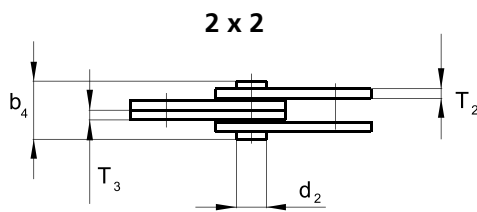
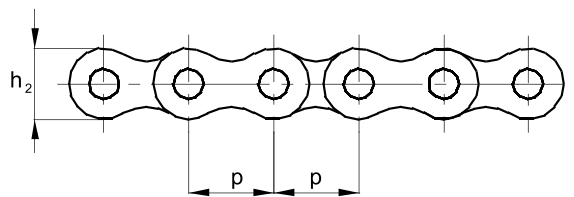

LEAF CHAINS

Series AL according to ČZ Standard

TRADE MARK ČZ	NOMINAL PITCH	PLATE COMBINATION	PIN DIAMETER	PIN LENGHT	INNER PLATE WIDTH	OUTER PLATE THICKNESS	CONNECT. PLATE THICKNESS	WEIGHT	BREAKING LOAD
	p		d2 max.	b4 max.	h2 max.	T2	T3	q	FB min.
	mm		mm	mm	mm	mm	mm	kg/m	N
AL 466	12,7	6 x 6	3,96	22,20	10,90	1,50	1,50	1,26	48 000
AL 423 H	12,7	2 x 3	5,08	13,10	10,90	2,00	2,00	0,7	30 000
AL 522	15,875	2 x 2	5,08	11,00	12,90	2,00	2,00	0,61	27 200
AL 522 spec.	15,875	2 x 2	5,08	20,20	12,90	2,00	2,00	0,69	27 200
AL 523	15,875	2 x 3	5,08	13,10	12,90	2,00	2,00	0,75	31 200
AL 534	15,875	3 x 4	5,08	14,80	12,90	2,00	2,00	1,04	43 700
AL 544	15,875	4 x 4	5,08	19,40	12,90	2,00	2,00	1,18	57 000
AL 566	15,875	6 x 6	5,08	27,20	12,90	2,00	2,00	1,78	90 000
AL 588	15,875	8 x 8	5,08	35,30	12,90	2,00	2,00	2,56	117 500
AL 622	19,05	2 x 2	5,94	12,60	15,70	2,40	2,40	0,88	40 000
AL 623	19,05	2 x 3	5,94	15,10	15,70	2,40	2,40	1,09	40 000
AL 634	19,05	3 x 4	5,94	19,90	15,70	2,40	2,40	1,51	65 000
AL 644	19,05	4 x 4	5,94	22,60	15,70	2,40	2,40	1,51	80 000
AL 646	19,05	4 x 6	5,94	27,40	15,70	2,40	2,40	2,15	80 000
AL 666	19,05	6 x 6	5,94	32,60	15,70	2,40	2,40	2,58	120 900
AL 688	19,05	8 x 8	5,94	42,60	15,70	2,40	2,40	3,91	133 400

Combining of plates is possible according to customer's request

LEAF CHAINS

Series AL according to ČZ Standard

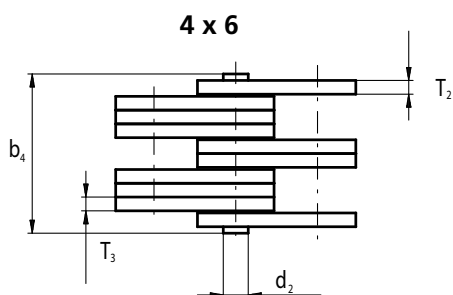
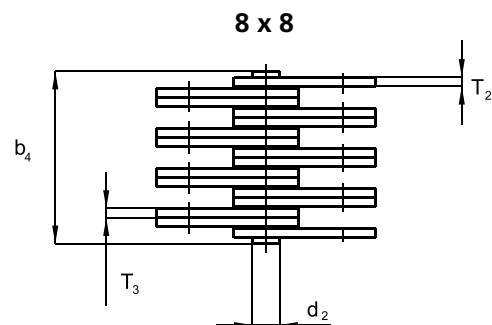
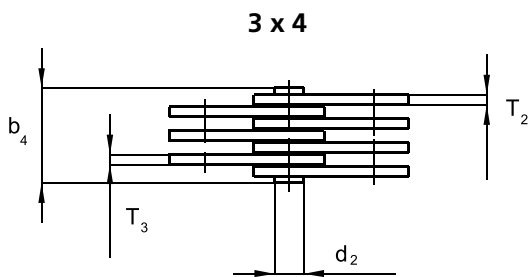
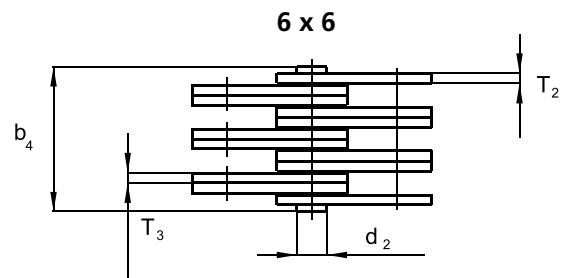
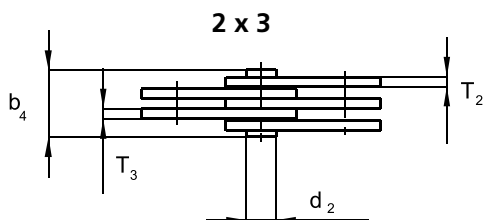
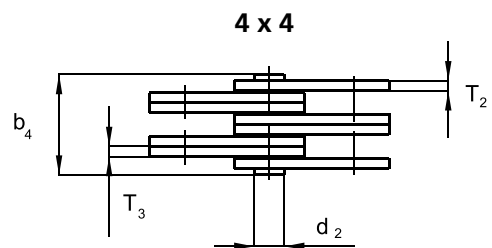
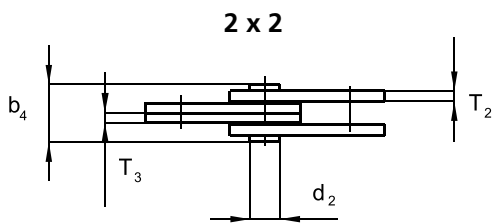
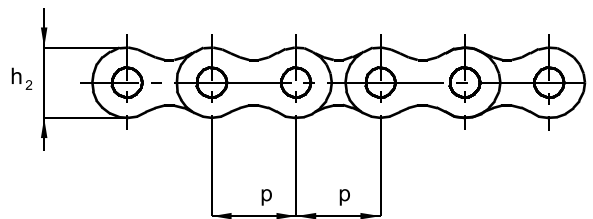

LEAF CHAINS

ČZ Standard

TRADE MARK ČZ	NOMINAL PITCH	PLATE COMBINATION	PIN DIAMETER	PIN LENGHT	INNER PLATE WIDTH	OUTER PLATE THICKNESS	CONNECT. PLATE THICKNESS	WEIGHT	BREAKING LOAD
	p		d2 max.	b4 max.	h2 max.	T2	T3	q	FB min.
	mm		mm	mm	mm	mm	mm	kg/m	N
05 B 2x2	8,0	2 x 2	2,31	5,60	6,20	0,80	0,80	0,12	4 600
05 B 4x4	8,0	4 x 4	2,31	9,20	6,20	0,80	0,80	0,24	8 000
05 B 2x3 STRONG	8,0	2 x 3	2,31	8,60	6,20	1,20	1,20	0,21	8 250
06 B 2x2*	9,525	2 x 2	3,28	6,70	8,20	1,00	1,20	0,26	9 500
06 B 4x4*	9,525	4 x 4	3,28	12,40	8,20	1,00	1,20	0,53	16 400
06 B 4x5*	9,525	4 x 5	3,28	13,50	8,20	1,00	1,20	0,60	18 590
06 B 5 x 6*	9,525	5 x 6	3,28	16,30	8,10	1,00	1,20	0,71	24 100
06 B 6 x 6*	9,525	6 x 6	3,28	17,60	8,20	1,00	1,20	0,80	26 500
06 B 6 x 6* LP	9,525	6 x 6	3,28	14,80	8,20	1,00	1,00	0,66	22 000
06 B 2x3 STRONG*	9,525	2 x 3	3,28	9,65	8,20	1,20	1,50	0,42	12 000
06 B 4x5 STRONG*	9,525	4 x 5	3,28	15,40	8,20	1,20	1,50	0,50	21 400
06 B 5x6 STRONG*	9,525	5 x 6	3,28	18,60	8,20	1,20	1,50	0,59	26 100
UF 944	9,525	4 x 4	3,58	12,00	7,60	1,20	1,20	0,47	22 000
UF 966	9,525	6 x 6	3,58	17,60	7,60	1,20	1,20	0,78	33 000
UF 988	9,525	8 x 8	3,58	23,00	7,60	1,20	1,20	0,97	41 300
08 B 2 x 2 STRONG	12,7	2 x 2	4,45	11,00	10,90	2,00	2,00	0,53	20 000
08 B 2 x 3 STRONG	12,7	2 x 3	4,45	13,10	10,90	2,00	2,00	0,66	20 000
08 B 3x4 STRONG	12,7	3 x 4	4,45	17,00	10,90	2,00	2,00	1,06	32 000
F 19V - 44	19,05	4 x 4	6,50	22,60	15,70	2,40	2,40	1,74	71 000
F 19V - 66	19,05	6 x 6	6,50	32,60	15,70	2,40	2,40	2,58	106 000

*Only with straight plates

LEAF CHAINS

ČZ Standard

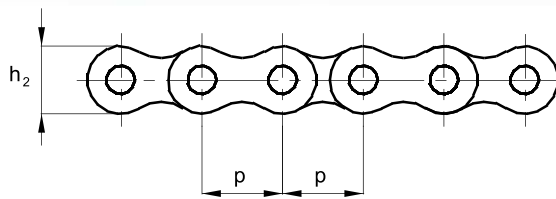

2 x 2

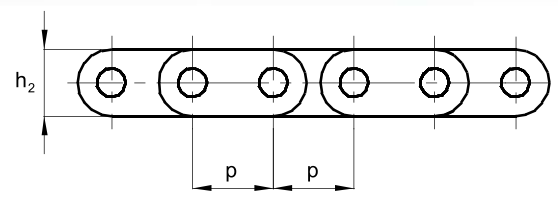

4 x 5

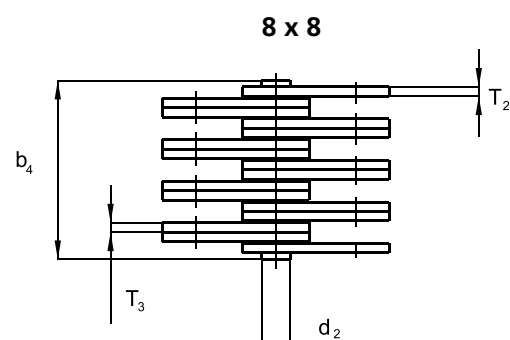
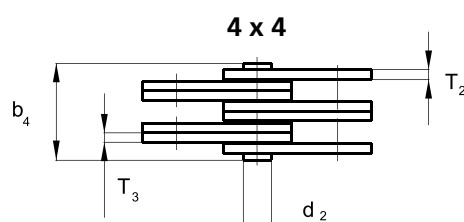
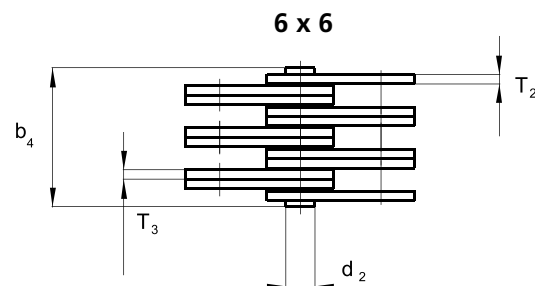
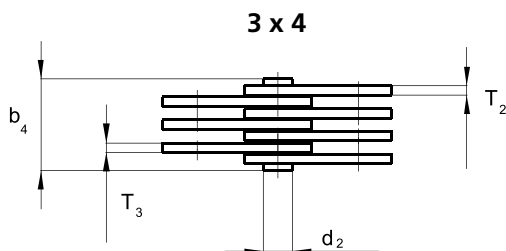
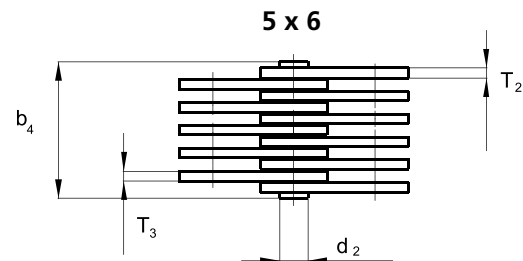
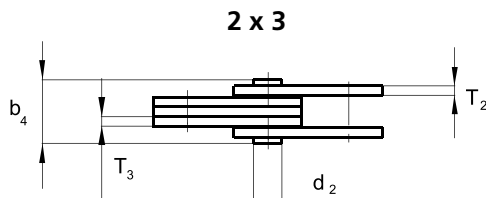
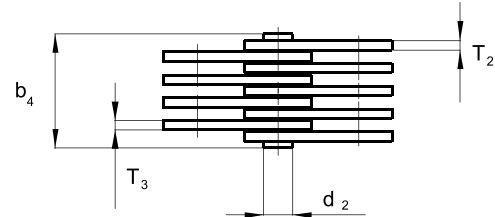
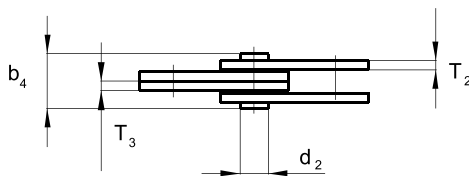

ACCESSORIES FOR LEAF CHAINS

End plates

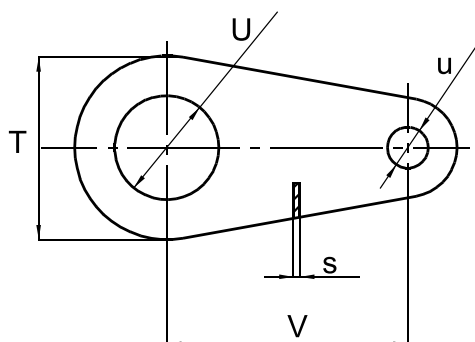

FOR CHAIN	HOLES DISTANCE	INNER PLATE WIDTH	HOLE DIAMETER	ATTACHMENT HOLE DIAMETER	PLATE THICKNESS
	V	T	U	u	s
	mm	mm	mm	mm	mm
AL 6	25,00	20,00	10,00	5,85	2,40
AL 6	25,00	20,00	10,00	6,05	2,40
AL 6	25,00	20,00	10,30	6,05	2,40
LH 08	19,91	18,00	9,30	5,12	2,00
LH 08	19,91	18,00	8,30	5,12	2,00
LL 08	15,00	16,00	6,30	4,55	1,50
LL 08	19,91	18,00	9,30	4,55	1,50
LL 08	20,00	18,00	9,30	4,37	1,50
LL 08	25,00	20,00	10,30	6,30	1,50
LL 10	20,00	18,00	8,30	5,13	1,60
LL 10	30,00	25,00	12,30	4,99	1,60
LL 10	30,00	25,00	12,30	5,13	1,60
LL 12	25,00	20,00	10,30	5,64	1,80
LL 12	25,00	20,00	10,30	5,82	1,80
LL 12	45,00	35,00	16,30	10,30	1,80
LL 16	40,00	36,00	22,00	8,40	3,00
LL 16	40,00	36,00	12,00	8,40	3,00
08 B STRONG	19,91	18,00	10,00	4,55	2,00

ACCESSORIES FOR LEAF CHAINS

Pins for cotter

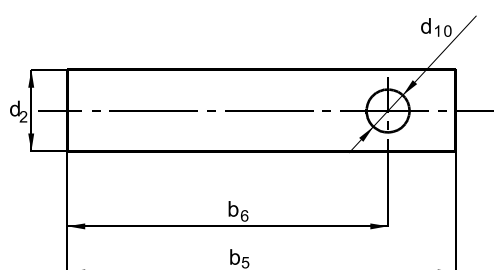

FOR CHAIN	PIN DIAMETER	PIN LENGHT	COTTER HOLE DISTANCE	COTTER HOLE DIAMETER
	d2 max.	b7 max.	b6	d10
	mm	mm	mm	mm
LL 1266	5,72	27,90	25,30	2,20
LL 1644	8,28	33,50	30,20	2,70
LL 1666	8,28	46,20	42,90	2,70
LL 1688	8,28	60,00	55,60	2,70

ACCESSORIES FOR LEAF CHAINS

Pins for cotter

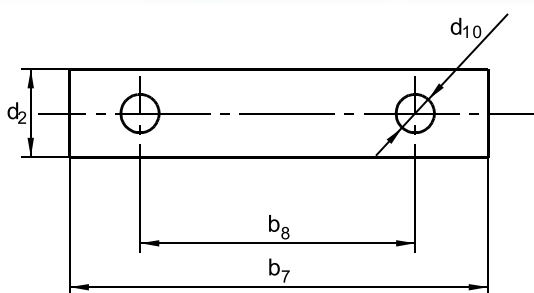

FOR CHAIN	PIN DIAMETER	PIN LENGHT	COTTER HOLE DISTANCE	COTTER HOLE DIAMETER
	d_2 max.	b_7 max.	b_8	d_{10}
	mm	mm	mm	mm
06 B 6x6	3,28	20,50	16,50	1,20
AL 534	5,08	24,10	18,00	1,80
AL 566	5,08	33,50	27,50	1,80
AL 622	5,94	19,30	12,30	2,20
AL 623	5,94	21,80	14,80	2,20
AL 634	5,94	26,30	19,80	2,20
AL 644	5,94	29,30	22,30	2,20
AL 666	5,94	39,50	32,50	2,20
AL 688	5,94	49,60	42,60	2,20
BL 434 = LH 0834	5,08	24,10	18,00	1,80
BL 522 = LH 1022	5,94	19,30	12,30	2,20
BL 523 = LH 1023	5,94	21,80	14,80	2,20
BL 534 = LH 1034	5,94	26,30	19,80	2,20
BL 544 = LH 1044	5,92	29,30	22,30	2,20
BL 546 = LH 1046	5,94	34,30	27,30	2,20
BL 566 = LH 1066	5,94	39,50	32,50	2,20
BL 588 = LH 1088	5,94	49,60	42,60	2,20
LL 0823	4,45	16,00	9,00	1,80
LL 0834	4,45	19,20	13,20	1,80
LL 0844	4,45	20,60	14,60	1,80
LL 0845	4,45	23,00	16,00	1,80
LL 0856	4,45	25,00	18,00	1,80
LL 0866	4,45	27,00	20,00	1,80
LL 1044	5,08	24,60	18,60	1,80

FOR CHAIN	PIN DIAMETER	PIN LENGHT	COTTER HOLE DIST.	COTTER HOLE DIA.
	d_2 max.	b_7 max.	b_8	d_{10}
	mm	mm	mm	mm
LL 1066	5,08	32,10	26,00	1,80
LL 1088	5,08	34,60	28,60	1,80
LL 1244	5,72	30,10	24,00	2,20
LL 1256	5,72	28,00	22,00	2,20
LL 1266	5,72	32,50	26,50	2,20
LL 1288	5,72	40,10	34,00	2,20
LL 12-12-12	5,72	54,10	48,00	2,20
LL 1634	8,28	32,60	24,50	2,70
LL 1644	8,28	36,20	28,00	2,70
LL 1646	8,28	42,40	34,40	2,70
LL 1656	8,28	44,60	36,50	2,70
LL 1666	8,28	48,80	40,60	2,70
LL 1676	8,28	55,10	44,00	2,70
LL 1688	8,28	61,80	53,30	2,70
LL 12xx	5,72	41,00	35,00	2,20
LL 16xx	8,28	77,40	70,00	2,70
AL 6xx	5,92	29,30	22,50	2,20
BL 5xx = LH 10xx	5,92	29,30	22,50	2,20
LL 16xx	8,28	66,00	59,50	2,70
LL 08xx	4,45	58,20	52,50	1,80
AL 6xx	5,94	38,00	33,00	2,20
BL 5xx = LH 10xx	5,94	38,00	33,00	2,20
AL 6xx	5,94	53,00	48,00	2,20
BL 5xx = LH 10xx	5,94	53,00	48,00	2,20
LL 16xx	8,28	55,00	47,00	2,70
AL 6xx	5,94	35,50	29,50	2,20
BL 5xx = LH 10xx	5,94	35,50	29,50	2,20
AL 8xx	7,92	44,50	36,50	2,70
BL 6xx = LH 12xx	7,92	44,50	36,50	2,70
LL 08xx	4,45	72,00	66,40	1,80
AL 6xx	5,94	31,40	26,40	2,20
BL 5xx = LH 10xx	5,94	31,40	26,40	2,20

ACCESSORIES FOR LEAF CHAINS

Holders

FOR CHAIN	WHOLE LENGTH	THREAD	THREAD LENGTH	HOLE DIAMETER	DIMENSION	DIMENSION	DIMENSION	DIMENSION	DIMENSION	DIMENSION	DIMENSION	DIMENSION
	L	M	Lz	u	A	B	C	D	E	F	F1	G
	mm		mm	mm	mm	mm	mm	mm	mm	mm	mm	mm
LL 0844	111,00	M 12	80,00	4,46	21,00	13,00	16,00	6,50	7,00	3,30	-	3,10
LL 1044 acc. to ČZ	172,00	M 14	140,00	5,13	28,00	17,00	17,00	7,00	12,00	1,70	3,40	1,70
LL 1044 acc. to DIN	172,00	M 14	140,00	5,13	28,00	17,00	17,00	7,00	12,00	3,40	-	3,40
LL 1066	172,00	M 14	140,00	5,13	25,00	24,00	24,00	7,00	12,00	3,40	-	3,40
LL 1266	171,50	M 16	130,00	5,82	27,50	28,00	24,20	7,50	8,50	3,80	-	3,80
LL 1644	300,00	M 16	260,00	8,40	32,00	25,00	25,00	12,70	12,00	6,50	-	6,50
LL 1656	165,00	M 20	100,00	8,40	55,00	25,00	33,00	12,70	12,00	3,15	-	3,15
LL 1666	155,00	M 20	90,00	8,40	32,00	25,00	40,00	12,70	12,00	6,50	-	6,50
LL 1666	100,00	M 20	45,00	8,40	32,00	25,00	40,00	12,70	12,00	6,50	-	6,50

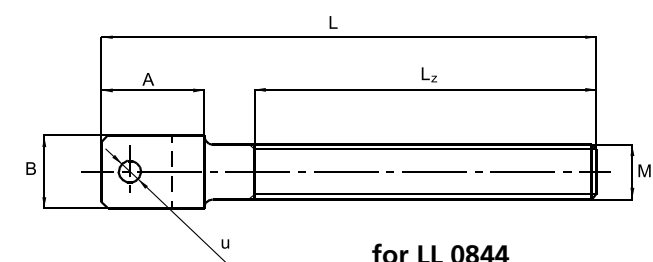

for LL 0844
LL 1044 to DIN
LL 1644

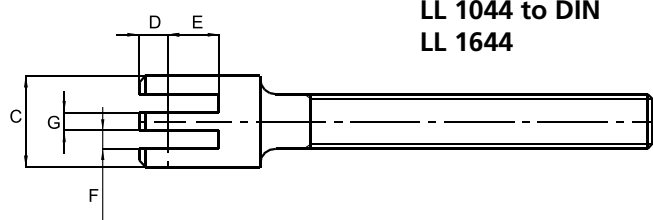

for LL 1066
LL 1266
LL 1666

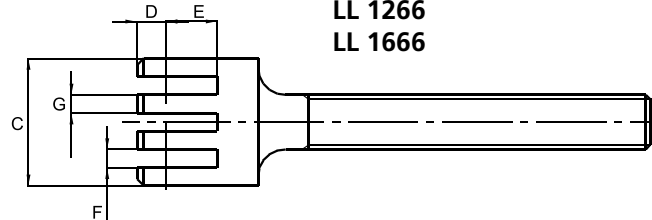

for LL 1656

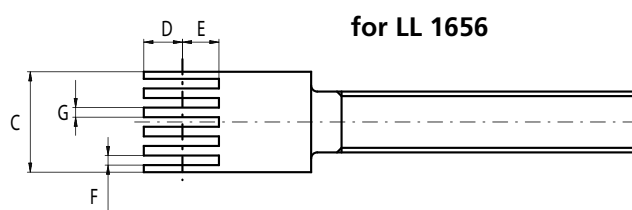

for LL 1044 ČZ standard

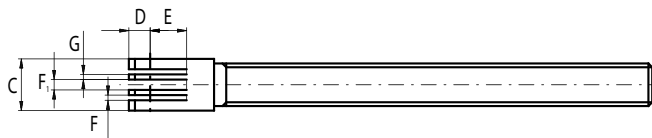



ACCESSORIES FOR LEAF CHAINS

Holders

FOR CHAIN	WHOLE LENGTH	THREAD	THREAD LENGTH	HOLE DIAMETER	DIMENSION	DIMENSION	DIMENSION	DIMENSION	DIMENSION	DIMENSION	DIMENSION
	L	M	L _z	u	A	B	C	D	E	F	G
	mm		mm	mm	mm	mm	mm	mm	mm	mm	mm
AL 644	134,00	M16	80,00	6,00	33,00	15,00	15,00	8,00	15,00	5,00	5,00

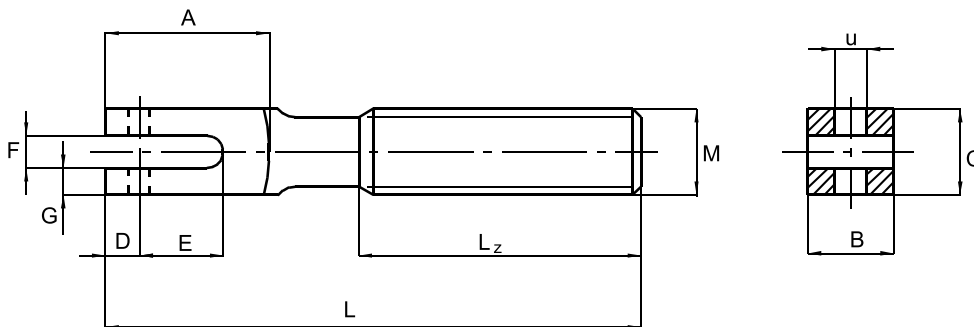

CALCULATIONS, TRANSMISSION DESIGN, MAINTENANCE

Calculation and design of transmissions	122–132
Chain lubrication	133–136
Chain assembly and disassembly	137–139
Methods of chain length alternations	140–141
Chain attendance and maintenance	141
Chain durability	142



ČZ Řetězy, Ltd. has summarised its long time experience in the field of chain transmissions into a comprehensive calculation and design of the chain transmission with the help of computers. Therefore, it can offer its customers help and service at solving of chain transmissions. That is why we recommend to contact our Design office that can help with designing, eventually suggests the most suitable solution of the required transmission. Please, remember that a well-designed transmission ensures trouble-free service and low maintenance cost with its long durability.

CALCULATION AND DESIGN OF CHAIN TRANSMISSIONS

Project and calculation of the chain transmission follows standards CSN 01 4809 and DIN 8195.

Chain selection and the first chain project are coming from Diagram 1 and 2, where the curves define each chain efficiency. They are valid only for the chain transmission where the driving wheel is with $z_1 = 19$ teeth and the driven wheel $z_2 = 57$ teeth. The next condition is axis distance $a = 40 p$ (100 p according to DIN standard), $\rho = 1$, $\varphi = 1$, $\mu = 1$, planned durability 10 000 (15 000 according to DIN standard) running hours and the allowed chain prolongation by the wear influence is 2 % (3% according to DIN standard) of the basic chain length.

The running conditions influencing the chain are various in practice, that's why it is necessary to make recalculation, to compare it with the ideal condition. We modify the value of transformed power P to the value:

$$P_D = \frac{P}{\mu\varphi\chi}$$

χ = coefficient of power from Table 1
 φ = coefficient of type

$\varphi = 1$ for the chains mentioned in Diagrams 1 and 2

$\varphi = 0,8$ for the chains not mentioned in Diagrams 1 and 2

$\varphi = 1,5$ for the long pitch chains according to standard CSN 02 3315 (DIN 8181)

μ = coefficient of the lubrication that you can find it in Table 2 (for details see chapter "Chain lubrication").

With this recalculated power and with the help of Diagrams 1 or 2 (depending on the chosen chain type) we determine the size of the chain.

Now we divide pre-projected axis distance with the chain pitch and with the help of Table 3 we select the next axis distance correction coefficient. With this coefficient we divide the power P_D and we get the corrigated power P_{1D} .

With the help of the P_{1D} we check or, if it is necessary, correct the selected chain in accordance with Diagrams 1 or 2.

Table 1 Power coefficient χ

Transmission ratio i	Shock coefficient $Y = 1$ Numbers of teeth z_1 of small wheel					Shock coefficient $Y = 2$ Numbers of teeth z_1 of small wheel					Shock coefficient $Y = 3$ Numbers of teeth z_1 of small wheel					Shock coefficient $Y = 4$ Numbers of teeth z_1 of small wheel				
	13	17	19	21	≥ 25	13	17	19	21	≥ 25	13	17	19	21	≥ 25	13	17	19	21	≥ 25
	1	0,39	0,73	0,83	0,93	1,11	0,28	0,53	0,60	0,67	0,81	0,24	0,42	0,52	0,58	0,70	0,21	0,34	0,43	0,53
2	0,50	0,82	0,93	1,04	1,26	0,36	0,60	0,68	0,76	0,92	0,30	0,50	0,59	0,66	0,80	0,26	0,44	0,52	0,61	0,73
3	0,57	0,88	1,00	1,12	1,36	0,42	0,65	0,73	0,82	0,99	0,35	0,55	0,63	0,71	0,86	0,29	0,51	0,58	0,65	0,79
5	0,64	0,96	1,09	1,22	1,49	0,47	0,71	0,80	0,89	1,09	0,40	0,61	0,69	0,77	0,94	0,33	0,57	0,63	0,71	0,86
≥ 7	0,67	1,02	1,15	1,30	1,59	0,49	0,75	0,85	0,95	1,16	0,42	0,64	0,73	0,82	1,00	0,35	0,59	0,67	0,75	0,92

Running conditions for the values in bars are not suggested.

If table 1 is used it is necessary to count with the index 1 for the small wheel, without regard if it is a driving or a driven wheel.

For the transmissions $i < 1$ is the value χ (λ) subtracted from the upset value $\frac{1}{i}$

Table 2 Lubrication coefficients μ

Power divides	Chain speed in ms^{-1}	Lubrication coefficients μ for			Lubrication types		
		perfect lubrication	insufficient lubrication without with dirt (m)	no lubrication	useful	acceptable	
I	up to 4	1	0,6	0,3	0,15	Light drip lubrication, 4 to 14 drops in 1 min.	Fat lubrication. Hand lubrication.
II	up to 7		0,3	0,15	not acceptable	Dipped lubrication by wetting in oil bath.	Drip lubrication, about 20 drops in 1 min.
III	up to 12		not acceptable			Force - feed lubrication	Oil bath with spattering disk.
	up to 12		not acceptable			Oil mist lubrication, force - feed lubrication with jet for small drip creation. Oil cooling if necessary, modificate!	Force - feed lubrication.

Table 3 Axis distance coefficients p

$a = 20 p$	$a = 40 p$	$a = 80 p$	$a = 160 p$
0,85	1,00	1,15	1,30

DIAGRAM 1

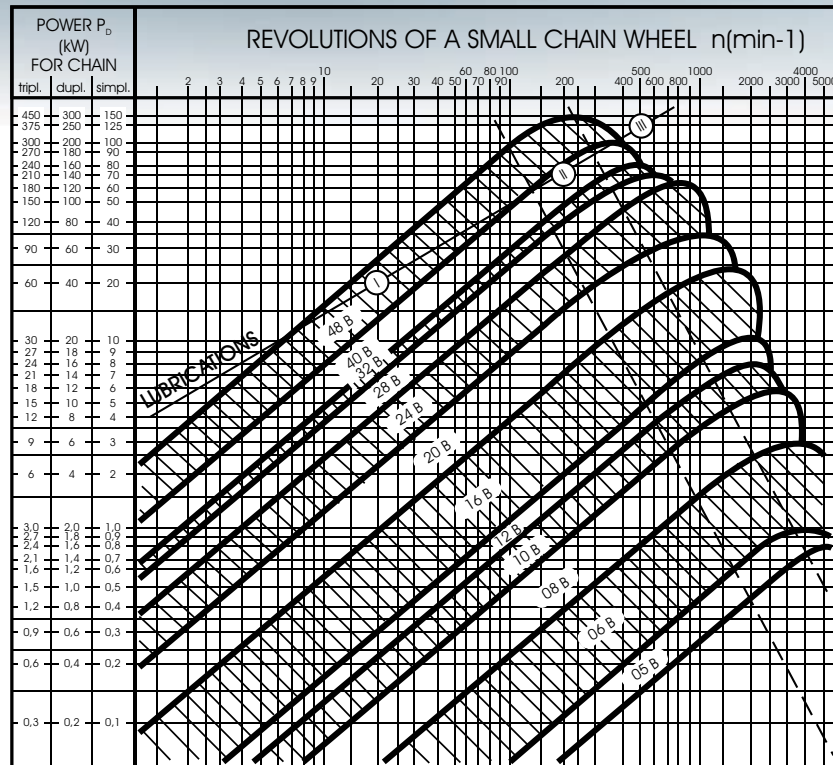
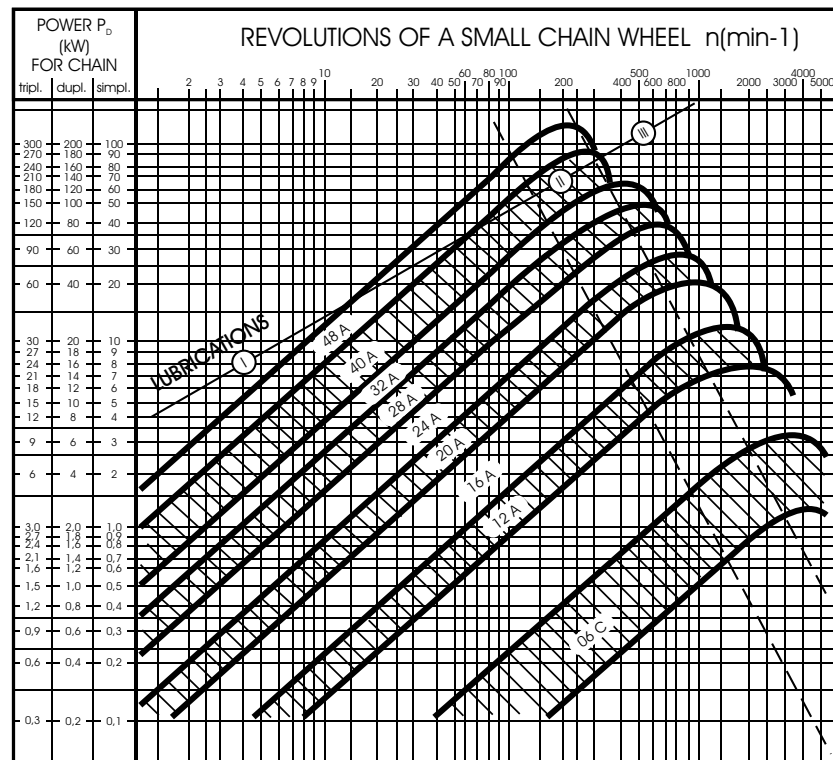

DIAGRAM 2



The values of the shock coefficient Y are selected according to the shocks, which are made by the run machine in the transmission.

- Y = 1 Shockless transmission
- Y = 2 Light shocks, middle intermediate load
- Y = 3 Middle shocks, abnormal intermediate load
- Y = 4 Heavy shocks, middle transformed shocks

Examples of the number values Y, shows Table 4.

Calculation check of a specified chain

For inspection of a selected chain, we made the calculation of a real ratios in the chain transmission and then compare them with allowed values. A new selection must be made, if the suggested chain does not correspond with these values.

Circumferential velocity of the chain $v = \frac{d \cdot n_1}{19100} \text{ [ms}^{-1}\text{]}$

where d is the diameter of the driven wheel spacing circle

$$d = \frac{p}{\sin \frac{180^\circ}{z_1}} \text{ [mm]}$$

n₁ = revolutions of the driving wheel [min⁻¹]

For comparison, allowed circumferential chain velocities are shown in Diagram 3.

Circumferential force from the transformed power on the chain wheel

$$F = \frac{P \cdot 1000}{v} \text{ [N]}$$

P = transformed power [kW]
v = circumferential velocity [ms⁻¹]

Diagram 3 Allowed circumferential chain velocities

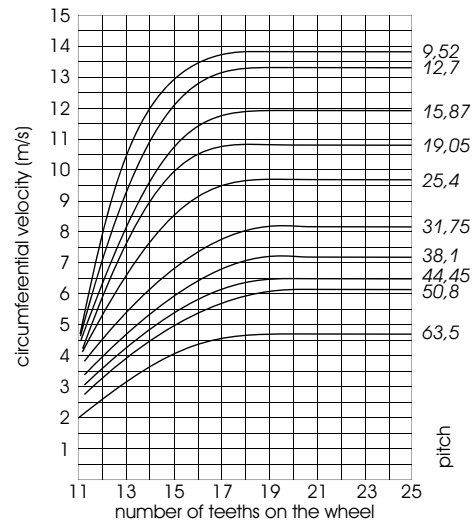

Circumferential force caused by the centrifugal force

$F_{oc} = q \cdot v^2$
q = weight of 1 m chain [kg m⁻¹] (see catalogue tables)

Total traction force

$$F_t = F_o + F_{oc} \text{ [N]}$$

Pressure calculation in the chain joint

$$p_p = \frac{F_t}{S} \text{ [MPa]}$$

S = chain joint surface
S = d₂ · b₂ [mm²] d₂ = pin diameter [mm] b₂ = outer width of the inner chain link (bush length) [mm], - see catalogue tables.

Direction pressure in the chain joint [p₁] is shown in Table 5 and it is necessary for the allowed pressure determination.

Allowed pressure in the chain joint

p_a = p₁ · λ [MPa]
λ = friction coefficient (see Table 6)

Table 6 Friction coefficient λ

Warning:
 $p_p < P_d$

Shock coefficient γ	Chains according to CSN	Friction coefficient λ																			
		$a = 20 p$					$a = 40 p$					$a = 80 p$					$a = 160 p$				
		i					i					i					i				
		1	2	3	5	7	1	2	3	5	7	1	2	3	5	7	1	2	3	5	7
1	02 3311, 02 3321	0,69	0,80	0,87	0,98	1,04	0,83	0,93	1,00	1,09	1,15	1,00	1,12	1,19	1,27	1,32	1,24	1,38	1,45	1,53	1,57
	02 3315	0,55	0,64	0,70	0,78	0,82	0,66	0,74	0,80	0,87	0,92	0,80	0,90	0,95	1,02	1,06	0,99	1,10	1,16	1,22	1,26
2	02 3311, 02 3321	0,50	0,58	0,64	0,72	0,76	0,60	0,68	0,73	0,79	0,84	0,73	0,82	0,87	0,93	0,97	0,91	1,01	1,06	1,12	1,15
	02 3315	0,40	0,46	0,51	0,58	0,61	0,48	0,55	0,58	0,63	0,67	0,58	0,66	0,70	0,75	0,78	0,73	0,81	0,85	0,90	0,92
3	02 3311, 02 3321	0,44	0,50	0,55	0,62	0,66	0,52	0,59	0,63	0,69	0,73	0,63	0,71	0,75	0,80	0,83	0,78	0,87	0,92	0,96	0,99
	02 3315	0,35	0,40	0,44	0,49	0,52	0,42	0,47	0,50	0,55	0,57	0,50	0,56	0,60	0,64	0,66	0,62	0,69	0,73	0,77	0,79
4	02 3311, 02 3321	0,40	0,46	0,51	0,57	0,61	0,48	0,54	0,58	0,63	0,67	0,58	0,65	0,69	0,74	0,77	0,72	0,80	0,84	0,89	0,91
	02 3315	0,32	0,37	0,40	0,45	0,48	0,38	0,43	0,45	0,50	0,53	0,46	0,52	0,55	0,59	0,61	0,58	0,64	0,67	0,71	0,73

Table 4 Number values γ

Shown values are the middle values at the axis distance $a = 40 p$. At the unfavourable conditions, it is necessary to count with additions.	Driving machines										
	Electrical engine	Combustion engines					Water turbines		Steam turbines	Piston steam machines	Driving transmissions (group drive)
		1 cylinder	2 cylinders	Up to 2 cylinders	4 cylinders and more	Fast	Slow				
								Low speed			
Lathes, drills	1,4										
Milling machines	1,5										
Planing machines	2,3										
Shaping machines	2										
Drawing machines	1,8										
Press machines	hydraulic	1,8			2,8	2,5	2,2				
	eccentric	2,5									
	lever	2									
Machines for wood grinding	1,8	4,5	4	3,7	3	2,5	2,5	3,5	3,5	1,8	
Weaving machines	2									2	
Sawing machines	revolving	1,5									
	drilled	2									
Spinning machines	1,5									1,5	
Piston compressors	single stage	2,5	5	4,5	4	3,5					
	duplex	2	4,5	4	3,5	3					
Centrifugal compressors	single stage	1,6	4	3,2	3	2,5	2				
	duplex	1,3	3	2,7	2,5	2	1,6				
Superchargers	1,5	3	2,7	2,5	2						
Ventilators	2,5	3,7								3,5 2,5	
Piston pumps	single cylinder	2	5	4	3,5	3	2,6	2,5	3,5		
	double cylinder	1,8	4	3,5	3	2,7	2,3	2,2	2,7		
Centrifugal pumps	1,5	3	2,8	2,5	2,2					2,5	
Rolling trains	transmitted	2,5									
	direct	3									
Crushing cylinders	2									2	
Ball mills	1,8									1,8	
Tube mills	2									2	
Hammer mills	2,5	5	4,5	4	3,5					2,5	
Calenders	transmitted	2,5									
	direct	3									
Cellulose grinders	1,8						3,2	3		3,5 1,8	
Shaking screens	2	4	3,5	3,2	2,8					4 2	
Peening rammers	2	5	4	3,5	3,2						
Rotating mixers	1,7	4	3,2	3	2,5	2					
Diggers	3			5	4,5	4				5	
Soil milling machines			5	4,5	4						
Mixers	1,6									1,6	
Bulk material transporters	1,5	3	2,8	2,5	2,2	2				2,8 1,5	
Piece material transporters	2	4	3,5	3	2,7	2			1		
Lifting machines	2,5	5	4	3,5	3	2,6				1,5	
Fork lift trucks	3			4,5	3,5					1,5	
Mining winches	2,5										
Generators	big equipment	1	2				1,2	1,5		1,8 1	
	small equipment	1,5	2,8				1,7	2,5		2 1,5	
Driven transmissions	1,5					2,3	2	2	2,5	2,5 1,5	

Table 5 Direction pressure in the chain joint p_1

Chain speed v [m/s]	Pressure in the chain joint p_1 in [$N\ cm^{-2}$] at the small wheel number of teeth															
	11	12	13	14	15	16	17	18	19	20	21	22	23	24	25	
0,1	3129	3129	3129	3139	3139	3149	3178	3198	3198	3208	3247	3247	3247	3247	3286	
0,2	2796	2923	3002	3012	3021	3021	3041	3041	3041	3071	3100	3119	3149	3169	3189	
0,4	2590	2708	2757	2825	2845	2865	2894	2914	2933	2943	2963	2972	2992	3021	3051	
0,6	2413	2511	2609	2678	2708	2737	2776	2786	2815	2835	2845	2865	2904	2943	2972	
0,8	2246	2384	2453	2531	2570	2619	2659	2678	2708	2727	2757	2776	2796	2835	2855	
1,0	2129	2266	2335	2413	2472	2541	2560	2590	2639	2668	2678	2708	2746	2766	2796	
1,5	1864	2001	2119	2207	2276	2335	2403	2433	2462	2492	2521	2551	2580	2600	2619	
2,0	1668	1805	1933	2029	2109	2178	2217	2276	2325	2364	2394	2423	2453	2482	2511	
2,5	1511	1658	1795	1893	1982	2050	2090	2148	2188	2227	2266	2305	2345	2347	2413	
3,0	1364	1521	1648	1756	1854	1942	2001	2050	2090	2129	2168	2207	2237	2276	2305	
4,0	1138	1305	1442	1560	1667	1746	1815	1873	1913	1962	2001	2040	2070	2109	2132	
5,0	932	1109	1275	1393	1491	1589	1668	1736	1785	1834	1877	1903	1942	1972	2011	
6,0		952	1108	1256	1364	1472	1550	1619	1658	1697	1746	1785	1725	1864	1893	
7,0			961	1099	1236	1354	1432	1501	1560	1599	1648	1687	1727	1766	1805	
8,0				981	1118	1226	1334	1403	1472	1521	1560	1609	1648	1687	1717	
10,0					912	1050	1148	1236	1305	1364	1403	1442	1491	1530	1560	
12,0						883	991	1099	1167	1236	1285	1334	1373	1403	1442	
15,0							785	912	999	1059	1118	1167	1216	1256	1295	
18,0								736	814	893	952	1010	1069	1118	1158	
21,0									667	755	814	883	942	991	1030	
24,0										500	588	667	730	804	863	912

Direction values according to Table 5 are valid for about 10.000 working hours at $Y = 1$, $\mu = 1$, $q = 1$, chain run over 2 wheels and the transmission ratio

$$i = \frac{n_1}{n_2} = \frac{z_2}{z_1} = 3.$$

Safety coefficient against breaking at statical load

$$k_s = \frac{F_b}{F_1} \geq 7$$

F_b = chain strenght in breaking [N] (see catalogue tables)

Safety coefficient against the breaking at dynamical load

$$K_d = \frac{F_b}{F_1 Y} \geq 5$$

Y = shocks coefficient (see Table 4)

If the suggested chain does not perform any of the mentioned values, it's necessary to choose the chain with bigger pitch, or with higher strenght.

Chain number of links calculation from chosen axis distance

$$x = 2 \cdot \frac{a}{p} + \frac{z_1 + z_2}{2} + \left(\frac{z_2 - z_1}{2\pi} \right)^2 \cdot \frac{p}{a}$$

According to the calculated chain number of links we choose the nearest even number of links. Exceptionally we choose the odd number of links, because it's necessary to use the reducing link, which decreases the chain strenght. We recalculate the axis distance for the chosen number of links.

Axis distance calculation

$$a = \frac{p}{8} \left[2x - z_1 - z_2 + \sqrt{(2x - z_1 - z_2)^2 - F (z_2 - z_1)^2} \right]$$

we find the coefficient F in Table 7

Table 7 Coefficient F

$\frac{X - z_1}{z_2 - z_1}$	F	$\frac{X - z_1}{z_2 - z_1}$	F	$\frac{X - z_1}{z_2 - z_1}$	F	$\frac{X - z_1}{z_2 - z_1}$	F
12,00	0,8106	2,90	0,8116	1,37	0,8215	1,19	0,8310
11,00	0,8106	2,80	0,8118	1,36	0,8219	1,18	0,8318
10,00	0,8107	2,70	0,8119	1,35	0,8222	1,17	0,8326
9,00	0,8107	2,60	0,8121	1,34	0,8226	1,16	0,8336
8,00	0,8107	2,50	0,8123	1,33	0,8230	1,15	0,8346
7,00	0,8108	2,40	0,8125	1,32	0,8234	1,14	0,8358
6,00	0,8108	2,30	0,8127	1,31	0,8238	1,13	0,8372
5,00	0,8109	2,20	0,8130	1,30	0,8243	1,12	0,8387
4,80	0,8109	2,10	0,8134	1,29	0,8248	1,11	0,8405
4,60	0,8109	2,00	0,8138	1,28	0,8253	1,10	0,8425
4,40	0,8110	1,90	0,8143	1,27	0,8258	1,09	0,8448
4,20	0,8110	1,80	0,8150	1,26	0,8264	1,08	0,8474
4,00	0,8110	1,70	0,8158	1,25	0,8270	1,07	0,8503
3,80	0,8111	1,60	0,8170	1,24	0,8276	1,06	0,8537
3,60	0,8112	1,50	0,8185	1,23	0,8282	1,058	0,8544
3,40	0,8113	1,40	0,8207	1,22	0,8289	1,056	0,8551
3,20	0,8114	1,39	0,8209	1,21	0,8295	1,054	0,8559
3,00	0,8115	1,38	0,8212	1,20	0,8302	1,052	0,8567

Chain wheel dimension calculation for roller and bush chains

We subtract the chain wheel dimensions according to the relations shown in Tables 8 and 9.

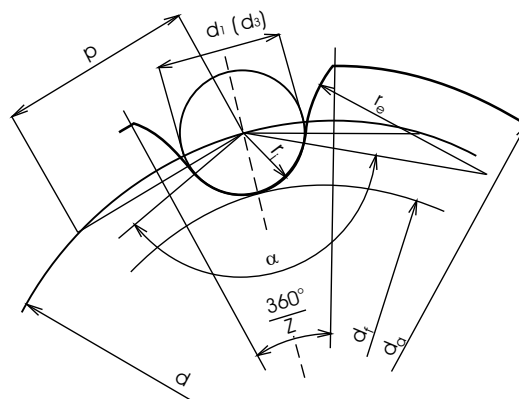

Table 8

PARAMETERS	Zn	FORMULA FOR CALCULATION
Pitch circle diameter	d	$d = \frac{p}{\sin \frac{180^\circ}{z}}$
Root circle diameter	d_f	$d_f = d - 2r_i$
For the gap with smallest width 1. bottom tooth gap radius 2. tooth face radius 3. opening angle	$r_{i \min}$ $r_{e \min}$ α_{\max}	$r_{i \min} = 0,505 \cdot d_1 (d_3)$ $r_{e \min} = 0,12 \cdot d_1 (d_3) \cdot (z+2)$ $\alpha_{\max} = 140^\circ - \frac{90^\circ}{z}$
For the gap with biggest width 1. bottom tooth gap radius 2. tooth face radius 3. opening angle	$r_{i \max}$ $r_{e \max}$ α_{\min}	$r_{i \max} = 0,505 \cdot d_1 (d_3) + 0,069 \sqrt[3]{d_1 (d_3)}$ $r_{e \max} = 0,008 \cdot d_1 (d_3) \cdot (z^2+180)$ $\alpha_{\min} = 120^\circ - \frac{90^\circ}{z}$
roller diameter	d_1	
bush diameter	d_3	
addendum circle diameter	d_a	$d_{a \min} = d + 0,5 \cdot d_1 (d_3)$ $d_{a \max} = d + 1,25 p - d_1 (d_3)$

Dimensions d_3 are valid only for bush chains.

Basic dimension calculation of the rims cross cut at simple, duplex, triplex chain wheels, must be made according to Table 9.

Table 9

PARAMETER TITLE	Zn	FORMULA FOR CALCULATION		
biggest rim diameter	d_g	$d_g = d - 2f$		
pitch circle and rim radius difference	f	$f = 0,7p$ for standard chains $f = 0,4p$ for long pitch chains		
distance between the rows at multiple row chain	p_t	according to datas in catalogue tables		
tooth round radius	r_x	$r_x = 1,5 d_1$		
tooth round value	b_a	$b_a = (0,1 \div 0,15) d_1$		
chain inner width	b_1	according to datas in catalogue tables		
chain wheel tooth width	b_{r1}	chain pitch		
		$p \leq 12,7$	$p > 12,7$	
		simplex	0,93 b_1	0,95 b_1
		duplex	0,91 b_1	0,93 b_1
triplex	0,88 b_1	0,93 b_1		
chain wheel rim width	duplex	b_{r2}	0,91 $b_1 + p_t$	0,93 $b_1 + p_t$
	triplex	b_{r3}	0,91 $b_1 + p_t$	0,93 $b_1 + p_t$

CHAIN WHEELS :

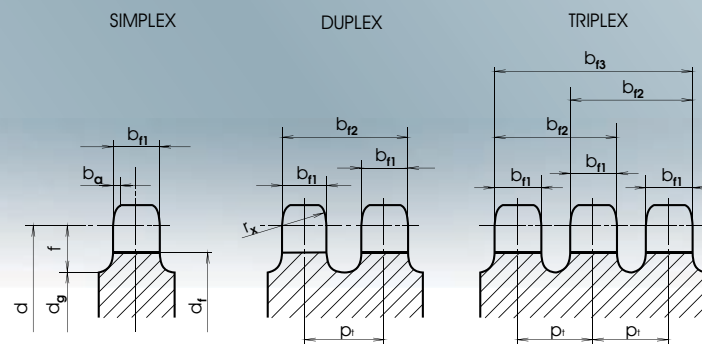

Tables 8 and 9 construction supplement :

1. Evolvent shape (radius r_e) of the tooth head is allowed. You must keep the standard values, which are in Tables 8 and 9.
2. Recommended maximum tooth surface roughness is $Ra = 3,2 - 6,3$
Modification A in extent to $Ra = 3,2$.
Modification B in extent to $Ra = 6,3$.
3. Allowed maximum radial run-out of the root circle is $0,0007 d_i + 0,076$ mm, but the top is 0,76 mm. Maximum side run-out of the root circle can be $0,0009 d_i + 0,076$ mm, but the top is 1,14 mm.
These methods are valid for the general transmission usage, for which special requirements are not suggested. In special cases it is necessary to choose smaller deviations, respect to the chain transmission run exactness, for example car timing gears.
4. A special standard is valid for the mentioned calculation formulas and suggestions, which are not valid for multiple gear freewheels of bicycles.
5. Limited deviations of the chain wheel tooth width b_{11} at single row, b_{12} at duplex and h_{14} at triplex are chosen, dimension b_{13} is informative.

Standard CSN 260491 indicates dimensions of the chain wheels for long pitch chains.

CZ Retezy, Ltd. resumes its long time experience in the field of chain transmission into a complex calculation and suggestion of the chain transmission with computer help. Hereby, we offer our customers service and help with the chain transmission solution.

We recommend our customers to contact Design office of CZ Retezy, Ltd., which can help with the suggestion or suggest the optimal solution for the required transmission. Please, remember that a well suggested transmission insures long durability, no failure and low maintenance costs of the chain transmissions.

Chain wheel materials

Materials used for the chain wheels vary according to the transmission type and to the number of teeth of the chain wheel.

For the pinions, it is better to use cemented steels for example 12020, 14220, because the chain wheel heat treated teeth are very hard and resist against the wear. These materials are mostly used, because at small number of teeth of the chain wheel, the tooth touches the chain frequently, and is worn-out. Steel without treatment, for example 11600, is possible to use for wheels with bigger number of teeth, because the tooth is not so frequently in touch with the chain and transformed force is resolved to more teeth. Big chain wheels (for chains with pitch 19,05 mm and more) are produced from cast iron with hardness about $HB = 220$, or from steels for castings. Chain wheels produced from plastic, zinc alloy etc. transforming low forces can be used for different transmissions (type writers, printing machines, toys etc.).

Rules for a well-functioning chain transmission

If you follow the below mentioned rules, you will be satisfied with the long durability of the chain transmission. Any deviation from these rules could cause a sudden damage of the chain and its lower durability.

Rules:

- To avoid the transmission oscillation, dimension the shafts and bearings sufficiently.
- Chain wheels must be mounted in the line and shaft axis must be parallel. Mounting mistakes are shown in Layouts 2 and 3. At a wrong mounted transmission, the chain is stressed not only by the traction force, but also by the bending force, which decreases the chain durability. It can cause the break of the chain. The chain plates with the side force effect, touch the chain wheel sides and cause excessive wear.
- It is suggested to locate the chain wheel as near as possible to the bearings, in order to decrease the pressure in them and also to decrease the chain wheels oscillation because of production incorrectness.
- At a small chain wheel keep the minimum number of teeth $z_1 = 17$, because the big angle at wheels with a low number of teeth over which the chain joint must turn have a big influence on excessive wear.

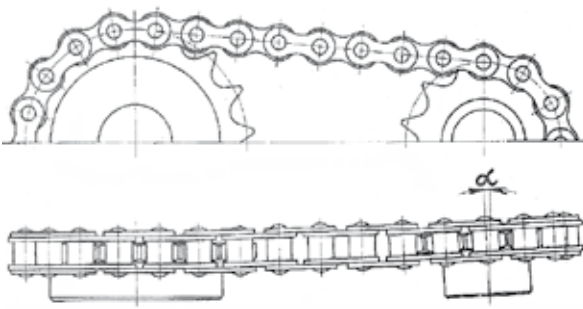

Layout 2 Chain wheels axis parallelism defect

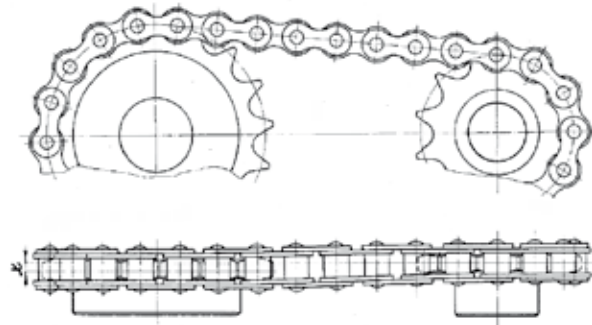

Layout 3 Chain wheels offset

- At a big chain wheel it is recommended not to exceed the number of teeth $z_2 = 120$ at standard transmissions.
- Examples in Layouts 4, 5, 6 show how it is possible to arrange the chain transmission. For improvement of the chain kinematics, it is better to locate the tensile branch up. If a stretching roller is used in the chain transmission, it is necessary to use such a stretching roller that has odd number of teeth, or a stretching roller which is smooth. It is better to choose a firm stretching roller with adjusting, then with a spring, because that causes additional force into the chain.
- Use a small chain wheel with odd number of teeth (if the construction allows) for reaching a chain steady wear.
- 100 multiple of the chain pitch is the maximum allowed axis distance for standard transmissions.
- For levelling the initial prolongation of the chain and for stress decreasing of the worn chain, it is necessary to constructionally ensure the axis adjusting of one of the shafts. If it is not possible to follow these conditions, it is necessary to inbuild a stretching roller into the transmission.

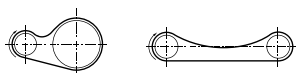

Layout 4 Incorrectly solved transmissions

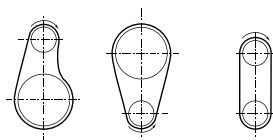

Layout 5 Preferably solved transmissions

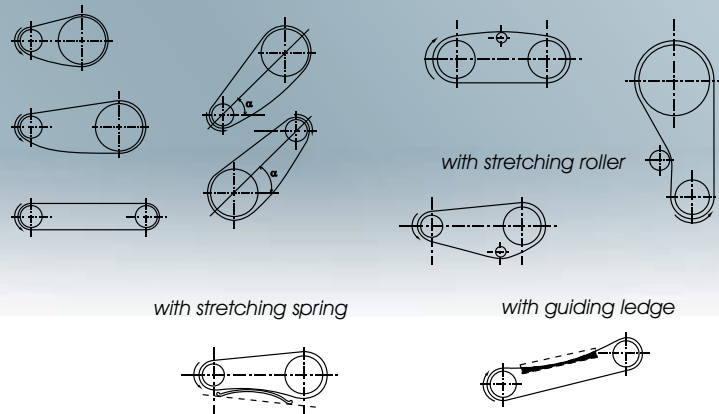

Layout 6 Correctly solved transmissions

Chain transmission solutions

Chain transmissions, as mentioned before, have many advantages against other transmissions (belt, gearwheels and others), that is why it also allows to solve complicated transmission systems with a lot of chain wheels. But like at every transmission it is necessary to follow some specific instructions for a good function and durability. The instruction, how to preferably solve the chain transmissions including the stretching elements and guiding lathes shows Layout 1.

Layout 1 Chain transmission arrangement examples

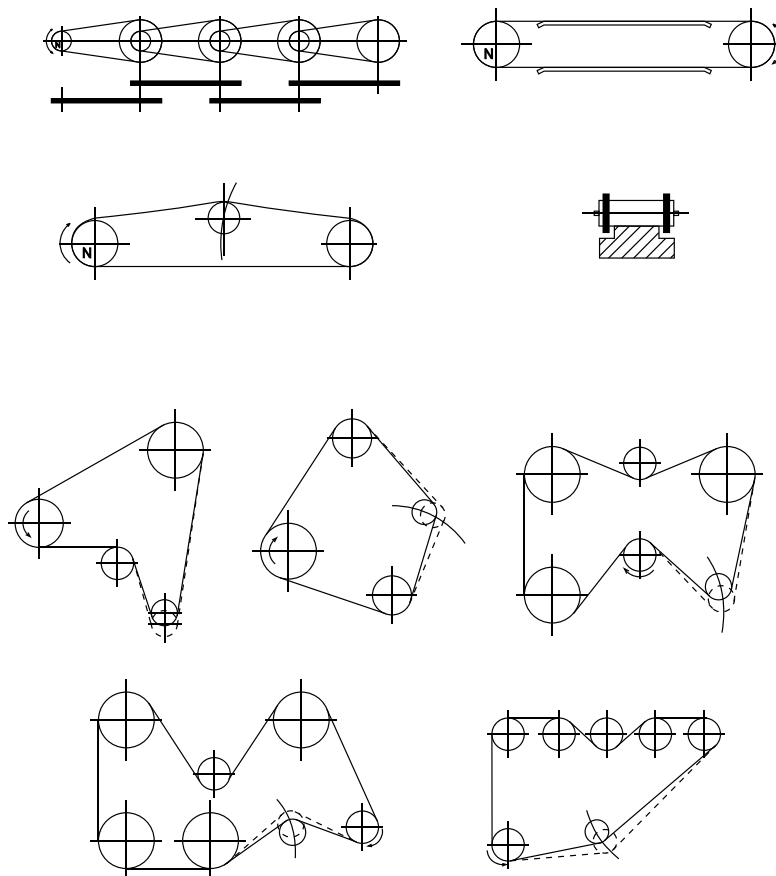

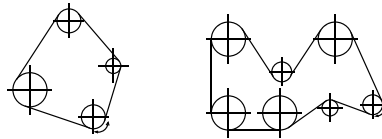
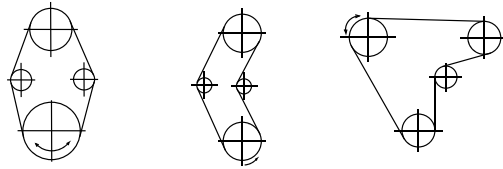
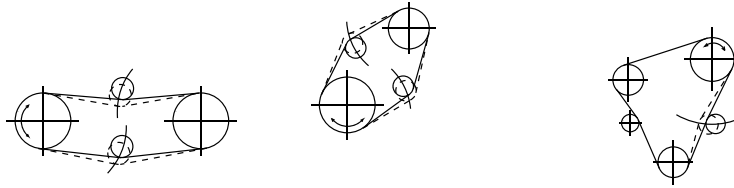
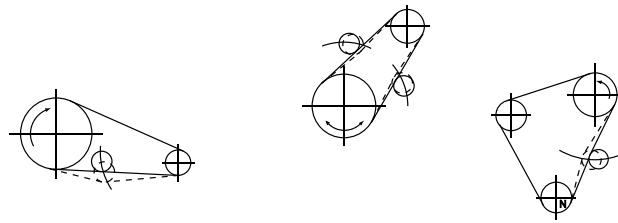
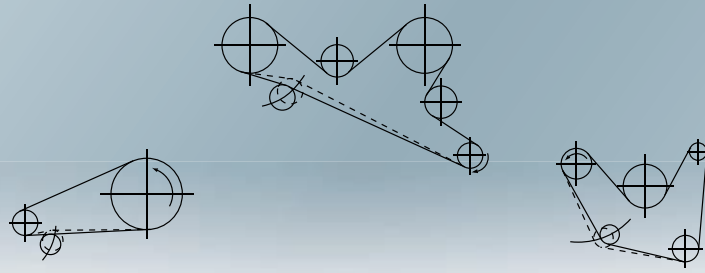

Drive of multiple shafts with stretching wheels

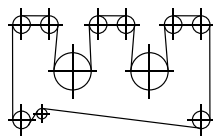

Drive of a roller track

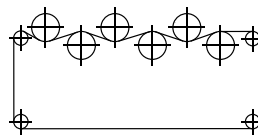

Drive of a light rolling mill

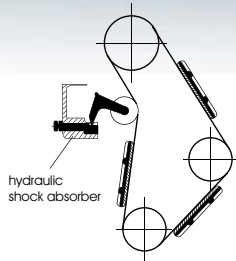
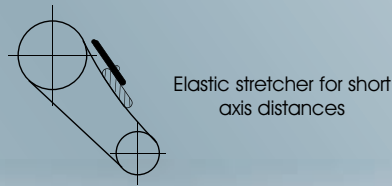

Driving gear with guiding lathes and a stretching wheel with a shock absorber

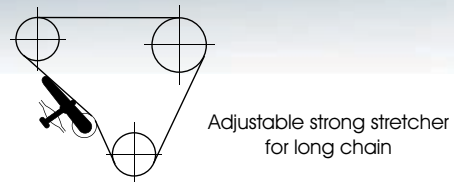

CHAIN LUBRICATION

Every chain in ČZ Řetězy, Ltd. is lubricated and conserved in the last operation, but during the next usage periodic lubrication is necessary. Insufficient lubrication often causes excessive elongation or failure.

The lubrication type is already determined at the chain transmission project, and by this are also determined the lubricating intervals. Three types of lubrication are determined by standard CSN 014809 and by Diagrams 1 and 2. Recommended lubrication according to Diagrams 1 and 2 are the minimal conditions. It is recommended to use the closest efficient lubricating process according to your possibilities.

It is also efficient to follow the instructions of machine and transmission producers, and technical advances from ČZ Řetězy, Ltd.

Efficiency of different lubrication types is described in Diagram 4.

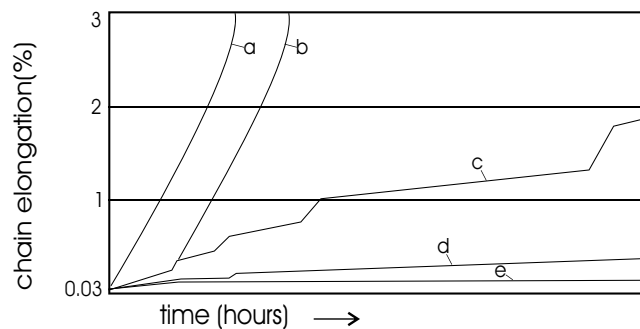

Diagram 4 Lubrication influence on the elongation

- Curve a** indicates the chain running without lubricating (dry conditions). These conditions lead to a strong joint wear, where corrosion elements owing to friction appears and slip surfaces are seizing. This can lead to a hard joint (seize) and in extreme cases even to chain breakage.
- Curve b** indicates the influence of lubricant efficiency, which is applied on the chain by producer. The wear process is slowing down, until the lubricating qualities of the lubricant coating are decreased. After this time, if the chain is not lubricated again, it works without lubrication (dry conditions). Then the wear course is the same as at curve a.
- Curve c** describes the wear ratio at irregular lubrication, when the chain works for some time without lubricant between lubricating intervals. Steep parts of the curve show the work without lubricant.
- Curve d** shows the effect of unsuitable bad-quality dirty lubricant, or its absence to the chain wear. In this case the uneven wear in the joints appears.
- Curve e** describes the optimal lubrication. The slip surfaces in the joints are uniformly polished, the wear is not almost not measurable. The lubricant is not contaminated by products from the wear. There is a minimum chain elongation according to the chain wear.

Manual lubrication

Apply the lubricant by the oil can or brush it between the plates of inner and outer link on the inner side of the chain free section according to Layout 7. Clean the chain before lubricating, if it is dirty. Spray lubricant is possible to use for manual lubrication. It is especially suitable for secondary transmissions treatment of motorcycles and bicycles. Use the liquid and spray lubricants with sufficient penetration efficiency to ensure the lubricant penetration into the chain joint.

Warning :

Lubricate the chain only when the device is shut down.

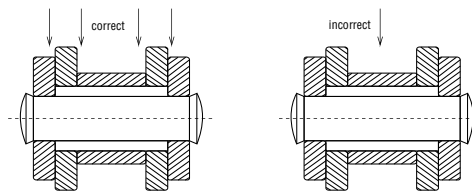

Layout 7 Manual lubrication

If you want to increase the lubricating interval, lubricate the chain by grease which is determined for chains. The best method is insertion of the cleaned chain into a hot grease (about 80 °C).

Before insertion into the grease fasten the chain on a string or wire for better manipulation. Warm up the grease slowly in a water bath, (see Layout 8) to prevent the grease overheating and loosing the lubricating qualities. Leave the chain in the bath until it reaches the bath temperature, then move the chain in order to get the grease into the chain joints. No air bubbles should not leak from a well lubricated chain. Take the lubricated chain out of the bath, let it drip and cool down when hanging.

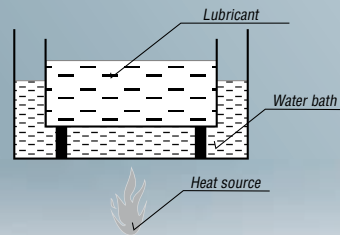

Layout 8 Water bath for warming up of grease

Drip lubrication

The drip lubrication is usually performed by drip lubricators or by a dosing device. Oil drops should fall between inner and outer plates. Necessary oil amount depend on the chain speed and it should be approximately 4 - 10 drops in a minute. At this dropping interval, the consumption is about 0,8 l in 24 hours. This brings a relatively high consumption of the lubricant. Beside this, some oil can disgorgel and pollute the cover and the machine. That is why you should equip the cover with a catcher of the excessive oil. It is necessary to check the function of the drip lubricator or the dosing device. This lubrication method is not too much environment-friendly.

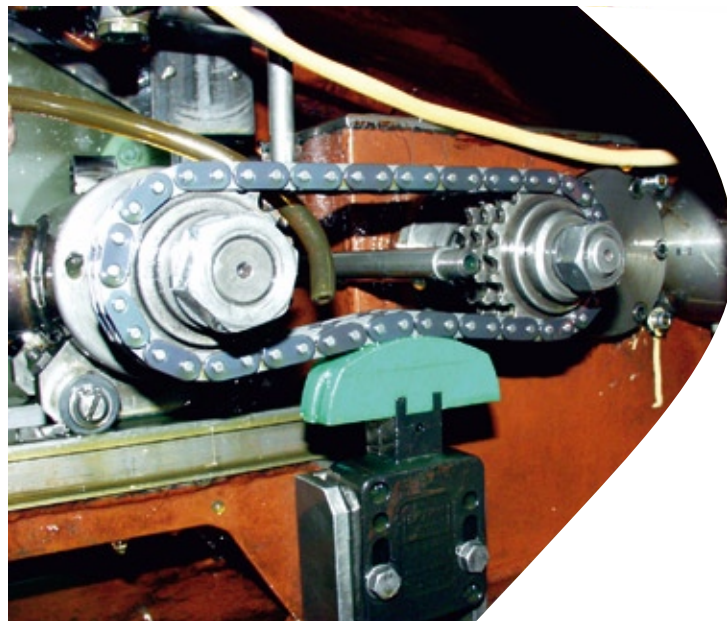

Layout 9 Dripping equipment

Bath or disc lubrication

The chains working in closed sealed covers (transmission boxes) can be lubricated by wadening in oil bath (see Layout 10). To avoid the oil over-heating, loosing its qualities, decreasing the transmission efficiency, the chain should be dipped only to one half of its height. For improving the lubrication efficiency we recommend to use a splashing disc, which is mounted on the shaft and dipped in the oil so that the centrifugal force could splash the oil on other parts of the chain.

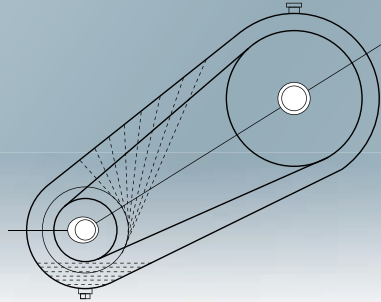

Layout 10 Bath or disc lubrication

Force-feed lubrication

The force-feed lubrication is the most efficient type of lubrication. Uniform stream of the oil created by a pump is coated on the whole width of the free inner section of the chain in its direction of movement.

The oil quantity must be adjusted so that the oil from the chain should partially run down before it gets in contact with the chain wheel. Too big layer of oil carried by the chain will cause in contact with the chain wheel unnecessary oil overheating and decreasing of the transmission efficiency.

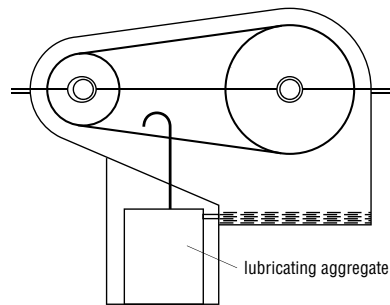

Layout 11 Force - feed lubrication

Oil viscosity recommendations are mentioned in the following table

Ambient temperature	-5 °C up to 25 °C	25 °C up to 45 °C	45 °C up to 65 °C
Viscosity class	SAE 30	SAE 40	SAE 50

CHAIN ASSEMBLY AND DISASSEMBLY

Assembly

Most of the transmissions are designed so that we could set the chain on the chain wheel teeth and then it is connected with a connecting link.

Chains with smaller pitches are connected by laying the ends of the chain on one of the wheels with the help of teeth spaces, which sets the distance corresponding with the pitch of the connecting link - see Layout 10.



Layout 10. Chain connecting on the chain wheel

Warning :

When using the connecting link with a flexible safety pin, it is necessary to assemble the closed part of the safety pin in the direction of chain movement - see Layout 11.

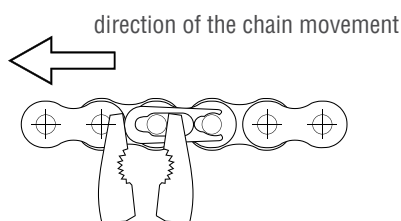

Layout 11. Correct assembling of the connecting link

At long pitch chains, which are heavier, a special puller is used which draws the free ends of the chain together, in order to put on the connecting link easily - see Layout 12.

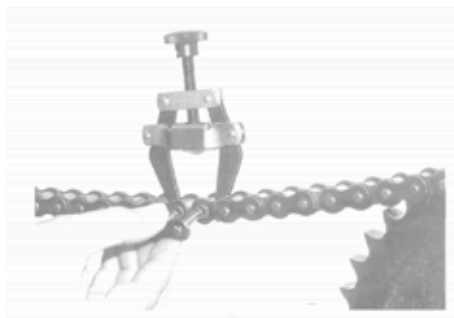

Layout 12. Setting the ends of the chain by a puller

At some transmission types is from different reasons required that the chain must be connected as endless, it means to be without a disassembling connecting link. A riveting (outer) link is used for connecting in these chains. The chain connection is mostly made out of the transmission and then the connected chain is mounted on the chain wheels, which must be modified for this type of connection (for example wheel sliding on the shaft). Special tools must be used for this type of assembly.

Disassembly

If the chains are connected by removable connecting links, the disassembly is easy and proceeds in a reverse sequence than by the assembly of the chain, which was described in the chapter before. Chains connected as endless ones which have to be disassembled directly on the chain transmission must be disassembled by special tools. These make disassembling easier and do not damage the transmission. Disposed is only the outer link, by which is the chain disassembled, this one cannot be used anymore. Each disassembly of the endless chain is destructive.

Chain disassembly out of the equipment

If we disassembly the chain out of the transmission, it is better to grind the unriveted pin heads, and then by the tool as shows Layout 13, knock out the pins from outer plate with the help of a mandrel and a hammer.

All types of assembling and disassembling tools are available in CZ Retezy s.r.o., or at our distributors.



Layout13. Chain disassembly with the help of a mandrel and a hammer.

Tooling for hand disassembling of the chain

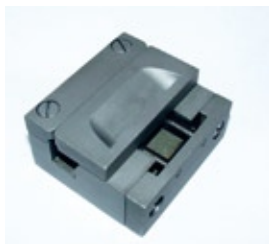

TYPE DP 1



TYPE DP 2

TYPE	using range
DP 1	pitch 9,525 - 19,05
DP 2	pitch 25,4

TYPE	using range
VZR 1	F 100, F 200, F 300, 082
VZR 2	pitch 9,525 - 15,875
VZR 3	pitch 25,4

Tooling for chain disassembling



TYPE VZR 1



TYPE VZR 2



TYPE VZR 3



Tooling for reparations of the chain with pitch 7,774 - 31,8 mm



TYPE DO

Tooling for pin riveting



CHAIN TYPE	TOOLING CODE
219	6,48,275,000
05 B-1,2	6,48,206,000
06 B-1,2,3	6,48,183,000
06 C-1,2,3	
062 C	6,48,162,000
1/2"x3/16" MOFA	
1/2"x3/16" V.D.	
1/2"x1/4" MOFA	
O86	
08 B-1,2,3	
O81	6,48,175,000
O82	
1/2"x3/16" VELO	
08 A-1,2,3	6,48,255,000
10 B-1,2,3	6,48,200,000
10 A-1,2,3	
12 B-1,2,3	6,48,191,000
12 A-1,2,3	6,48,192,000
12 B ZP	
16 B-1,2,3	6,48,277,000
16 A-1,2,3	

Tooling for roller punching

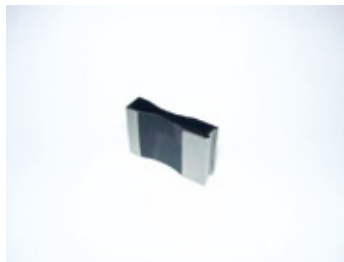

CHAIN TYPE	TOOLING CODE
219	6,48,276,000
05 B-1,2	6,48,242,000
06 B-1,2,3	6,48,142,000
062 C	
1/2"x3/16" V.D.	
1/2"x3/16" MOFA	
1/2"x1/4" MOFA	
06 C-1,2,3	6,48,184,000
O81	6,48,158,000
O82	
1/2"x3/16" VELO	
08 A-1,2,3	6,48,256,000
O86	6,48,141,000
08 B-1,2,3	
10 B-1,2,3	
10 A-1,2,3	
12 B-1,2,3	6,48,143,000
12 B ZP	
12 A-1,2,3	
16 B-1,2,3	6,48,278,000
16 A-1,2,3	6,48,311,000

Tooling for pin punching-out



CHAIN TYPE	TOOLING CODE
219	6,29,620,000
O6 B-1	6,29,346,000
O6 C-1	
O5 B	
O6 B-2	6,29,347,000
O62 C	
O6 C-2	
O6 B-3	6,29,348,000
O6 C-3	
O81	6,29,040,004
O82	
1/2"x3/16" VELO	
1/2"x3/16" MOFA	6,29,563,000
1/2"x3/16" V.D.	
O8 A-1	
O86	6,29,349,000
O8 B-1	
10 B-1	
10 A-1	
1/2"x1/4" MOFA	
08 B-2	6,29,350,000
10 B-2	
10 A-2	
08 B-3	6,29,351,000
10 B-3	
10 A-3	
12 B-1	6,29,353,000
12 A-1	
12 B ZP	
12 B-2	6,29,354,000
12 A-2	
12 B-3	6,29,355,000
12 A-3	
16 B-1	6,29,622,000
16 A-1	
16 B-2	
16 A-2	
16 B-3	6,29,646,000
16 A-3	

METHODS OF CHAIN LENGTH ALTERNATIONS

Chain transmission is favourable against other current transmissions (belt, gearwheels), because it is possible to change the axis distance easily by changing the chain length and shifting one of the wheels. Mainly it is preferable to use the chains with even number of links, in order to prevent mounting of the reducing link which decreases the static strength about 30 % . At less difficult transmissions is also possible to shorten the chain, in operating wear reason, where is not possible to shift the chain wheels and where a big chain deflection can make problems in running.

Methods of chain elongation

1. Chain elongation from even number of links to even number of links :

- We disassembly the chain in the connecting link position, or at any other position if the chain is connected as endless.
- After disassembly we insert the required number of links decreased about one into the chain.

Example : I require elongation about four links, I insert $4 - 1 = 3$ links into the chain, i.e. two inner and one outer link.

- We perform the chain reconnection as follows :
 - a) two connecting links with a flexible safety pin
 - b) two outer links
 - c) one outer link and one connecting link with a flexible safety pin

2. elongation of the chain with even number of links to odd number of links :

- We disassembly the chain as in point 1.
- After disassembling we insert an offset link into the chain, or a double offset link. If we require longer elongation, we must also insert the required number of links.
- If we use the offset link, we decrease the number of inserted links about one.
- When the double offset link is used we decrease the number of inserted links about two.
- Chain reconnection is made as follows :
 - a) offset link in connection with connecting link with flexible safety pin, or with outer link,
 - b) offset double link between connecting links with flexible safety pin,
 - c) offset double link between two outer links,
 - d) offset double link between one connecting link with flexible safety pin and with one outer link.

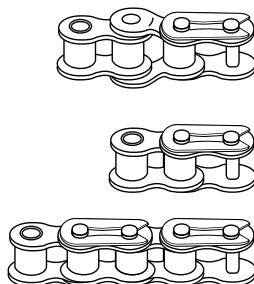

Layout 35. Illustration of the chain elongation types

Methods of chain shortening

Chain shortening is performed by the same method like elongation. We must disassembly the chain in two positions, in order to remove the excessive number of links.

CHAIN ATTENDANCE AND MAINTENANCE

Chain failures, especially their fast wear, can only seldom be charged to the construction mistakes, or to mistakes in chain dimensioning. The reason is often incorrect lubrication and maintenance. Durability and effectiveness of transmitted output depend on correct treatment of the chain transmission. Beside the correct mounting of the chain wheels, chain lubrication is very important, especially its plane lubricity (it is between the pin and the bush). The chain is created from many bearings (joints), where a small wear of one joint, invokes a big wear at the total sum. Therefore, it is necessary to pay attention to lubrication and treatment of these small chain bearings like to bearings in engineering.

It is necessary to respect the following chain transmission maintenance instructions:

- Lubricate the chain transmission in regular intervals or permanently (according to usage) see chapter - "Chain Lubrication".
- Ensure failure-free function of the lubricating equipment.
- Treat the chain by sufficient lubricant for the selected type of transmission and conditions under which it works.
- Check the wear conditions of the chain and the chain wheel.
- Connecting links and attachments of the chain are subject to increased wear, check them regularly and replace them if necessary.
- An open chain transmission must be provided with a suitable cover to prevent the dirt from getting into the chain.
- Never mount a new chain on extremely worn wheels.
- In case of longer season pauses treat the chain in order to prevent it against corrosion.
- Mount the chain to the wheels in the same position like before disassembly.
- Fix the deflection of the chain free section regularly.
- Check the guiding lathes of the chain regularly if there are any in the transmission. Replace the worn lathes immediately.

Warning :

Big or too small deflection of the chain free section is decreasing its durability, therefore it can cause a chain failure (bearing stress, chain fall from the chain wheel, jerking motion, etc...).

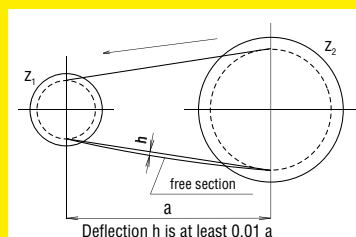

CHAIN DURABILITY

Because the chain is a mechanical part assembled from many parts, it has its own technical durability. Chain durability is determined by the allowed operation elongation. The value of elongation is given by the standard and it is determined so that the chain transmission could ensure the quality force transfer, sufficient for safety operating. Chain elongation ΔL is expressed by the length difference of the worn out chain L and basic chain length L_z

$$\Delta L = L - L_z$$

Chain basic length L_z is calculated : $L_z = x \cdot p$

x = number of links

p = chain pitch

Value of the allowed elongation ΔL_{max} is not the same at all chains :

- a) roller and bush chains for general use $\Delta L_{max} = 2\% L_z$ according to CSN, $\Delta L_{max} = 3\% L_z$ according to DIN
- b) high speed chains are mostly used in car industry (timing, balancing...) $\Delta L_{max} = 1\% L_z$ is recommended
- c) leaf chains (measured in the part, which is in contact with the return pulley) $\Delta L_{max} = 3\% L_z$
- d) sport chains (motorcycles, bicycles) have their allowed specific elongation according to customer's usage.

Allowed chain elongation mentioned in per cent, relate to the over-all chain length.

The allowed maximum production tolerance of new chains from the basic dimension:

+ 0,15 % from over-all chain length - roller chain (according to CSN and DIN)

+ 0,10 % from over-all chain length - bush, high speed (only according to CSN).

How to measure the chain elongation

1. Disassemble the chain from the transmission and clean it. It is important to avoid the dirt and rest of the lubricant between the pin and the bush, these can distort the measuring.
Put the cleaned chain on a flat plate, stretch it, in order to take up the clearances between the parts, then measure the length with a measuring scale (outer holes pitch after connecting link). It is easier to measure 50 or 100 pitches. Subtract the basic length L_z from the measured length. The resulting value $\Delta L = L - L_z$ the chain elongation.

For quick determination of the extension use the following table $\Delta L_{max} =$ approximately 2 %.

Chain pitch		ΔL_{max} on 50 links [mm]	ΔL_{max} on 100 links [mm]
in inch	in mm		
	8,0	8,0	16,0
3/8"	9,525	9,5	19,0
1/2"	12,7	12,7	25,4
5/8"	15,875	16,0	32,0
3/4"	19,05	19,0	38,0
1"	25,4	25,5	51,0

2. Less exact method for the elongation evaluating is measuring directly on the transmission.
You must measure the chain the stretched section. The procedure of the calculation is the same like in point 1. For better exactness we measure the length L on arbitrary number of links (as many as possible).

EXPORT TERRITORIES OF ČZ CHAINS

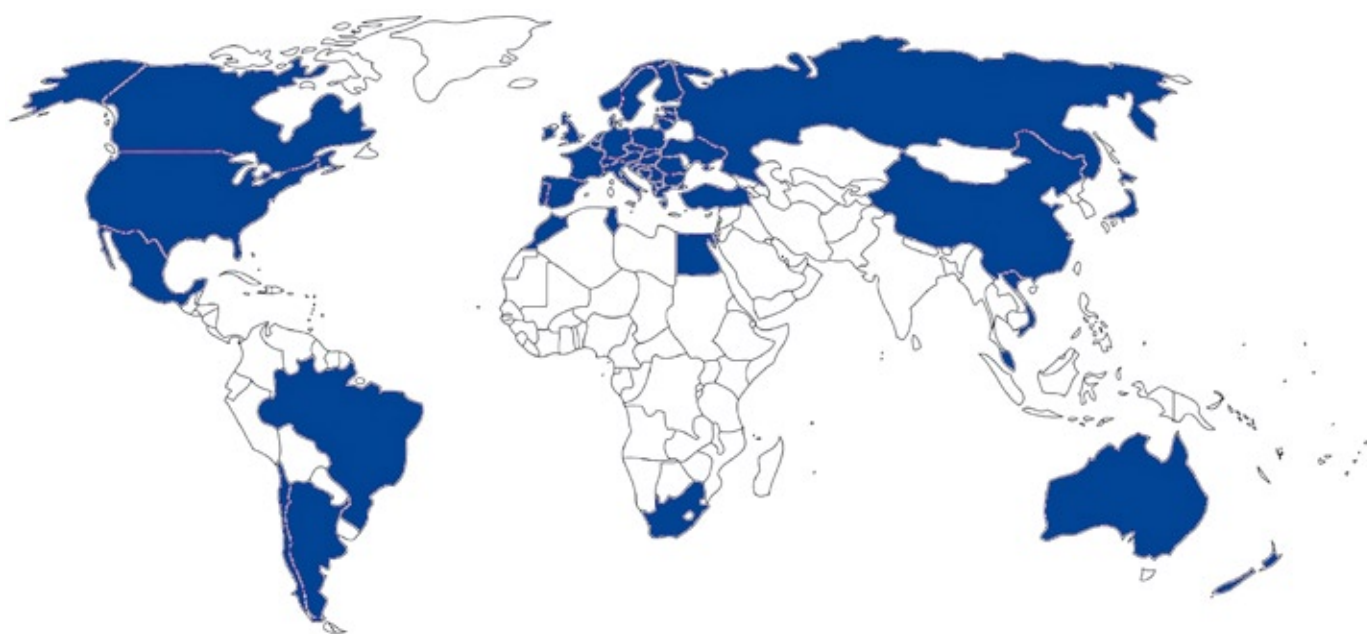

ČZ Chains

Quality with tradition

ENDURO



428 OR
520 ORM o-ring
520 RDO o-ring
520 ORMX X-ring, gold plate
520 ORH X-ring



MOTOCROSS



420
428
520 M
520 RD
520 MX gold plate
520 H



ROAD



520 SDZ X-ring
525 SDZ X-ring
525 BDZ X-ring, BMW GS
530 SDZ X-ring



KARTING



219 gold plate
219 OR o-ring, gold plate
428



ADVENTURE



520 ORMX X-ring
520 SDZ X-ring
525 SDZ X-ring

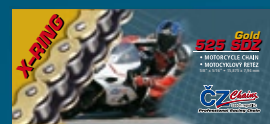

QUAD



520 ATV X-ring



ČZ Chains
czech republic
Professional Racing Chain

520 MX



SUPER

Gold 520 MX

- MOTORCYCLE CHAIN
- MOTOCYKLOVÝ RETĚZ

5/8" x 1/4" • 13,875 x 6,48 mm

ČZ Chains
czech republic
Professional Racing Chain



Original product of Czech Republic



Copyright ČZ Řetězy Ltd., Printed 03/2011

ČZ Řetězy s.r.o
Tovární 202
386 01 Strakonice
Czech Republic

tel.: +420 383 342 060
fax: +420 383 322 172
e-mail: prodej@czas.cz
www.czchains.com